

FORMWORK

Pressure Balance Control Valve Trim with Metal Lever Handle

Installation Guidelines

STYLE No. FMPB10

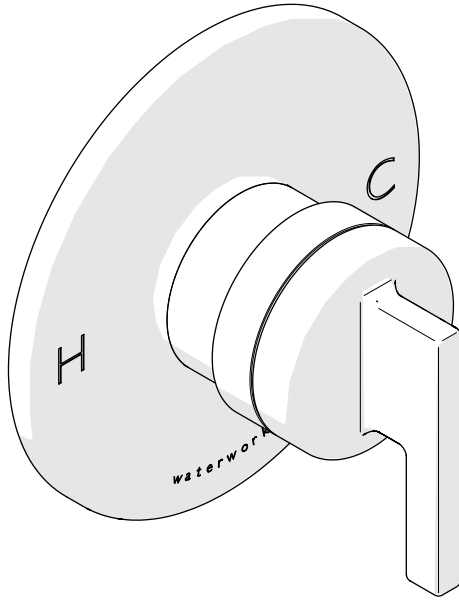

SPECIFICATIONS:

Rough-in Depth Minimum: 2-9/16" [65mm]
Rough-in Depth Minimum: 2-15/16" [74mm]
Fitting Hole Diameter: Ø3-1/2" [89mm]
Integrated Diverter: No

REQUIRED PLUMBING DETAILS:

Viaworks 1/2" Pressure Balance Valve
STYLE No. GUPB01

IMPORTANT:

- To ensure this product is installed properly, you must read and follow these guidelines.
- The owner/user of this product must keep this information for future reference.
- This product is intended to work with the Waterworks Viaworks Pressure Balance Valve (Style No. GUPB01). The VALVE controls on/off and mixes hot and cold water but can also be paired with a Waterworks Viaworks Two Way (Style No. GUDV2P) or Three Way (Style No. GUDV3P) Diverter Valve. All valves sold separately.
- The risk of scalding exists until the installer has properly calibrated/adjusted the temperature setting during final trim installation.
- This product must be installed by a professional licensed contractor and must be on-site prior to rough-in to allow the installer to visualize the installation.
- This product must be installed by a professional licensed contractor. Be sure your installation conforms to federal state, and local codes. In the State of Massachusetts, all installations must comply with the rules and regulations set forth within 248 CMR.

- This product must be on-site prior to rough-in. This allows the installer to visualize the installation and verify the center spread.
- Refer to the specification and assembly drawings attached. Product is sold partially assembled but shown fully disassembled for illustrative and service purposes only.
- Inspect this product to ensure you have all the parts required for proper installation. Use only a strap wrench or protected/smooth-jaw wrench on any finished surface.
- **DO NOT** use putty. Putty contains oil and can cause permanent discoloration on certain materials such as marble, granite and any porous surface. T

VALVE OPERATION:

1. Turn on the hot and cold supplies then remove the TILE GUARD and BONNET COVER as shown in Figure - 01.
- **NOTE:** The VALVE will not operate unless both hot and cold supplies are turned on. If the VALVE has remained unused for an extended period of time (over 3 months) water to the VALVE should have been shut off (via service stops or system control valve) and the VALVE should have been opened to allow the water in the VALVE to evaporate. This is to keep the piston in the VALVE SPINDLE from sticking, due to stagnant or hard water, once the VALVE is in use again. If the piston does stick, soak the VALVE SPINDLE in household vinegar. Refer to the installation guidelines for the VALVE which contains maintenance instructions, Complete parts breakdown and related information.

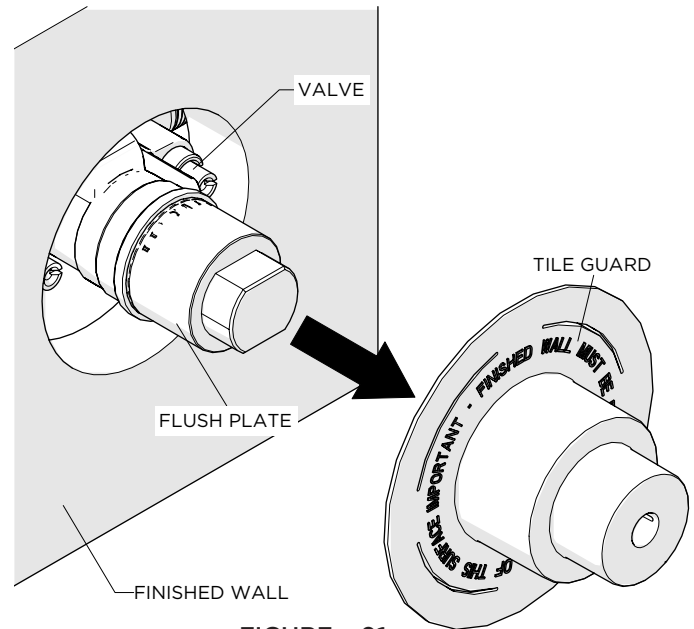

FIGURE - 01

2. With the VALVE off, place the HANDLE on the VALVE STEM in the 6 o'clock position. Turn the HANDLE counterclockwise through the cold, warm and stopping at the hot position. If additional rotational friction is required to maintain the handle position, tighten the PACKING NUT as shown in Figure - 02.

NOTE: The HANDLE is for controlling temperature only, not volume.

These guidelines have been prepared for the professional contractor to aid in the installation of:
FORMWORK PRESSURE BALANCE CONTROL VALVE TRIM WITH METAL LEVER HANDLE (STYLE No. FMPB10)
All dimensions are based on original specification and are subject to change and variation.
Please consult your Design Associate for current specifications.

WATERWORKS

FORMWORK

Pressure Balance Control Valve Trim with Metal Lever Handle

Installation Guidelines

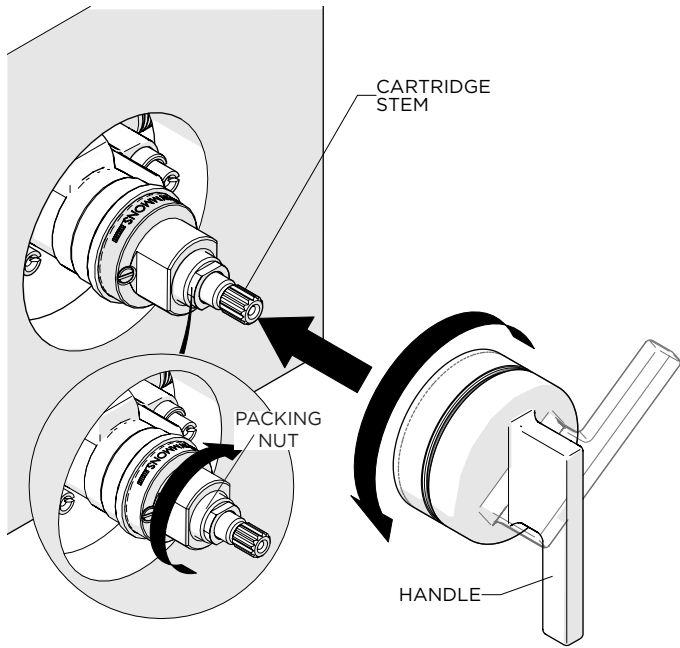

FIGURE - 02

3. Allow the VALVE to run in the warm position for a few minutes to completely flush the system. If the system is significantly dirty, remove the VALVE SPINDLE to ensure proper flushing as shown in Figure - 03.
- Refer to the installation guidelines for the valve which contains a complete parts breakdown and related information.

4. Turn the VALVE STEM to open the VALVE to the maximum desired temperature. Verify the temperature with a the mometer and turn the HOT LIMIT SAFETY STOP SCREW clockwise until it seats as shown in Figure - 04.
- **WARNING: FAILURE TO ADJUST THE HOT LIMIT SAFETY STOP SCREW PROPERLY MAY RESULT IN SERIOUS SCALDING**

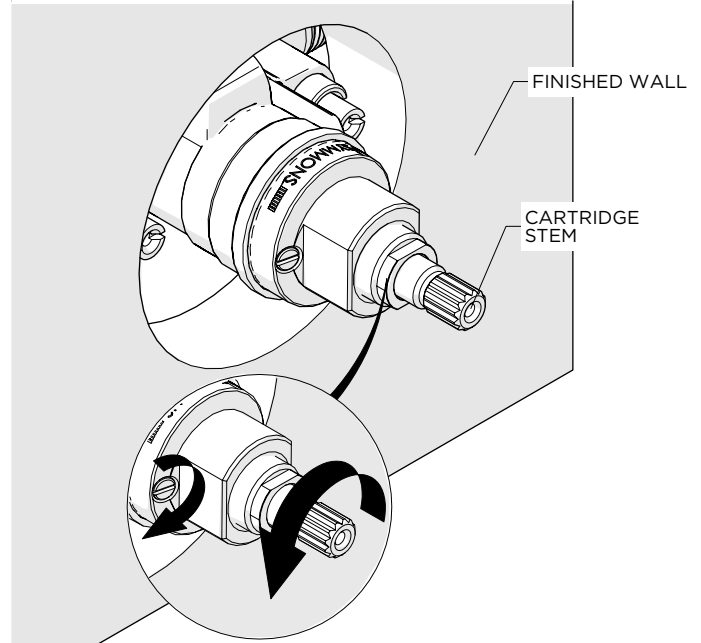

FIGURE - 04

TRIM INSTALLATION:

5. Thread the GLAND COVER onto the PACKING NUT as shown in Figure - 05.

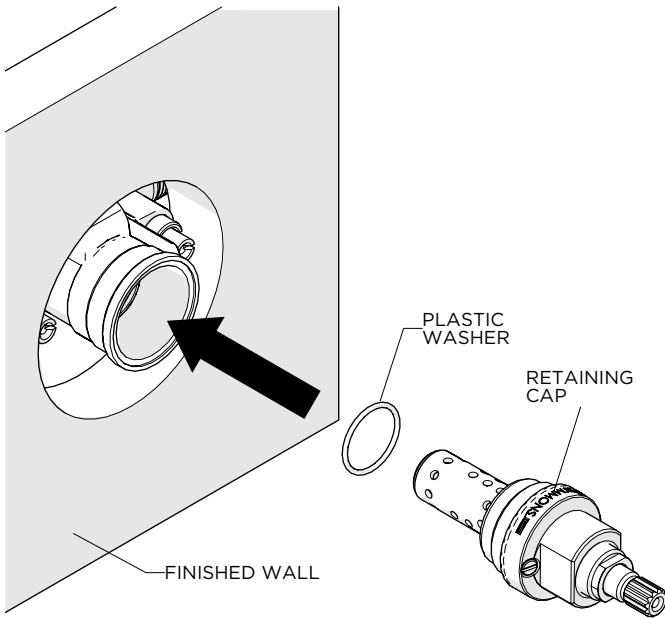

FIGURE - 03

HOT LIMIT SAFETY STOP CALIBRATION:

- **IMPORTANT:** The VALVE is equipped with a HOT LIMIT SAFETY STOP SCREW to limit the VALVE SPINDLE from being turned to excessive hot water discharge temperature.

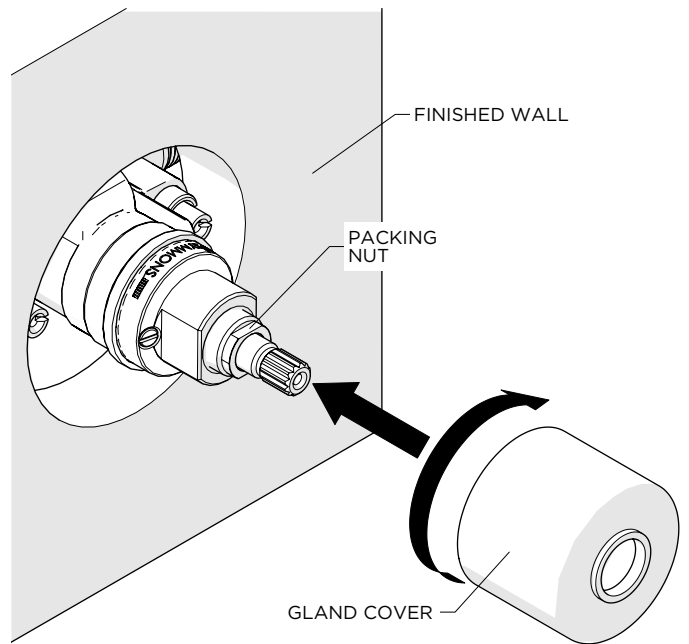

FIGURE - 05

These guidelines have been prepared for the professional contractor to aid in the installation of: FORMWORK PRESSURE BALANCE CONTROL VALVE TRIM WITH METAL LEVER HANDLE (STYLE No. FMPB10)
All dimensions are based on original specification and are subject to change and variation.
Please consult your Design Associate for current specifications.

FORMWORK

Pressure Balance Control Valve Trim with Metal Lever Handle

Installation Guidelines

6. Hold the TRIM PLATE against the finished wall then thread the RETAINING COLLAR onto the GLAND COVER as shown in Figure - 06. Securely tighten the RETAINING COLLAR to hold the TRIM PLATE against the finished wall.

NOTE: A GASKET for the TRIM PLATE is provided. If desired, a bead of caulk or a clear silicone may be applied where the TRIM PLATE contacts the finished wall. **DO NOT** use putty.*

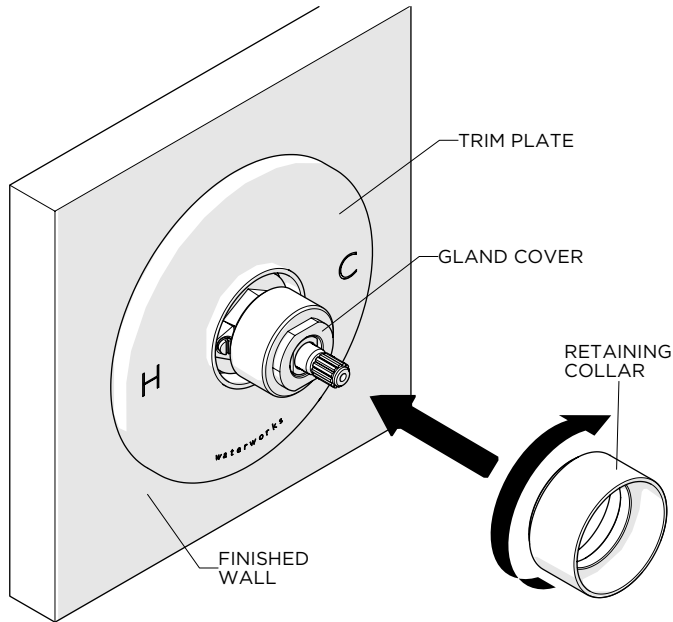
**FIGURE - 06**

7. With the VALVE turned off, place the HANDLE on the VALVE STEM in the 6 o'clock position then tighten the SET SCREW to secure the HANDLE as shown in Figure - 07.

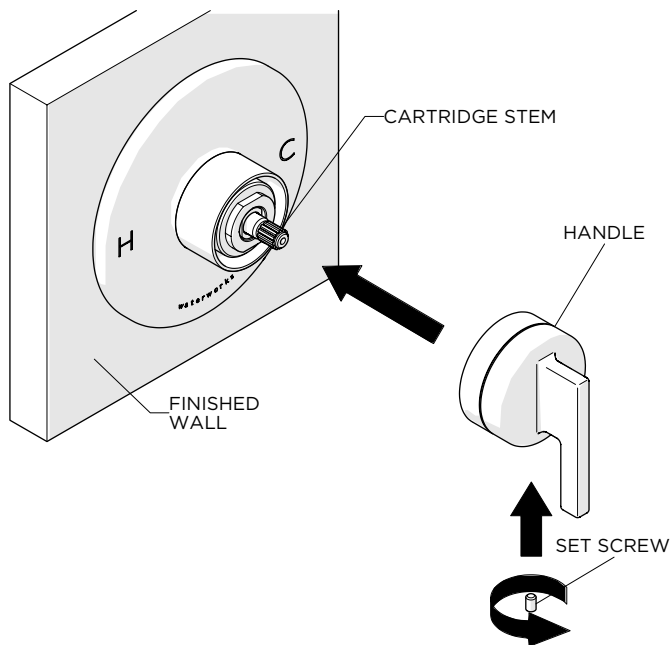
**FIGURE - 07**

8. Turn the HANDLE until it stops and using a thermometer, verify that the temperature is the same as the temperature set in Step 4. If the temperature is not the same repeat the calibration process.

➤ If further assistance is required, please contact Product Support at 1-800-927-2120 Monday through Friday, 8 am - 6 pm EST.

➤ See the service part document for parts ordering, available on WATERWORKS.COM.

These guidelines have been prepared for the professional contractor to aid in the installation of:
FORMWORK PRESSURE BALANCE CONTROL VALVE TRIM WITH METAL LEVER HANDLE (STYLE No. FMPB10)
 All dimensions are based on original specification and are subject to change and variation.
 Please consult your Design Associate for current specifications.

WATERWORKS