

STYLE No. PTPB59

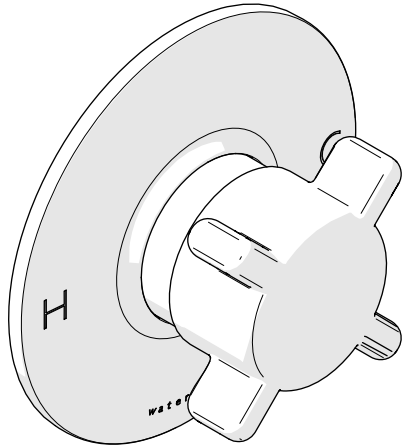

SPECIFICATIONS:

Control Valve Rough-in Depth Maximum: 2-3/8" [60mm]
Control Valve Rough-in Depth Minimum: 1-7/8" [48mm]
Fitting Hole Diameter: Ø3-1/2" [89mm]
Integrated Diverter: No

REQUIRED PLUMBING DETAILS:

Universal Pressure Balance Valve
STYLE No. GUPB81 (SOLD SEPARATELY)

IMPORTANT:

- To ensure this product is installed properly, you must read and follow these guidelines.
- The owner/user of this product must keep this information for future reference.
- This product is intended to work with the Waterworks Universal Pressure Balance Valve (GUPB81).
- The risk of scalding exists until the installer has properly calibrated/adjusted the temperature setting during final trim installation.
- This product must be installed by a professional licensed contractor.
- Be sure your installation conforms to federal state, and local codes. In the State of Massachusetts, all installations must comply with the rules and regulations set forth within 248 CMR.
- This product must be onsite prior to rough-in, this allows the installer to visualize the installation.
- Inspect this product to ensure you have all the parts required for proper installation.

- Use only a strap wrench or protected/smooth-jaw wrench on any finished surface.
- The use of certain plumber's putty may stain stone or tile surfaces.

ROUGH-IN:

1. Valve rough-in depth is measure from the centerline of the inlets to the surface of the finished wall and varies depending on the trim being used. See Figure - 01.
2. For this product, ensure the valve is roughed-in between 1-7/8" and 2-3/8" as shown in Figure - 01.

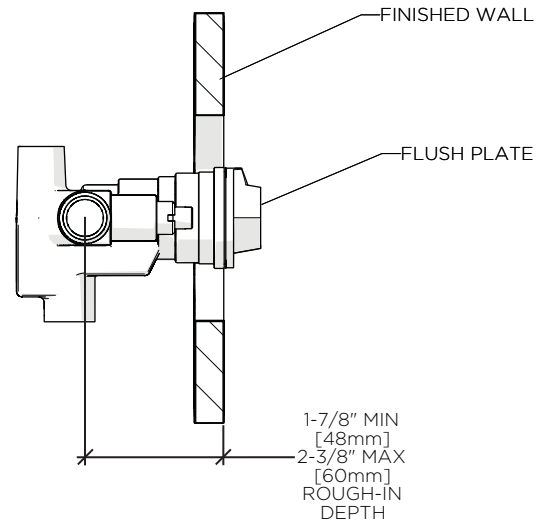

FIGURE - 01

FLUSH OUT THE SYSTEM:

3. Ensure that the supply lines are flushed prior to final trim installation. The Universal Pressure Balance Valve (sold separately) includes a pre-installed FLUSH PLATE.
4. Refer to the Installation Guidelines of the Universal Pressure Balance Valve for further information on how to properly flush the supply lines.

CARTRIDGE INSTALLATION:

5. After the supply lines have been flushed turn off the water supply, close the SERVICE STOPS and remove the FLUSH PLATE. See Figure - 02.
- To open and close the SERVICE STOPS remove the SERVICE STOP COVER SCREWS using a slotted screw driver and insert a 3/16" hex key into the SERVICE STOP.

These guidelines have been prepared for the professional contractor to aid in the installation of:
.25 PRESSURE BALANCE CONTROL VALVE TRIM WITH METAL CROSS HANDLE (STYLE No. PTPB59)
All dimensions are based on original specification and are subject to change and variation.
Please consult your Design Associate for current specifications.

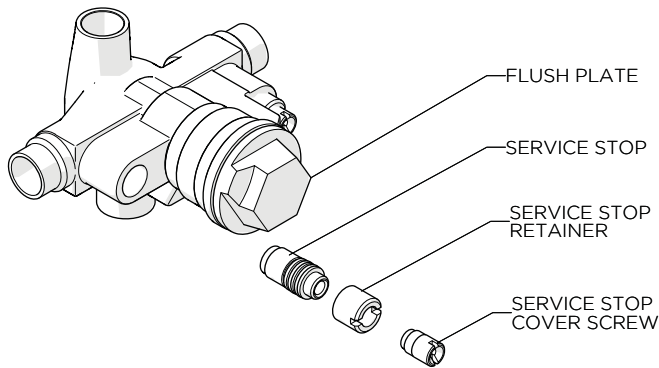

FIGURE - 02

6. Install the CARTRIDGE, RETAINING CAP, PACKING and PACKING NUT as an assembly making sure to include the CAP GASKET. See Figure - 03.

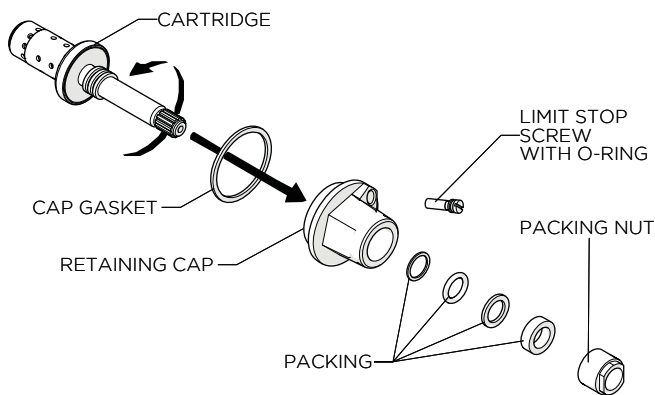

FIGURE - 03

- **IMPORTANT:** To avoid distortion of the cartridge stem, back out the LIMIT STOP SCREW until the O-RING is fully exposed. Turn the CARTRIDGE counterclockwise until it stops. Make sure that the CARTRIDGE is drawn close to the RETAINING CAP before screwing the CAP into the valve. Leave the PACKING and PACKING NUT in place to avoid distortion.
7. Open both hot and cold SERVICE STOPS and check the valve and all connections for leaks then re-install the SERVICE STOP COVER SCREWS. See Figure - 02.
- The valve will not operate unless both hot and cold supplies are turned on.
8. Tighten the PACKING NUT for the desired frictional resistance when turning the HANDLE. See Figure - 03.

VALVE CALIBRATION:

- The HANDLE is for controlling the temperature only, not volume.
9. Remove the SET SCREW using a 3mm hex key from the HANDLE then slide it onto the CARTRIDGE STEM.

10. Slowly turn the CARTRIDGE STEM to adjust the temperature to the maximum desired bathing temperature, verified with a thermometer, and then turn the LIMIT STOP SCREW clockwise until it seats.

- **NOTE:** The maximum turn of the valve is approximately one revolution.
- **IMPORTANT:** Failure to adjust the LIMIT STOP SCREW properly increases the chances for serious injury.
- **WARNING:** The valve may not provide protection against scalding if there is a failure of other temperature limiting devices elsewhere in the plumbing system.

11. Turn the valve off then back on, to verify that the LIMIT STOP SCREW functions properly and that the temperature does not exceed the temperature that was set in the previous step. If it is not the correct temperature, repeat the calibration procedures.

12. Turn the valve off.

TRIM INSTALLATION:

13. Remove the HANDLE after setting the temperature.
14. Hand-tighten the TRIM CONNECTOR completely onto the valve. The CONNECTOR **must** be tightened to prevent damage to the HANDLE. See Figure - 04.

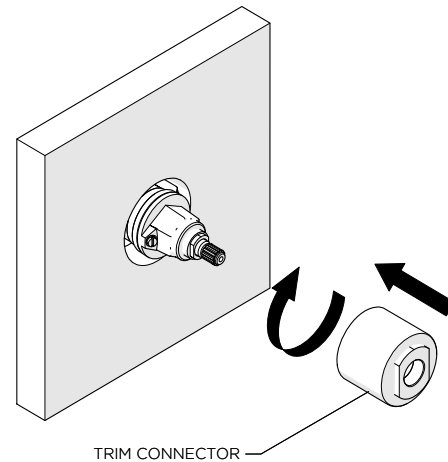

FIGURE - 04

15. Slide the TRIM PLATE over the TRIM CONNECTOR and hold the PLATE against the finished wall then thread the TRIM ADAPTER onto the TRIM CONNECTOR to secure the PLATE against the finished wall. See Figure - 05.

- **NOTE:** A GASKET for the TRIM PLATE is provided. If desired, a bead of caulk or a clear silicone may be applied where the plate contacts the finished wall. The use of certain plumber's putty may stain stone or tile surfaces.

These guidelines have been prepared for the professional contractor to aid in the installation of:
.25 PRESSURE BALANCE CONTROL VALVE TRIM WITH METAL CROSS HANDLE (STYLE No. PTPB59)
 All dimensions are based on original specification and are subject to change and variation.
 Please consult your Design Associate for current specifications.

W A T E R W O R K S

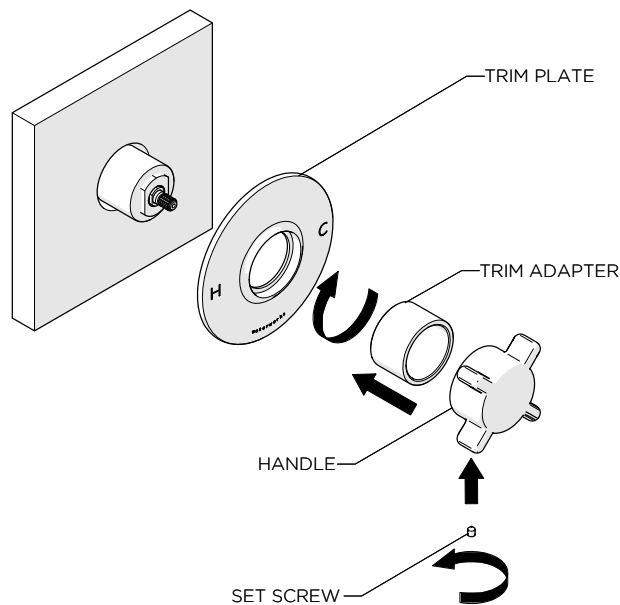
**FIGURE - 05**

16. Position the HANDLE with the set screw hole at 6:00 then slide the HANDLE onto the CARTRIDGE STEM. Secure the HANDLE to the STEM by tightening the SET SCREW with a 3mm hex key. See Figure - 05.
 17. Open the valve and confirm the temperature setting, adjust as required.
- For valve service & troubleshooting refer to the Installation Guidelines of the Universal Pressure Balance Valve for further information.
 - If further assistance is required, please contact Product Support at 1-800-927-2120 Monday through Friday, 8am - 7pm EST.
 - Refer to the separate Service Parts Documents for available replacement parts.

These guidelines have been prepared for the professional contractor to aid in the installation of:
.25 PRESSURE BALANCE CONTROL VALVE TRIM WITH METAL CROSS HANDLE (STYLE No. PTPB59)
 All dimensions are based on original specification and are subject to change and variation.
 Please consult your Design Associate for current specifications.

W A T E R W O R K S