

HENRY

HNXT70

Henry Exposed Floor Mounted Tub Filler with Handshower and Metal Lever Handles



SHOWN IN HENRY EXPOSED FLOOR MOUNTED TUB FILLER WITH HANDSHOWER AND METAL LEVER HANDLES| HNXT70

TECHNICAL DETAILS

ADA Compliance: Yes
 Adjustable versus Fixed Spray: Fixed Spray
 Diameter of Head: 1 7/8"
 Escutcheon Primary Material: Brass
 Fittings Hole Diameter: 1 1/8"
 Flow Restriction Options: 2.5, 2.0, 1.75, 1.5, 0.92
 Handle Spread Maximum: 8"
 Handle Spread Minimum: 8"
 Handle Turn Angle: Quarter Turn
 Handshower / Spray Hose Length: 59"
 Depth / Width: 10 13/16"
 Height: 41 1/16"
 Inlet Connection Size: 3/4"
 Inlet Connection Type: Copper Sweat
 Inlet Supply Spread Maximum: 8"
 Inlet Supply Spread Minimum: 8"
 Installation Type: Freestanding
 Integrated Diverter: N
 Integrated Spray: N
 Number of Handles: Two
 Number of Holes: Two Hole
 Primary Material: Brass
 Suggested Application: Bath
 Valve Material: Ceramic
 Water Pressure Maximum: 85.0 psi
 Water Pressure Minimum: 20.0 psi
 Water Pressure Recommended: 45.0 psi

INSPIRATION

Influenced by the connection of industry and art Henry easily transitions between modern, traditional, utilitarian and classic settings.

PRODUCT FEATURES

The manufacturing process encompasses casting, turning, forging, hand-fitting and hand polishing. Brass material is used for components.

Stocked in 2.5gpm (9.5 L/min) and 1.75gpm (6.6 L/min) for Handshower. State of California requires 1.75gpm (6.6 L/min) to comply with their water conservation requirements. Other flow options are available to order, contact your sales associate or call 1 (800) 899-6757 for details



HENRY

HNXT70

Henry Exposed Floor Mounted Tub Filler with Handshower and Metal Lever Handles

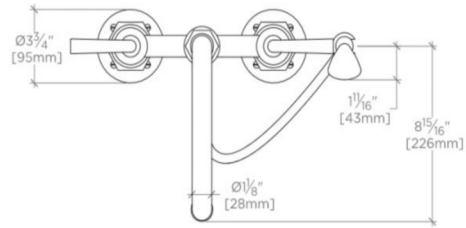

TOP VIEW

SCALE: 1/2"=1'-0"

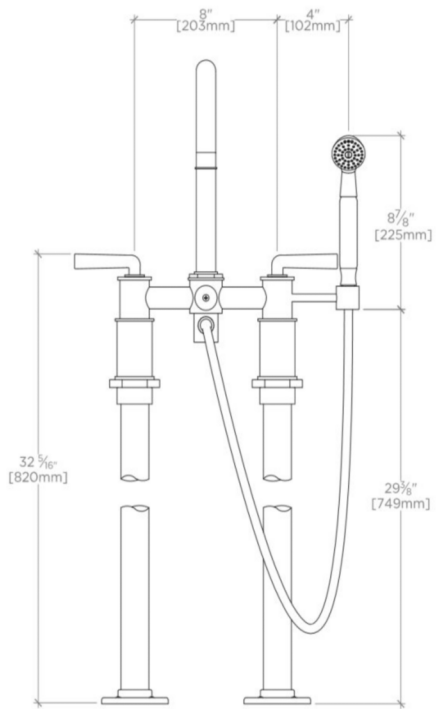

FRONT VIEW

SCALE: 1/2"=1'-0"

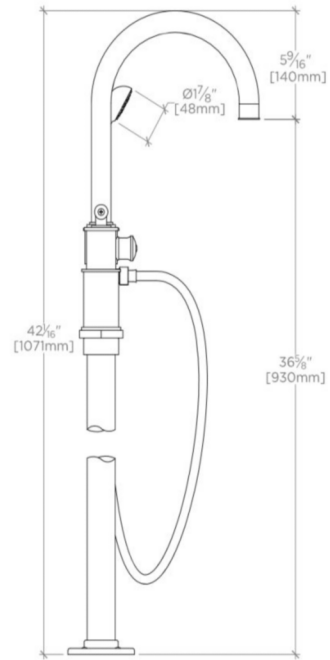

SIDE VIEW

SCALE: 1/2"=1'-0"