

INSTALLATION GUIDELINES

AIR GAP

UNIVERSAL AIR GAP

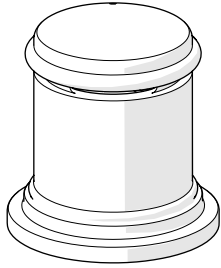

STYLES

UNAG01	UNAG02	UNAG03
--------	--------	--------

IMPORTANT:

- To ensure this product is installed properly, you must read and follow these guidelines.
- The owner/user of this AIR GAP must keep this information for future reference.
- This AIR GAP must be installed by a professional licensed contractor.
- This AIR GAP is **sold partially** assembled but shown fully disassembled for illustrative and service purposes only. Inspect the AIR GAP to ensure you have all the parts required for proper installation.
- Be sure your installation conforms to all federal, state, and local codes. In the State of Massachusetts, all installations must comply with the rules and regulations set forth within 248 CMR.
- Use only a strap wrench or protected/smooth-jaw wrench on any finished surface.
- The use of certain plumber's putty may stain stone or tile surfaces.- If further assistance is required, please contact Product Support at 1-800-927-2120 Monday through Friday, 8am - 6pm EST.

TECHNICAL DETAILS:

FITTING HOLE DIAMETER	Ø1-1/4" [32mm]
DECK THICKNESS	1-5/8" [42mm] MAX

WATERWORKS

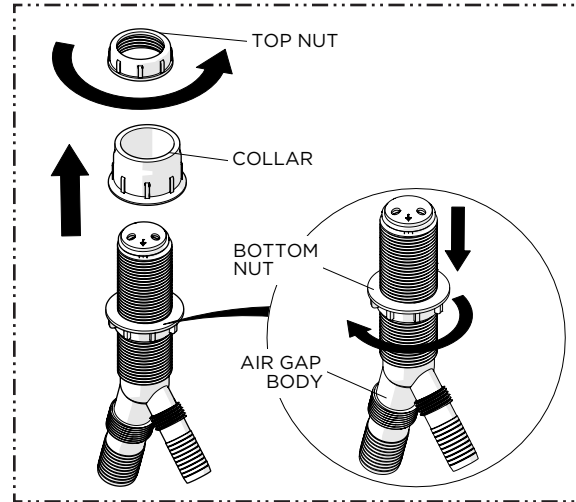

1. Unthread the TOP NUT and take off the COLLAR, then fully thread the BOTTOM NUT down the AIR GAP BODY.

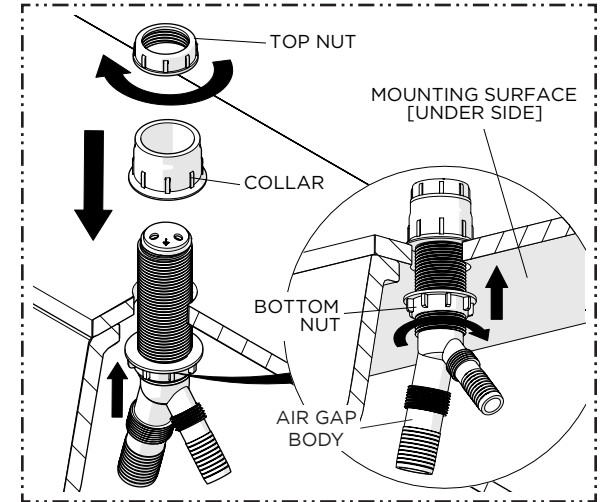

2. Insert the AIR GAP BODY up through the MOUNTING HOLE from underneath, reinstall the COLLAR from the top, then thread the TOP NUT back onto the AIR GAP BODY until snug, let it rest on the MOUNTING SURFACE and securely tighten the BOTTOM NUT against the underside of the MOUNTING SURFACE.

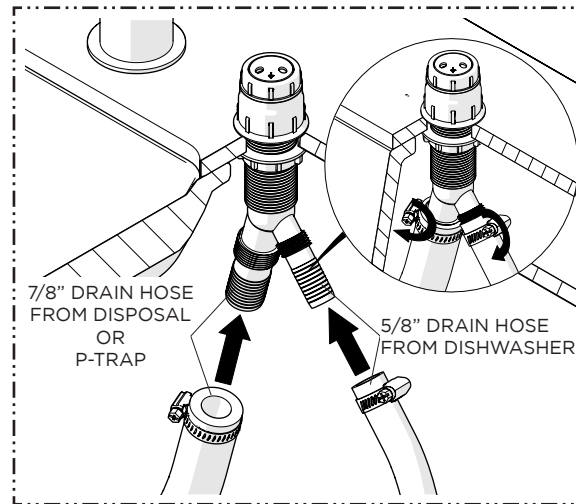

3. Connect the 5/8" HOSE from the DISHWASHER and the 7/8" HOSE from the DISPOSAL OR P-TRAP to the AIR GAP BODY and if necessary using HOSE CLAMPS to secure the connections tightly.

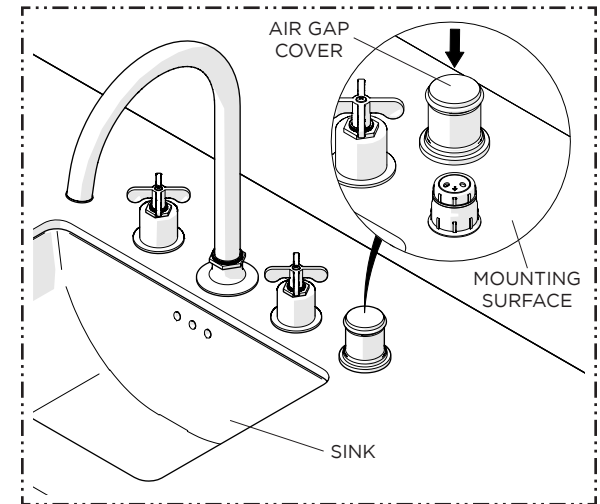

4. Push-fit the AIR GAP COVER onto the top of the AIR GAP KIT, ensuring the opening of the AIR GAP COVER is facing toward the SINK.