

INSTALLATION GUIDELINES

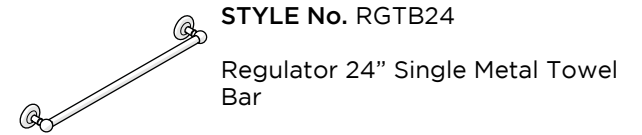

STYLE No. RGTB24

Regulator 24\"/>

IMPORTANT:

- To ensure this product is installed properly, you must read and follow these guidelines.
- The owner/user of this product must keep this information for further reference.
- This product must be installed by a professional licensed contractor.
- Inspect this product to ensure you have all the parts required for proper installation.
- If further assistance is required, please contact Product Support at 1-800-927-2120 Monday through Friday, 8am - 6pm EST.
- Refer to the separate Service Parts Documents for available replacement parts.

TECHNICAL DETAILS:

DETAIL	SPECIFICATION
PRIMARY MATERIAL	BRASS
TUBE DIAMETER	7/8" [22mm]

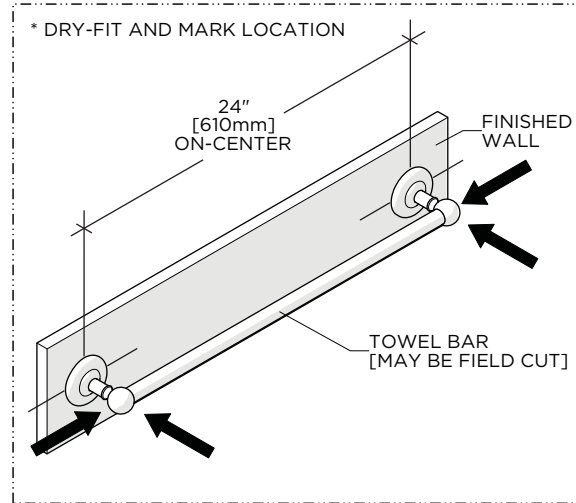

1. Dry-fit the product to the finished wall and mark the ideal location making sure to hold the product level.

NOTE: Verify the 24" [610mm] on-center spread.

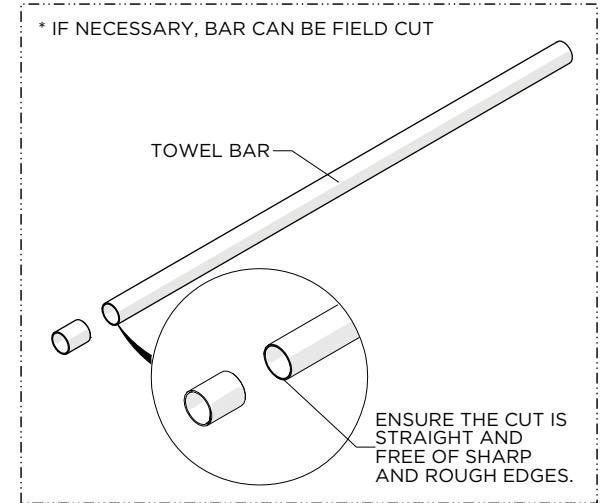

OPTIONAL: If necessary, the BAR may be cut. Ensure the cut is straight and free of sharp and rough edges.

2. Cut the BAR to the desired length then repeat STEP 1, marking the new on-center spread.

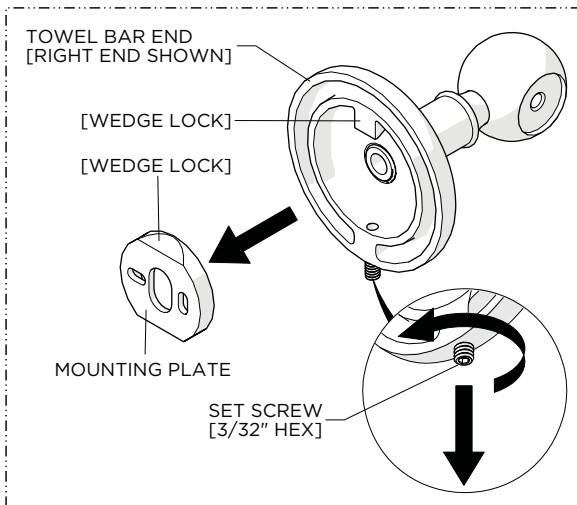

3. Loosen, but do **NOT** remove, the SET SCREW on the bottom of each TOWEL BAR END using a 3/32" HEX KEY and remove the MOUNTING PLATES.

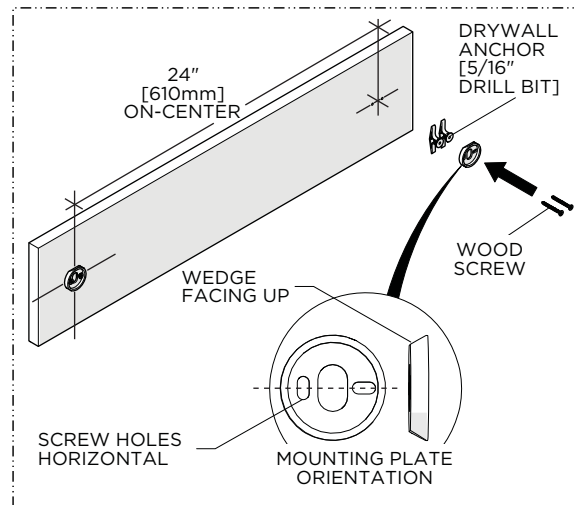

4. Using the previous marks as a reference, install the MOUNTING PLATES using the SCREWS and ANCHORS provided.

CAUTION: Ensure the MOUNTING PLATES are in the correct orientation, level, and at the 24" [610mm] on-center spread.

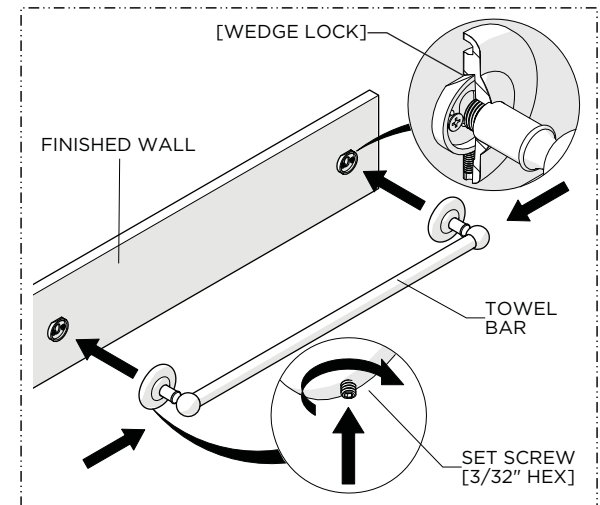

5. Holding the ENDS and BAR together, place both ENDS over the MOUNTING PLATES and securely tighten the SET SCREWS.

NOTE: The SET SCREWS should face towards the bottom.