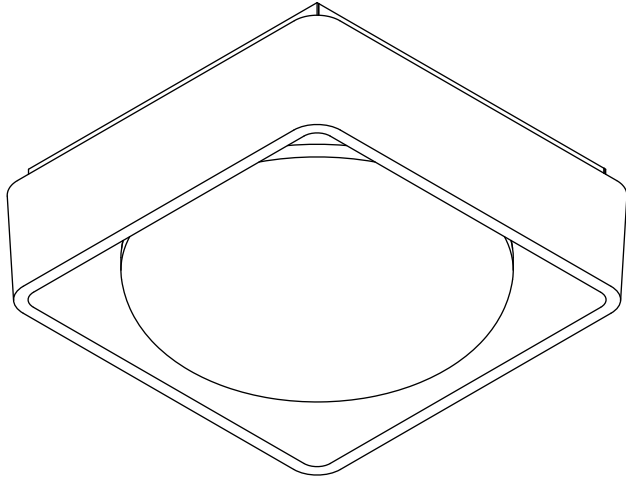

Style No. ENLT03 [EN03LT]

Ceiling Flush Mount

**SPECIFICATIONS:**

Junction Box Orientation: Any

Junction Box: Standard octagonal box

Junction Box Size: Standard octagonal box 3-1/2"

This luminaire must be mounted or supported independently of an outlet box

Orientation: Ceiling

Lens Material: Glass or Alabaster

Voltage: 120 [240] Vac

Require Electrical Feeds:

Black "Hot" wire; White "Neutral" wire; Green or Bare "Ground" wire

[Brown "Line" wire; Blue "Neutral" wire; Green/Yellow Striped or Bare "Earth" wire]

IMPORTANT:

- **WARNING:** The power supply must be turned off prior to installation. Turn off the main electrical supply to the junction box from the fuse box/circuit breaker. Turning power off at the switch is not sufficient.
- To ensure this product is installed properly, you must read and follow these guidelines.
- The owner/user of this product must keep this information for future reference.
- ENLT03 is U.L. certified and suitable for damp or dry locations. The U.L. listing mark can be found on the inside of the cover plate.
- [EN03LT] is CE rated. Proof of CE compliance will be provided upon request
- Be sure your installation conforms to all national installation and safety regulations for the installation.
- This product must be installed by a professional licensed electrical contractor.
- Refer to the specification and assembly drawings attached. Product is sold partially assembled but shown fully disassembled for illustrative and service purpose only.

These guidelines have been prepared for the professional contractor to aid in the installation of:
ENZO WALL/CEILING MOUNTED SCONCE (STYLE# ENLT03 [EN03LT])
 All dimensions are based on original specification and are subject to change and variation.
 Please consult your Design Associate for current specifications.

WATERWORKS

ENLT03 [EN03LT] INSTALLATION:

- REQUIRED: Install a 3-1/2" Octagon Box electrical junction box at the desired height.
 - REQUIRED: This luminaire must be mounted or supported independently of an outlet box.
 - See Figure - 01 for Steps 1-4.
1. Remove the CONNECTION BOX BACK PART from the CONNECTION BOX FRONT PART by loosening 4 SET SCREWS using HEX WRENCH provided.

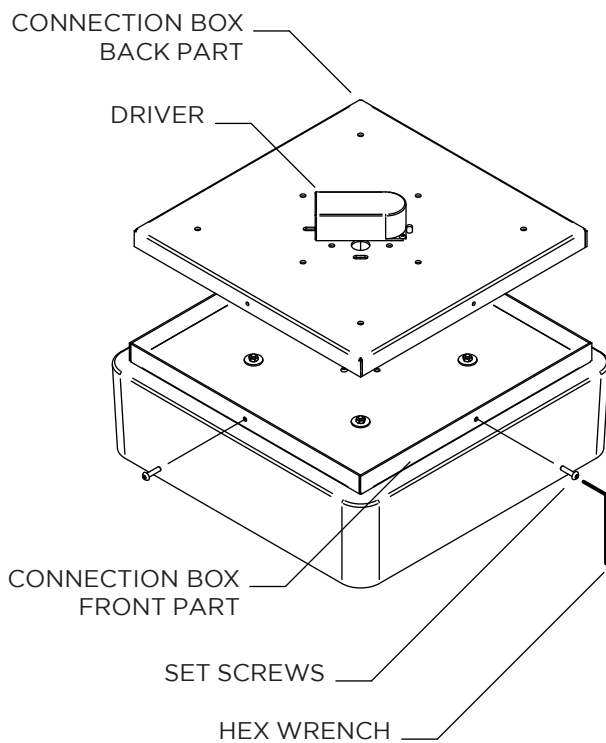

FIGURE - 01

- See Figure - 02 for Steps 2-5.
2. Install the CONNECTION BOX BACK PART onto the JUNCTION BOX, by first connecting the copper wire from the plate to the GROUND WIRE from the junction box using a wire nut.
 3. Next, connect the neutral wire from the driver to the neutral wire from the junction box using a wire nut. Tightly wrap the connection with electrical tape beginning 1" [25mm] below the wire nut to ensure the tape seals the end of the nut. Make sure that there are no exposed wires that could cause a short circuit.
 4. Repeat previous step with the hot [line] wires from the DRIVER and JUNCTION BOX. Make sure all connected wires are pushed into the junction box.
 5. Attach the CONNECTION BOX BACK PART to the ceiling using the FIXING HOLES making sure to keep proper alignment of the plate and the LOW VOLTAGE PLUG outside the junction box. Fixing screws are not included in the package. Use the screws suitable for your wall for a 3/16" [5mm] diameter hole on the plate.

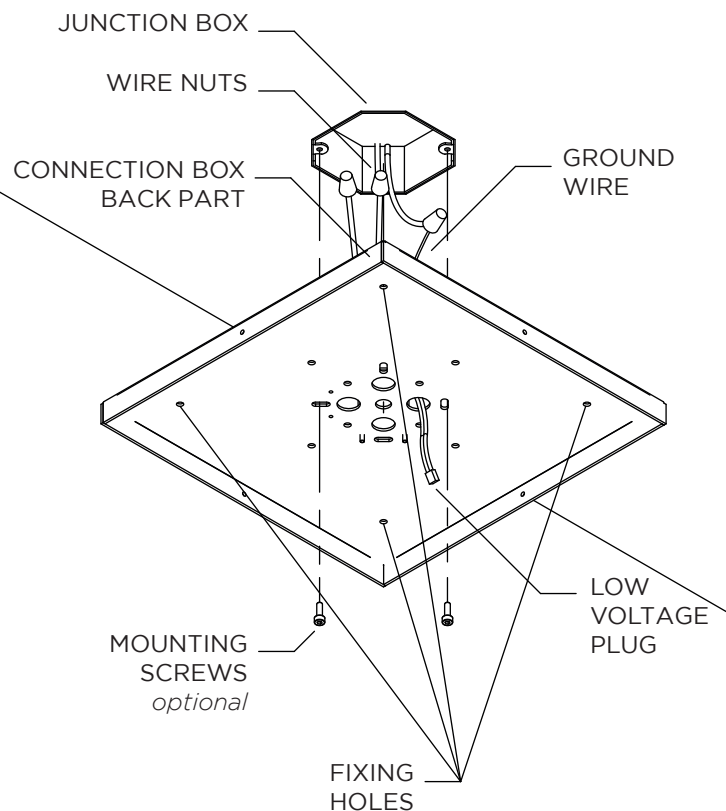

FIGURE - 02

These guidelines have been prepared for the professional contractor to aid in the installation of:
ENZO WALL/CEILING MOUNTED SCONCE (STYLE# ENLT03 [EN03LT])
 All dimensions are based on original specification and are subject to change and variation.
 Please consult your Design Associate for current specifications.

WATERWORKS

- See Figure - 03 for Steps 6-9.
- 6. Connect the PLUG CONNECTOR from the CONNECTION BOX FRONT PART into the PLUG CONNECTOR from the CONNECTION BOX BACK PART.
- 7. Mount CONNECTION BOX FRONT PART onto CONNECTION BOX BACK PART making sure all wires are pushed into the CONNECTION BOX.
- 8. Using the HEX WRENCH provided, tighten the 4 SET SCREWS until CONNECTION BOX FRONT PART is secure.
- 9. Restore power to branch circuit.

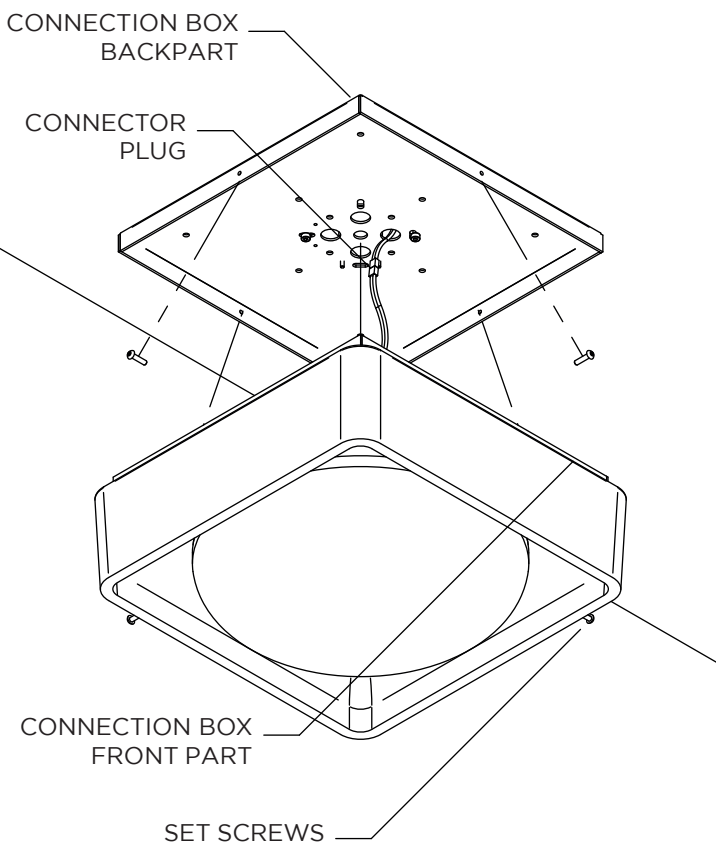

FIGURE - 03

These guidelines have been prepared for the professional contractor to aid in the installation of:
ENZO WALL/CEILING MOUNTED SCONCE (STYLE# ENLT03 (EN03LT1))
 All dimensions are based on original specification and are subject to change and variation.
 Please consult your Design Associate for current specifications.

WATERWORKS