

INSTALLATION GUIDELINES

THERMOSTATIC AND VOLUME CONTROL TRIMS

BOND INTEGRATED THERMOSTATIC AND VOLUME CONTROL TRIM

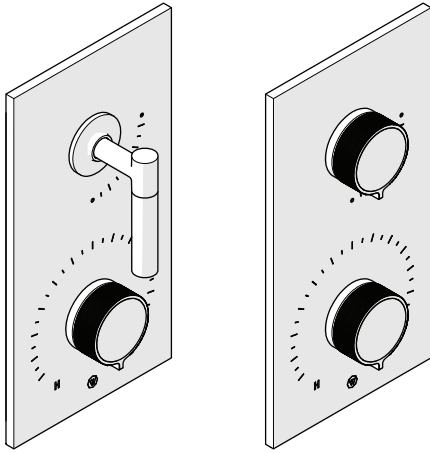

STYLES		
BTH320	BTH32A	BTH32B [SHOWN]
BTH32C	BTH32D	BTH32E
BTH32S	BTH330	BTH33S
BTH34A [SHOWN]	BTH34B	BTH34D
BTH35C		

REQUIRED PLUMBING DETAILS:

- ViaWorks 1/2" Thermostatic Valve with Integrated Volume Control Valve
STYLE No. GUTH71

IMPORTANT:

- To ensure this product is installed properly, you must read and follow these guidelines.
- The owner/user of this product must keep this information for future reference.
- This product must be installed by a professional licensed contractor and must be onsite prior to rough-in. This allows the installer to visualize the installation.
- **ALL VALVES AND TRIMS SOLD SEPARATELY.**

- This product is intended to work with the VIAWORKS 1/2" THERMOSTATIC VALVE WITH INTEGRATED VOLUME CONTROL VALVE (Style No. **GUTH71**). Refer to the Installation Guidelines provided with the VALVE for complete rough-in installation details and related information.
- Be sure your installation conforms to all federal, state, and local codes. In the State of Massachusetts, all installations must comply with the rules and regulations set forth within 248 CMR.
- **WARNING:** The **GUTH71** features anti-scald protection. The risk of scalding exists until the installer has properly calibrated/adjusted the temperature setting during final TRIM installation.
- This product is sold partially assembled but shown fully disassembled for illustrative and service purposes only.
- Inspect this product to ensure you have all the parts required for proper installation.
- Use only a strap wrench or protected/smooth-jaw wrench on any finished surface.
- The use of certain plumber's putty may stain stone or tile surfaces.
- If this product will remain unused for an extended period of time (over 3 months), then the water to the THERMOSTATIC VALVE should be shut off (via service stops or system control valve) and the INTEGRATED VOLUME CONTROL VALVE should be opened to allow the water in the THERMOSTATIC VALVE to evaporate. This is to keep the THERMOSTATIC CARTRIDGE from being exposed to stagnant or hard water, which can cause the VALVE to malfunction.
- If further assistance is required, please contact Product Support at 1-800-927-2120 Monday through Friday, 8am - 6pm EST.
- Refer to the separate Service Parts Documents for available replacement parts.

INSTALLATION GUIDELINES

THERMOSTATIC AND VOLUME CONTROL TRIMS

HANDLE OPERATION AND VALVE FUNCTION:

- The **THERMOSTATIC VALVE** only mixes hot and cold water. It does not have volume or shut-off capabilities. Mixed water flows out at a fixed volume to the **INTEGRATED VOLUME CONTROL VALVE** which has 2 positions.
 - 1 ON position that can direct water flow to a **MAXIMUM** of 1 device.
 - 1 OFF position.
 - The **INTEGRATED VOLUME CONTROL VALVE** incorporates tactile feedback at each position.

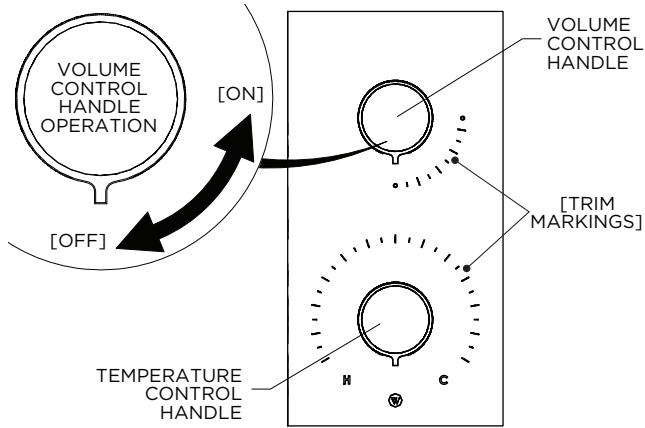

ROUGH-IN AND VALVE PREPARATION:

- The **THERMOSTATIC VALVE** is provided with a pre-installed **FLUSH PLATE**. The **THERMOSTATIC CARTRIDGE**, **RETAINING NUT**, and **THREADED TUBE** are packaged separately and provided with the **VALVE**.
- **IMPORTANT:** Make sure the supply lines are flushed prior to final **TRIM** installation using the **FLUSH PLATE** provided. Refer to the Installation Guidelines provided with the **VALVE** for further information.
- **CAUTION:** The rough-in depth is measured from the centerline of the inlets to the surface of the finished wall. If the **VALVE** is roughed-in too shallow, the **TRIM** cannot be installed correctly.
- Remove and discard the **TILE GUARDS** only when the finished wall surface (**TILE** or **SLAB**) is completed and **TRIMS** are ready for installation.

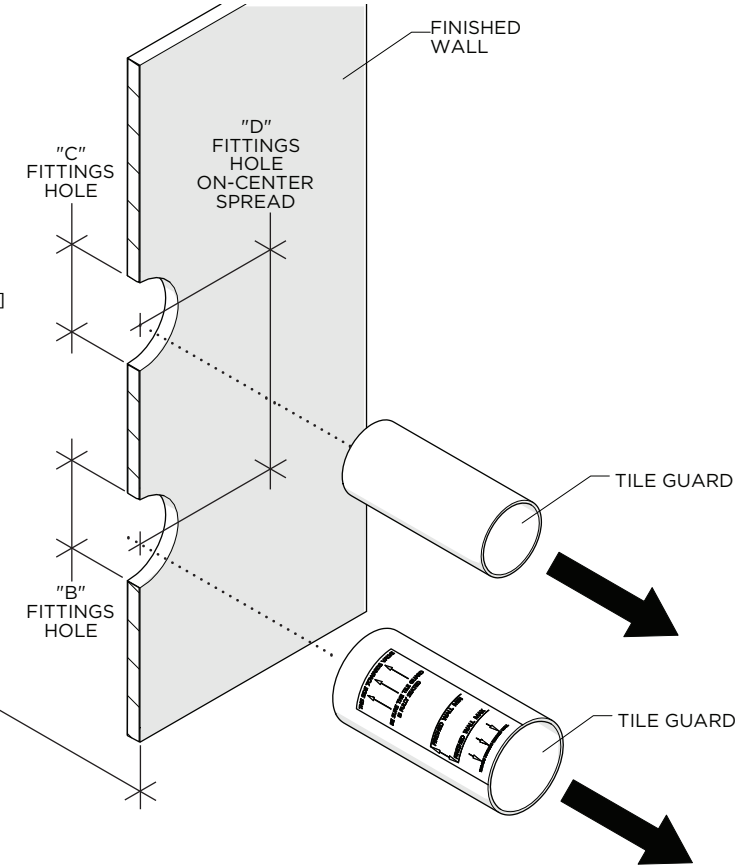
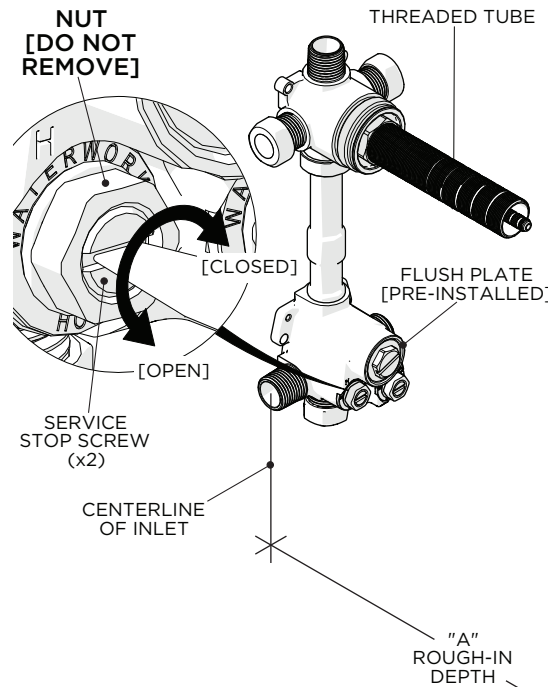

DIM	VALUE
A	4-1/2" [114mm] MAXIMUM 3-5/8" [92mm] MINIMUM
B	Ø2-1/2" [64mm]
C	Ø2" [51mm]
D	6-5/16" [160mm] [NOT ADJUSTABLE]

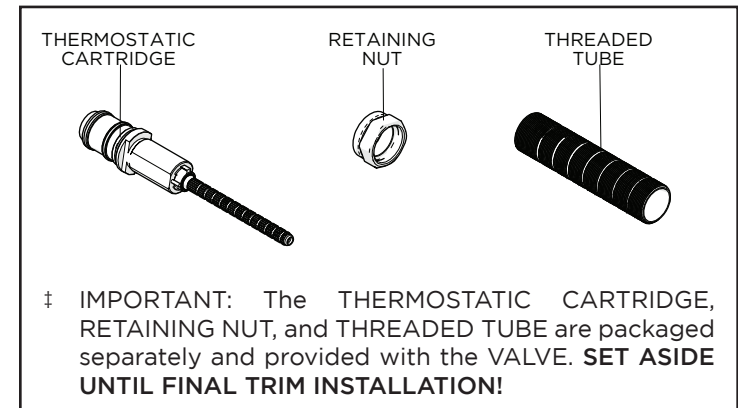

INSTALLATION GUIDELINES

THERMOSTATIC AND VOLUME CONTROL TRIMS

WATERWORKS

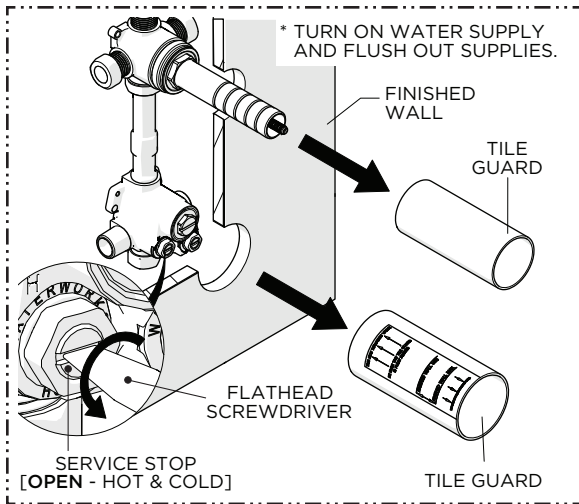

CAUTION: FAILURE TO FLUSH THE SUPPLY LINES WILL PERMANENTLY DAMAGE THE CARTRIDGE AND VOID THE WARRANTY! REPEAT THE FLUSHING PROCESS AS NEEDED BEFORE FINAL TRIM INSTALLATION.

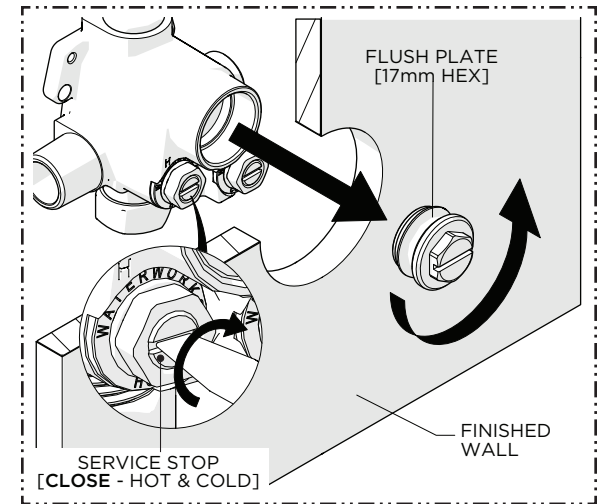

1. Turn on the water supplies then remove the TILE GUARDS from the VALVE and **OPEN** the SERVICE STOPS (hot & cold) and INTEGRATED VOLUME CONTROL VALVE to flush out the lines.

2. After the lines have been fully flushed, **CLOSE** the SERVICE STOPS (hot & cold) then unthread and remove the FLUSH PLATE.

NOTE: Do **NOT** discard the FLUSH PLATE.

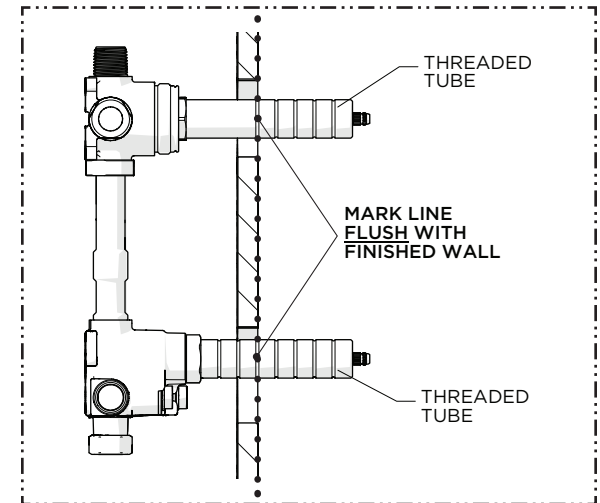
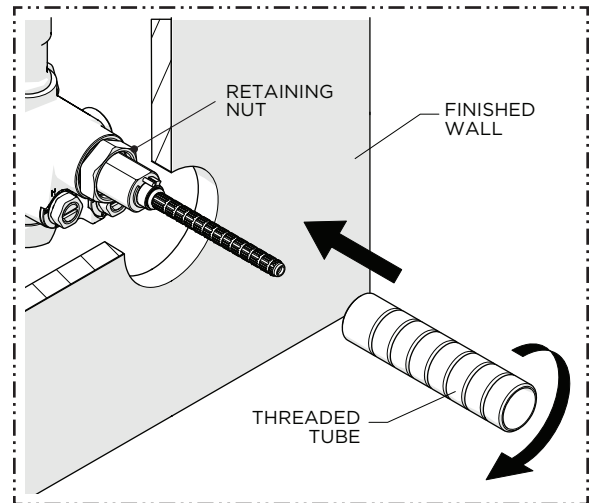
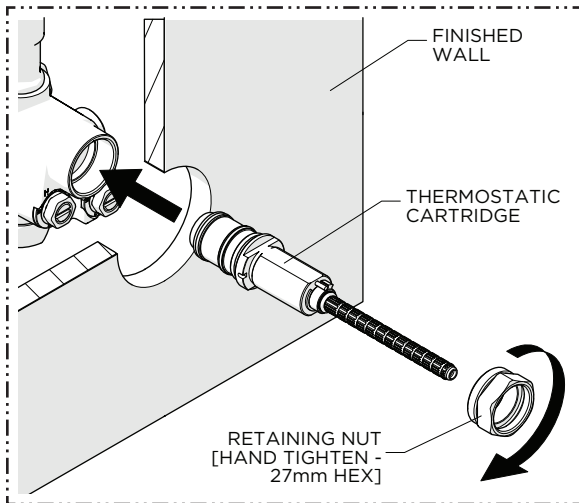

3. Insert the THERMOSTATIC CARTRIDGE into the VALVE BODY then thread and **hand-tighten** the RETAINING NUT into the VALVE BODY.

4. Thread the THREADED TUBE into the RETAINING NUT until snug.

5. Mark both TUBES where they protrude past the finished wall.

NOTE: A straight edge (not supplied) can be used to mark the TUBES.

INSTALLATION GUIDELINES

THERMOSTATIC AND VOLUME CONTROL TRIMS

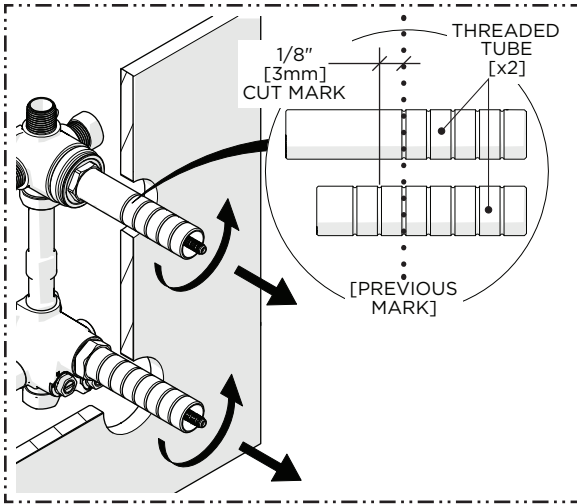

6. Remove the TUBES and cut them 1/8" [3mm] behind the previous mark so the TUBES will be 1/8" [3mm] below or recessed into the finished wall surface.

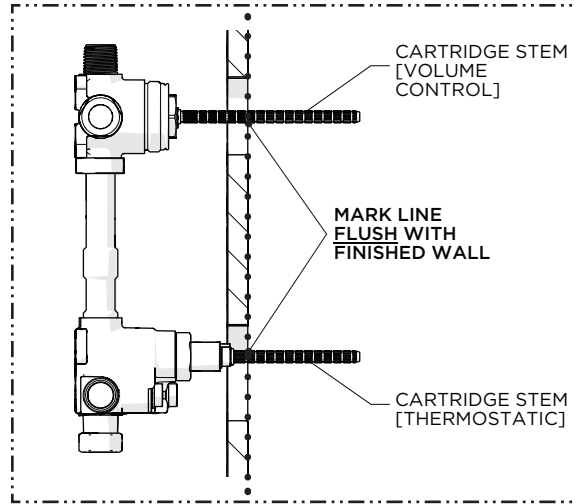

7. Mark both CARTRIDGE STEMS where they protrude past the finished wall.

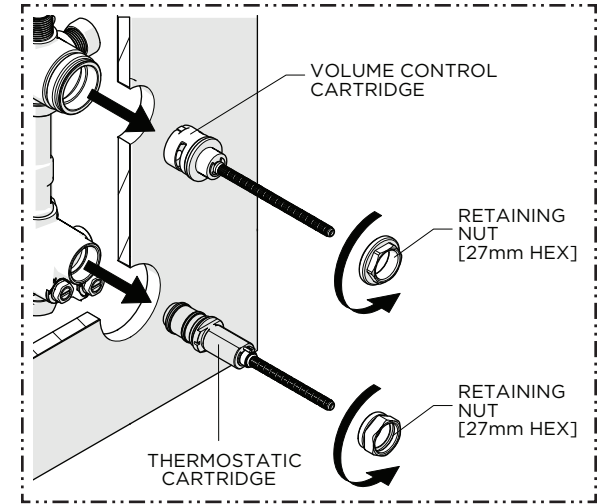

8. Unthread both RETAINING NUTS and remove both CARTRIDGES.

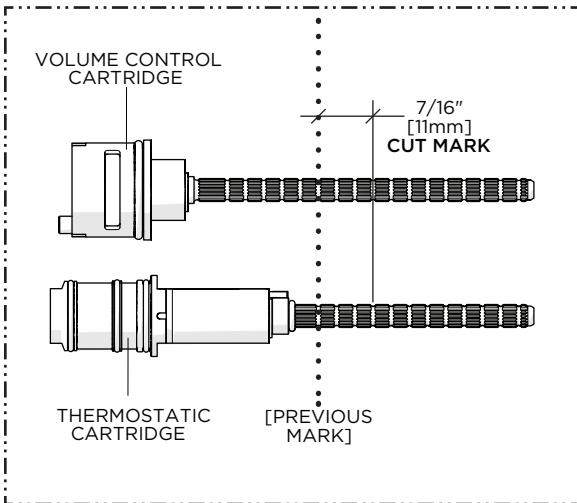

9. Carefully cut both CARTRIDGE STEMS 7/16" [11mm] in front of the previous mark so the STEMS will protrude 7/16" [11mm] from the finished wall surface.

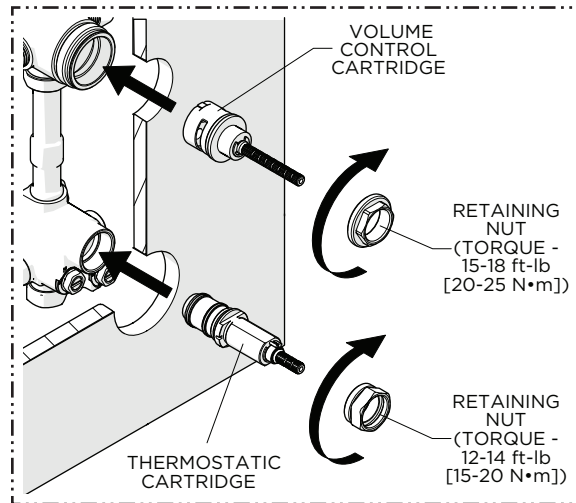

10. Insert both CARTRIDGES back into the VALVE BODY then thread and **securely** tighten the RETAINING NUTS to the specified torque settings shown.

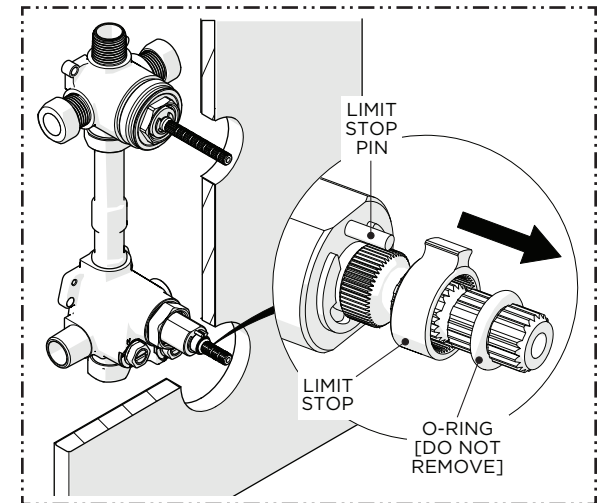

11. Slide the O-RING and LIMIT STOP on the THERMOSTATIC CARTRIDGE up the STEM.

NOTE: Do NOT remove or damage the O-RING.

INSTALLATION GUIDELINES

THERMOSTATIC AND VOLUME CONTROL TRIMS

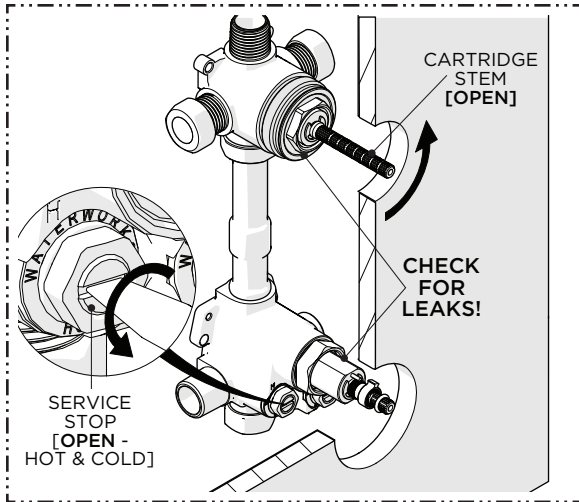

12. OPEN the SERVICE STOPS (hot & cold) and check for leaks. If no leaks are found, proceed and open the VOLUME CONTROL VALVE.

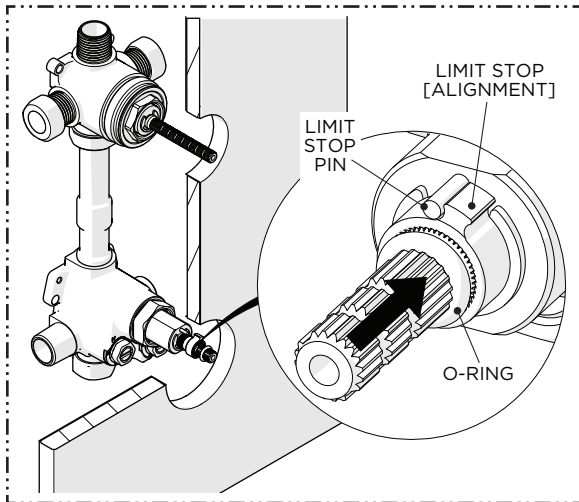

15. Slide the LIMIT STOP and O-RING back down the STEM making sure to properly align the LIMIT STOP with the LIMIT STOP PIN.

NOTE: The O-RING will prevent the LIMIT STOP from sliding off the STEM.

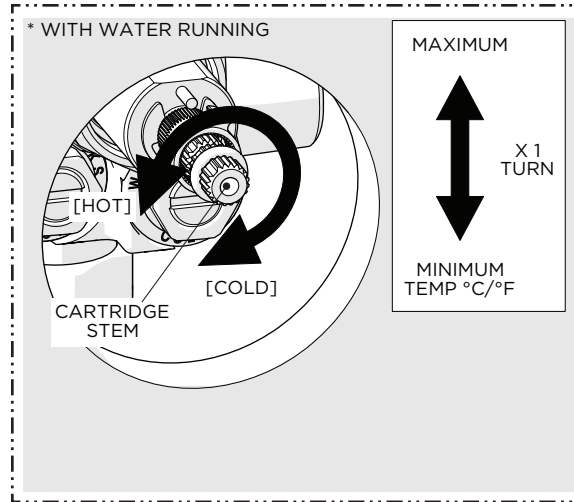

13. With water running, slowly rotate the THERMOSTATIC CARTRIDGE STEM clockwise to attain full cold then rotate it counterclockwise to attain full hot. Verify that a full range of temperatures exists.

NOTE: It's approximately 1 complete rotation.

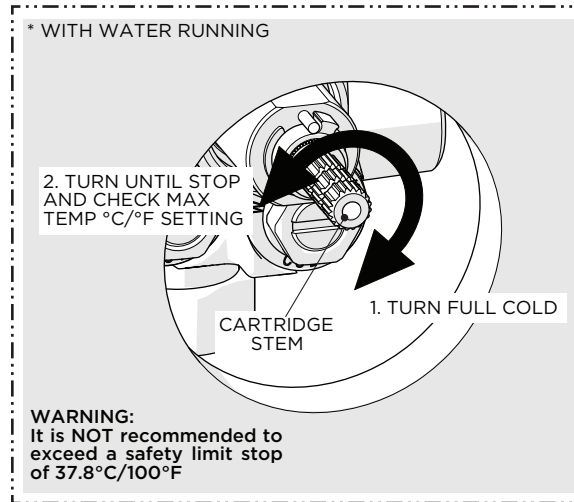

16. Re-open the VOLUME CONTROL VALVE then turn the THERMOSTATIC CARTRIDGE STEM clockwise to full cold then counterclockwise until snug. Verify the **maximum** desired bathing temperature set in the previous step then turn the water off.

WARNING: It is NOT recommended to exceed a safety limit stop of 37.8°C/100°F.

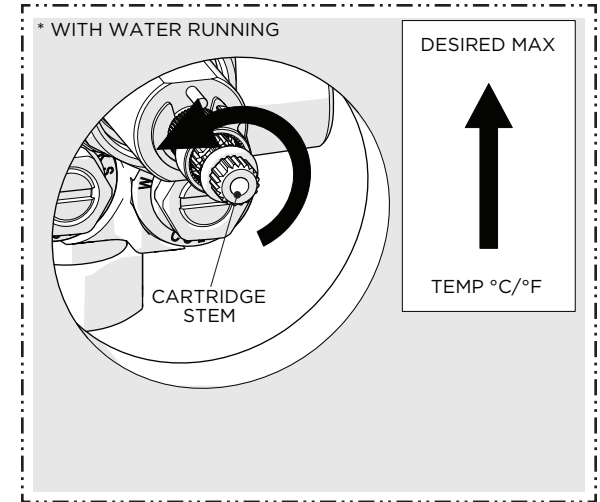

14. With water running, rotate the STEM to adjust the temperature to the **maximum** desired bathing temperature, verified with a thermometer, then close the VOLUME CONTROL VALVE and make sure **NOT** to change this setting.

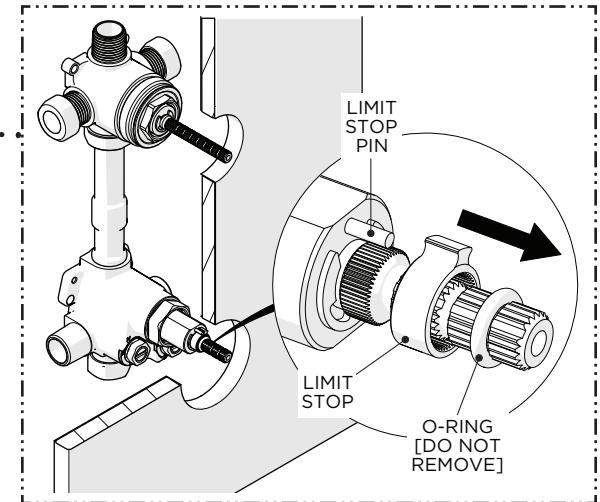

IF THE MAXIMUM BATHING TEMPERATURE IS NOT CORRECT OR NEEDS TO BE ADJUSTED:

17. Slide the O-RING and LIMIT STOP back up the STEM to disengage and **REPEAT** steps 13 through 16 to re-calibrate the temperature setting.

INSTALLATION GUIDELINES

THERMOSTATIC AND VOLUME CONTROL TRIMS

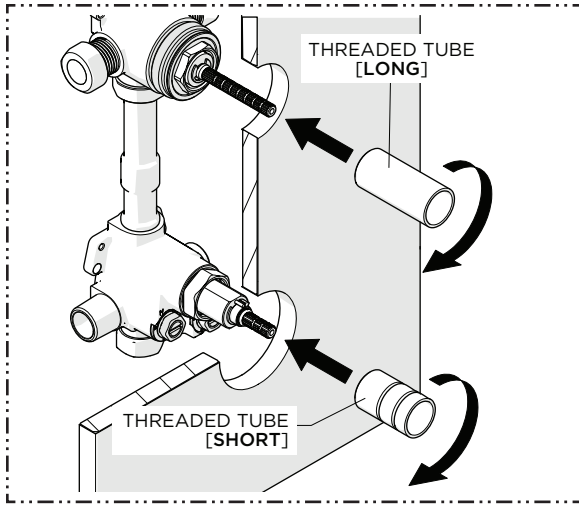

18. Thread the THREADED TUBES back into the RETAINING NUTS until snug.

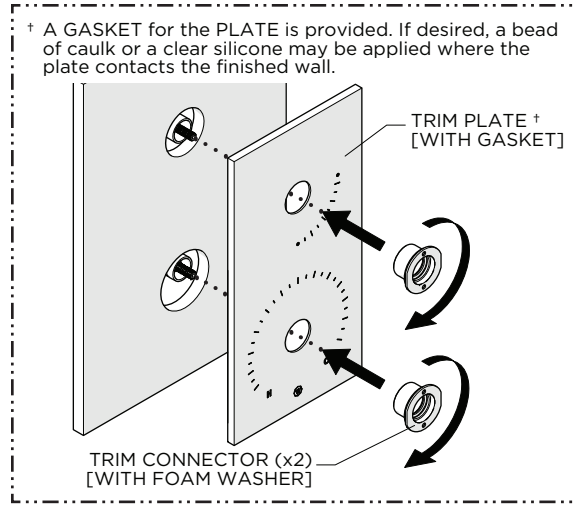

19. Firmly hold the TRIM PLATE against the finished wall then thread and securely tighten the TRIM CONNECTORS onto the TUBES making sure to use the FOAM WASHERS provided.

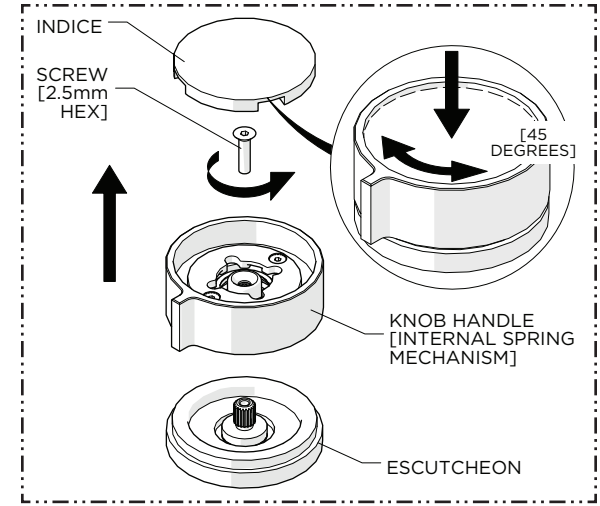

20. Remove the INDICE, center SCREW and KNOB HANDLE from the ESCUTCHEON. Do **NOT** remove the internal SPRING.

NOTE: To remove the INDICE push down on and rotate it 45 degrees then release.

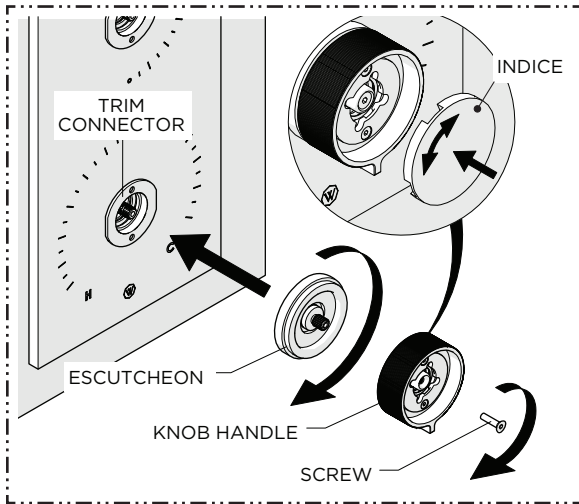

21. Fully thread the ESCUTCHEON into the TRIM CONNECTOR, place the KNOB HANDLE onto the ESCUTCHEON, thread and securely tighten the SCREW, and re-attach the INDICE.

➤ Repeat the previous steps to install the 2nd KNOB HANDLE or continue for LEVER HANDLE.

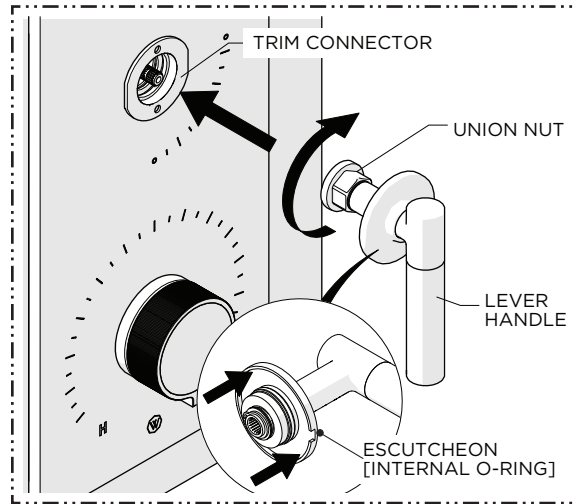

22. **CAREFULLY** slide the ESCUTCHEON up the LEVER HANDLE to expose the UNION NUT then thread the NUT into the TRIM CONNECTOR until snug.

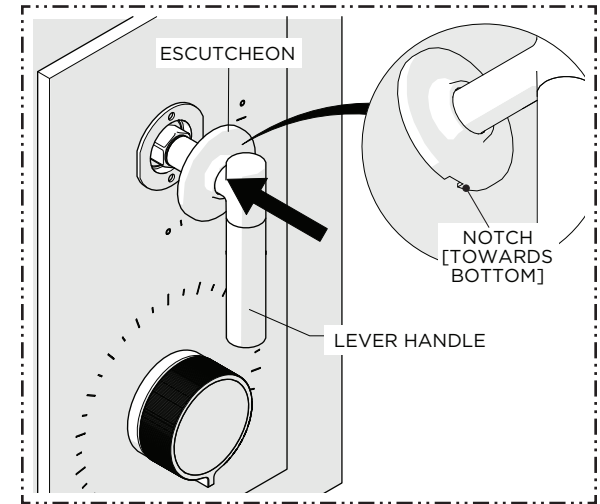

23. **CAREFULLY** slide the ESCUTCHEON down the LEVER HANDLE to conceal the TRIM CONNECTOR.

NOTE: The LEVER and KNOB HANDLE positions can be swapped depending on the user preference.