

.25

PTKM30

.25 One Hole High Profile Bar Faucet, Metal Handle



SHOWN IN .25 ONE HOLE HIGH PROFILE BAR FAUCET, METAL HANDLE| PTKM30

TECHNICAL DETAILS

ADA Compliance: When installed per ADA guidelines
Deck Thickness Maximum: 35 mm
Deck Thickness Minimum: 6 mm
Escutcheon Primary Material: Brass
Fittings Hole Diameter: 38 mm
Flow Restriction Options: 2.2, 1.5
Handle Turn Angle: Quarter Turn Each Way
Depth / Width: 213 mm
Height: 229 mm
Inlet Connection Size: 3/8"
Inlet Connection Type: Compression Connection Adapters
Integrated Diverter: N
Integrated Spray: N
Length: 60 mm
Number of Holes: One Hole
Restricted Maximum Flow Rate: 8.3 liters/min
Spout Swivel: N
Spray Included in Unit: N
Suggested Application: Bar, Kitchen, Laundry
Valve Material: Ceramic
Water Pressure Maximum: 6.0 bar
Water Pressure Minimum: 1.5 bar
Water Pressure Recommended: 3.0 bar

INSPIRATION

.25 is the ultimate in utilitarian elegance: A simple and understated design that is equally functional and beautiful.

CODES & STANDARDS

Code # PTKM30: CEC, ADA

PRODUCT FEATURES

Single Handle Control

Ceramic cartridge provides durability and long life

Pull Handle for volume adjustments and rotate left for hot and right for cold

Standard flow rate is 2.2gpm (8.3 L/min) and State of California requires a maximum of 1.8gpm(6.8 L/min). Also available in high efficiency flow options. Contact a sales associate for details.

.25

PTKM30

.25 One Hole High Profile Bar Faucet, Metal Handle

NOTE: IT IS NOT RECOMMENDED TO MOUNT THE HANDLE POSITIONED TO THE SIDE, THE SPOUT WILL MAKE CONTACT WITH THE HANDLE WHEN SWIVELING. IF A SIDE MOUNTED HANDLE IS REQUIRED, PLEASE ORDER THE PTKM35.

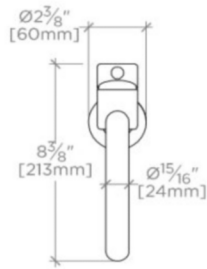

TOP VIEW SCALE: 1 1/2" = 1'-0"

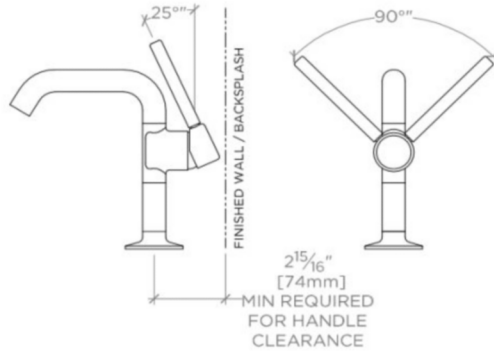

HANDLE OPERATION



FRONT VIEW SCALE: 1 1/2" = 1'-0"

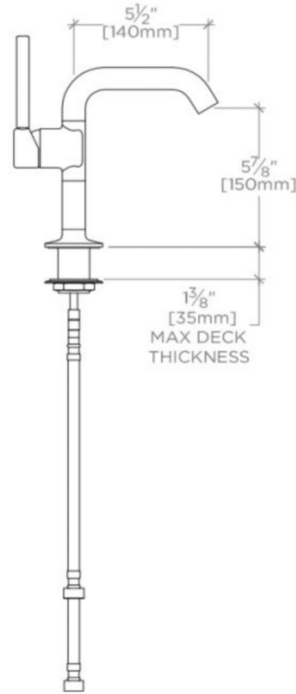

SIDE VIEW

SCALE: 1 1/2" = 1'-0"