

# INSTALLATION GUIDELINES

## EXPOSED TUB FILLER

### HIGHGATE EXPOSED TUB FILLER WITH HANDSHOWER AND HANDLES

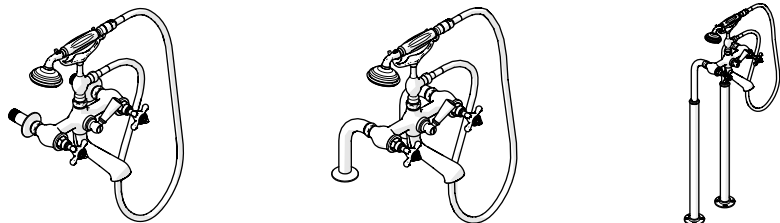

STYLE		
HGXT20 [SHOWN]	HGXT40 [SHOWN]	HGXT60 [SHOWN]
HG20XT	HG40XT	HGXT1C

#### IMPORTANT:

- To ensure this product is installed properly, you must read and follow these guidelines.
- The owner/user of this product must keep this information for future reference.
- This product must be installed by a professional licensed contractor and must be on-site prior to rough-in. This allows the installer to visualize the installation and verify the 7-5/8" [193mm] on-center inlet supply spread. The inlet supply spread on this product is **NOT** adjustable.
- **DECK MOUNTED TUB FILLERS ONLY:** An access panel must be installed for servicing and installation.
- Check TUB measurements to assure the SPOUT projects far enough into the TUB.
- Run 3/4" supply lines for **MAXIMUM** flow and install **ACCESSIBLE** hot and cold service stop valves to facilitate servicing.
- Be sure your installation conforms to all federal, state, and local codes.
  - Anti-scald protection is the responsibility of the installer and according to applicable codes.
  - A water temperature limiting device is the responsibility of the installer and must be in accordance with ASSE 1070.
  - In the State of Massachusetts, all installations must comply with the rules and regulations set forth within 248 CMR.
- Inspect this product to ensure you have all the parts required for proper installation. Product is sold partially assembled but shown fully disassembled for illustrative and service purposes only.
- Use only a strap wrench or protected/smooth-jaw wrench on **ANY** finished surface.

- The use of certain plumber's putty may stain stone or tile surfaces.
- If further assistance is required, please contact Product Support at 1-800-927-2120 Monday through Friday, 8am - 6pm EST.
- Refer to the separate Service Parts Documents for available replacement parts.

#### TECHNICAL DETAILS:

DETAIL	STYLE	SPECIFICATION
ADJUSTABLE VERSUS FIXED SPRAY [HANDSHOWER - ONLY]	ALL	FIXED
DIAMETER OF HANDSHOWER HEAD	ALL	2-3/4" [70mm]
FITTINGS HOLE DIAMETER	HGXT20, HG20XT, HGXT40, HG40XT	1-1/4" [32mm]
	HGXT60	1-1/8" [29mm]
HANDLE TURN ANGLE	ALL	QUARTER TURN
HOSE LENGTH	ALL	60" [1.54m]
INLET CONNECTION	HGXT20, HGXT40	3/4" MALE NPT
	HG20XT, HG40XT	3/4" MALE BSPP <sup>+</sup>
	HGXT60	3/4" COPPER SWEAT
INLET SUPPLY SPREAD	ALL	7-5/8" [193mm] <b>[NOT ADJUSTABLE]</b>
INTEGRATED DIVERTER	ALL	YES
SPOUT REACH	HGXT20, HG20XT	8-7/8" [226mm] <b>MAXIMUM</b> 7-5/8" [194mm] <b>MINIMUM</b>
	HGXT40, HG40XT	9-13/16" [249mm]
	HGXT60	10-1/8" [257mm]
WATER PRESSURE RANGE	ALL	85psi [6.0 bar] <b>MAXIMUM</b> 20psi [1.5 bar] <b>MINIMUM</b>
WATER PRESSURE RECOMMENDED	ALL	45psi [3.0bar]

<sup>+</sup> Style No. **HG40XT** provided with **2 BSPP ADAPTERS**. ADAPTERS are packaged separately and assembly is required. Replacement ADAPTERS can be ordered separately:

- Universal 3/4" NPT Female x 3/4" Male BSPP Adapter  
Style No. UNUK05

# INSTALLATION GUIDELINES FOR WALL UNIONS

## EXPOSED TUB FILLER

WATERWORKS

### ROUGH IN:

- **WARNING:** The inlet supply spread on this product is **NOT** adjustable. If the rough-in is **NOT** accurate it will make the installation difficult or impossible.
- Run well supported 3/4" hot and cold copper supply lines for **MAXIMUM** water flow and install 3/4" FEMALE NPT ADAPTERS† (not supplied) making sure the ADAPTERS are:
  - Securely anchored/strapped,
  - Level,
  - Perpendicular to the finished wall,
  - Parallel to each other,
  - At the proper spread of 7-5/8" [193mm] and
  - At equal depths.
- **IMPORTANT:** The final distance the UNIONS must project from the surface of the finished wall must be between a **MAXIMUM** of 2-1/4" [57mm] and a **MINIMUM** of 1" [25mm].

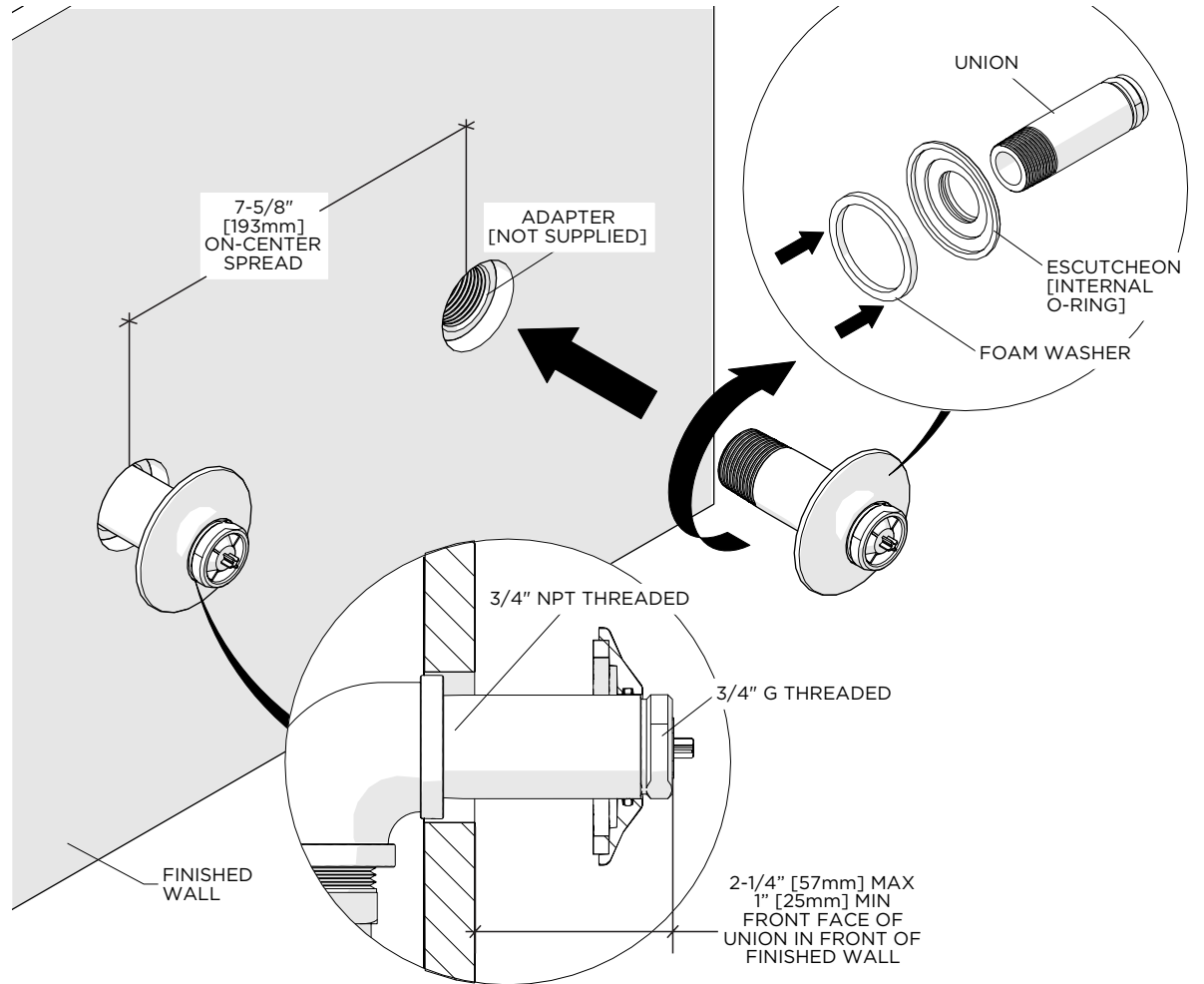

1. Verify the 7-5/8" [193mm] inlet supply spread then slide an ESCUTCHEON and FOAM WASHER onto each UNION.
2. Thread and securely tighten the UNIONS into the 3/4" FEMALE NPT ADAPTERS † (not supplied) making sure the UNIONS are at equal depths and project between 2-1/4" [57mm] **MAXIMUM** and 1" [25mm] **MINIMUM** from the finished wall.
3. **PROCEED TO THE TUB FILLER INSTALLATION SECTION.**

† UK Style No. **HG20XT** are supplied with 3/4" MALE x 3/4" MALE **BSPP** UNIONS.

# INSTALLATION GUIDELINES FOR DECK UNIONS

## EXPOSED TUB FILLER

### ROUGH IN:

- **WARNING:** The inlet supply spread on this product is **NOT** adjustable. If the rough-in is **NOT** accurate it will make the installation difficult or impossible.
- Run well supported 3/4" hot and cold copper supply lines for **MAXIMUM** water flow.
- **CAUTION:** An access panel must be installed for servicing and installation.

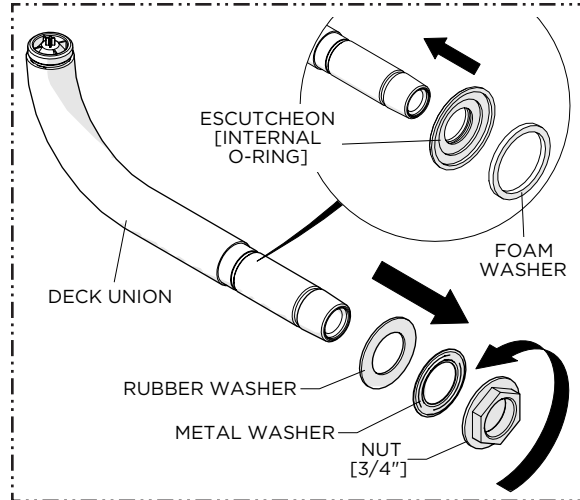

1. Remove the MOUNTING HARDWARE from each UNION then slide an ESCUTCHEON and FOAM WASHER onto each UNION making sure they are fully seated.

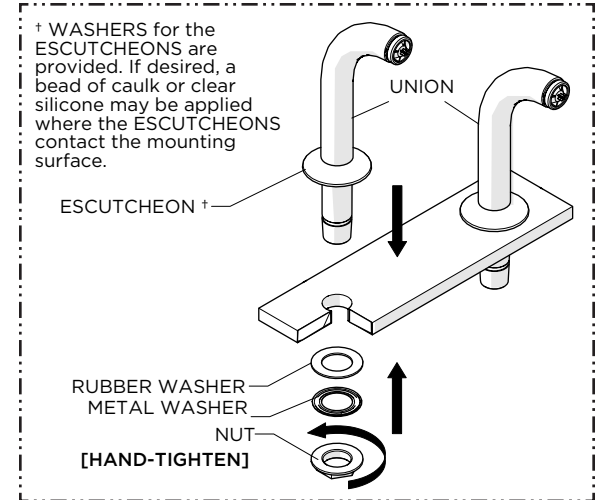

2. Insert each UNION through the hole on the mounting surface then re-install the MOUNTING HARDWARE and hand-tighten the NUT.

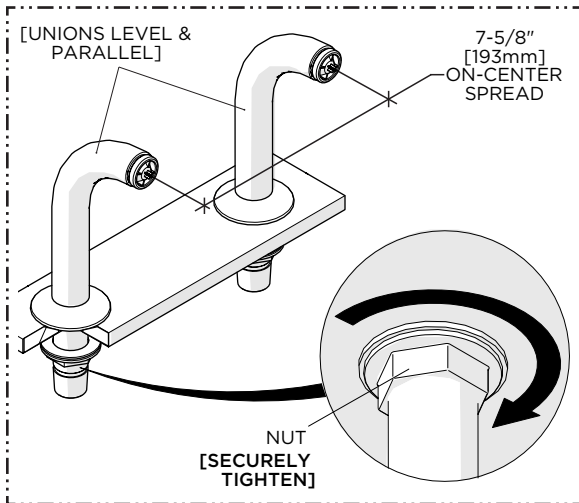

3. Verify the UNIONS are level, parallel to each other, and at the proper 7-5/8" [193mm] on-center spread then securely tighten the NUTS.

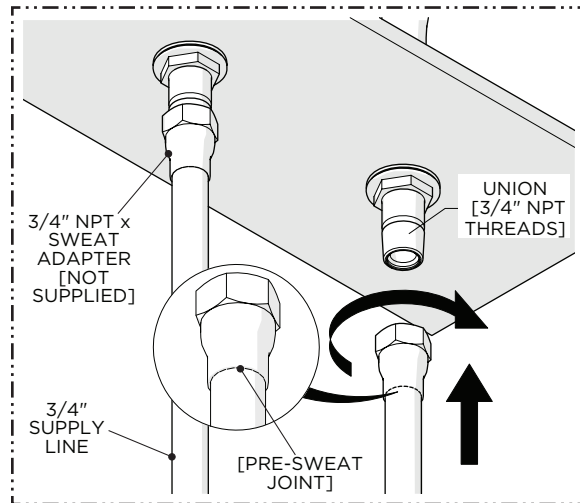

4. Pre-sweat 3/4" NPT x sweat ADAPTERS to the supply lines and let cool. Apply a thin coat of pipe thread sealant to the NPT threads on the UNIONS then thread and securely tighten the ADAPTERS onto the UNIONS.

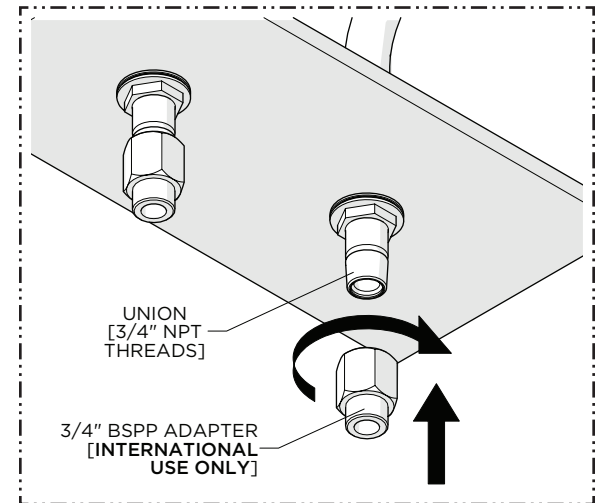

### FOR INTERNATIONAL INSTALLATIONS ONLY:

5. 3/4" female NPT x 3/4" male BSPP ADAPTERS are provided. Thread and securely tighten the ADAPTERS onto the UNIONS.

➤ **PROCEED TO THE TUB FILLER INSTALLATION SECTION.**

# INSTALLATION GUIDELINES FOR FLOOR UNIONS

WATERWORKS

## EXPOSED TUB FILLER

### ROUGH IN:

- **WARNING:** The inlet supply spread on this product is **NOT** adjustable. If the rough-in is **NOT** accurate it will make the installation difficult or impossible.
- Run well supported 3/4" hot and cold copper supply lines for **MAXIMUM** water flow. The 3/4" supply lines must be:
  - Securely anchored/strapped below sub-floor,
  - Level,
  - Perpendicular to the finished floor,
  - Parallel to each other, and
  - At the proper spread of 7-5/8" [193mm].
- Wood blocking is **REQUIRED** and should be no further than 1" from the finished floor for the MOUNTING SCREWS to create adequate support for the TUB FILLER.

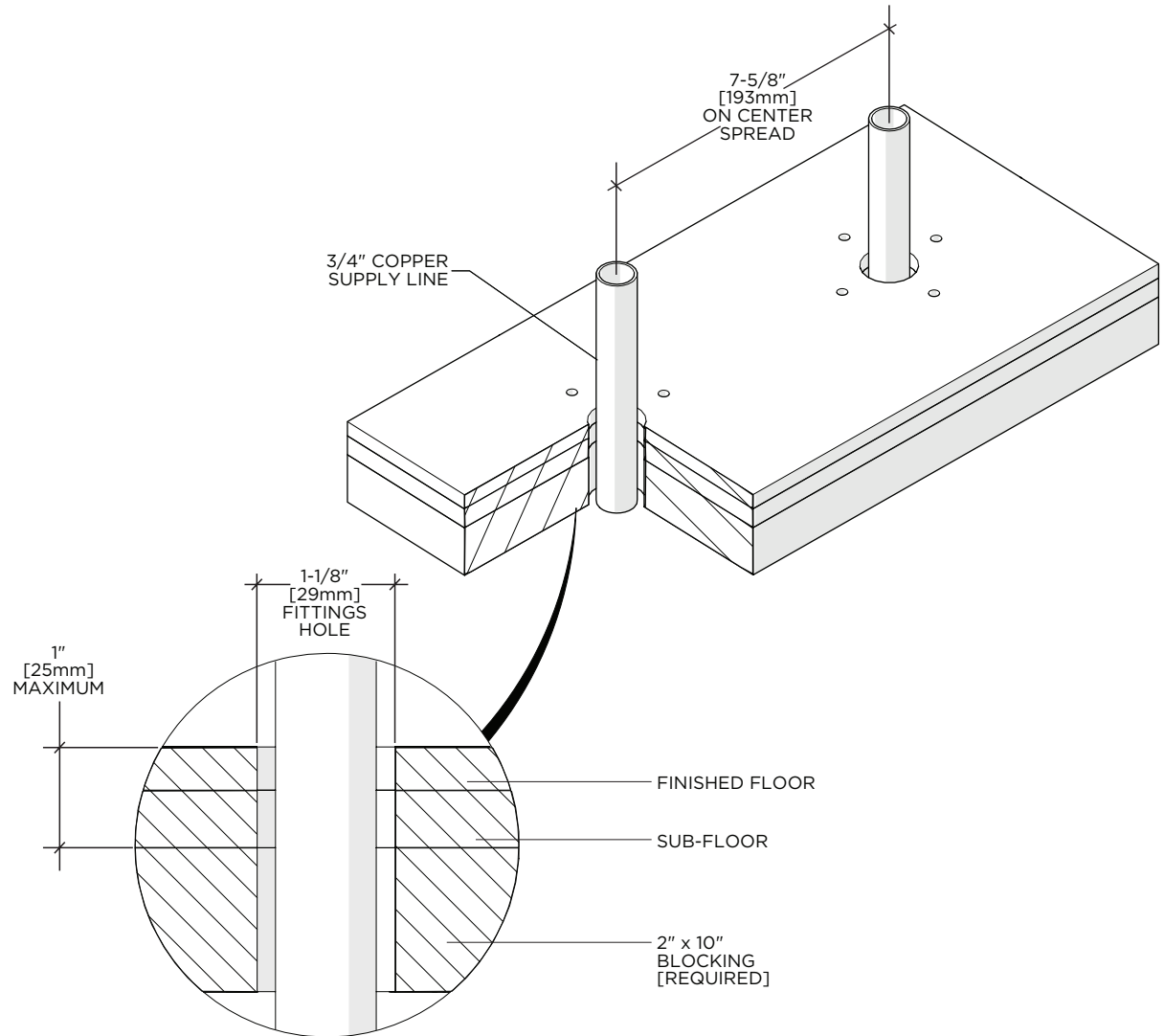

1. Rough-in and verify the 7-5/8" [193mm] inlet supply spread then refer to the INSTALLATION GUIDELINES provided **SEPARATELY** with the FLOOR UNIONS (**Style No. UNUN32 or UNUN60**) to properly install the UNIONS.
2. **PROCEED TO THE TUB FILLER INSTALLATION SECTION.**

# INSTALLATION GUIDELINES

## EXPOSED TUB FILLER

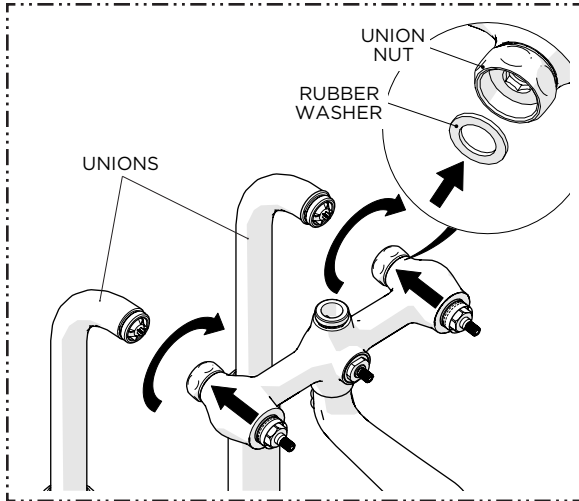

1. Using the RUBBER WASHERS provided, hold the TUB FILLER up to the UNIONS then thread and securely tighten the UNION NUTS onto the UNIONS.

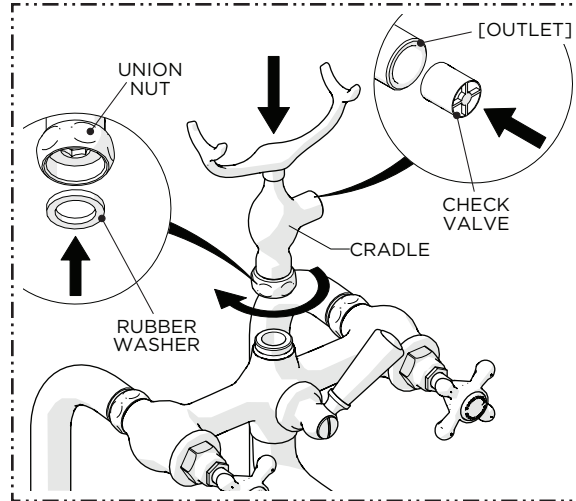
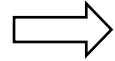

2. Using the RUBBER WASHER provided, thread and securely tighten the HANDSHOWER CRADLE onto the TUB FILLER.

**NOTE:** The CRADLE can be installed with the outlet either on the left or right side and a CHECK VALVE is located inside the outlet of the CRADLE.

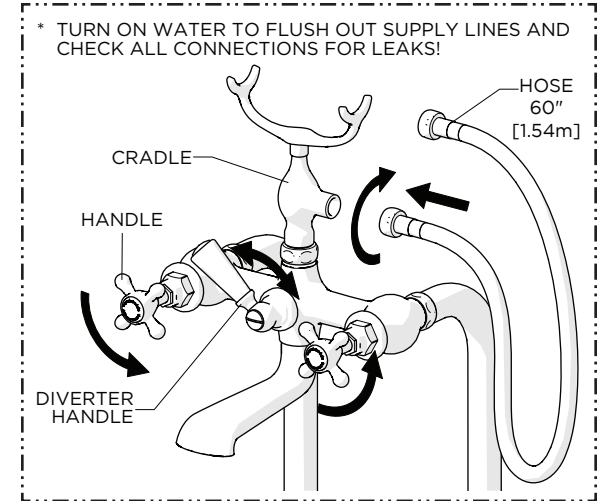
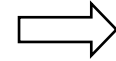

3. Thread the HOSE onto the CRADLE then turn on the water to flush out the supply lines and check all connections for leaks.

Operate the DIVERTER HANDLE to ensure it functions properly before installing the HANDSHOWER.

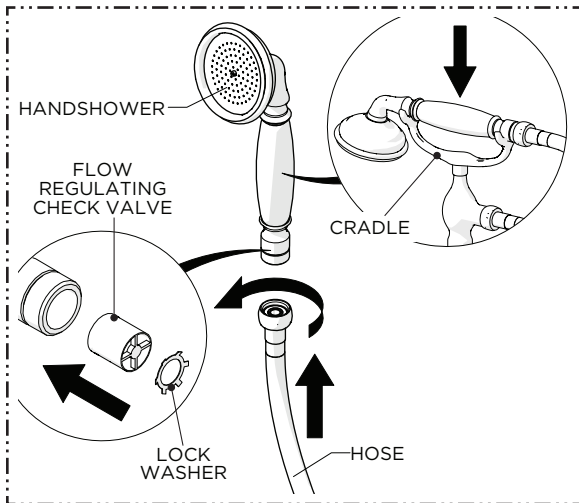

4. Thread the HOSE onto the HANDSHOWER and ensure it rests properly on the CRADLE.

**NOTE:** A FLOW REGULATING CHECK VALVE is located inside the inlet of the HANDSHOWER.

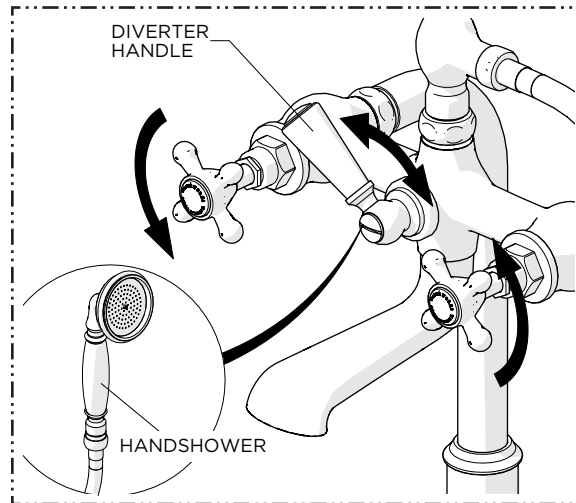

5. With water running, operate the DIVERTER HANDLE to ensure the HANDSHOWER functions properly.

# SERVICE GUIDELINES

## EXPOSED TUB FILLER

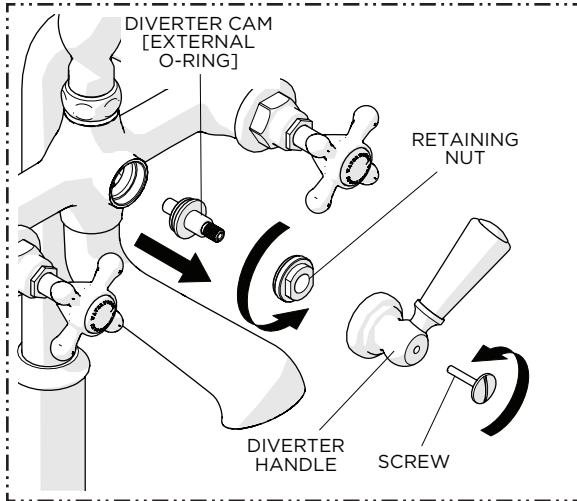

### SERVICING THE DIVERTER:

1. Carefully unthread the SCREW then remove the DIVERTER HANDLE and GLAND COVER.

Unthread the RETAINING NUT and remove the DIVERTER CAM.

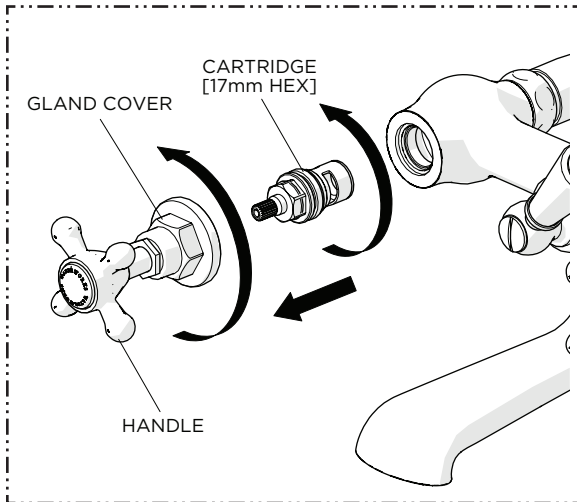

### SERVICING THE CARTRIDGE:

1. Unthread the GLAND COVER to remove the HANDLE then unthread the CARTRIDGE using a 21/32" [17mm] shower valve socket wrench (not provided).

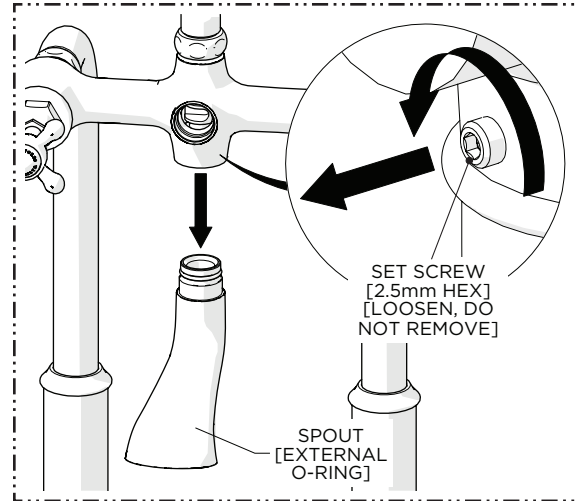
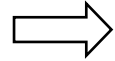

2. Loosen, but do NOT remove, the SET SCREW behind the TUB FILLER then remove the SPOUT.

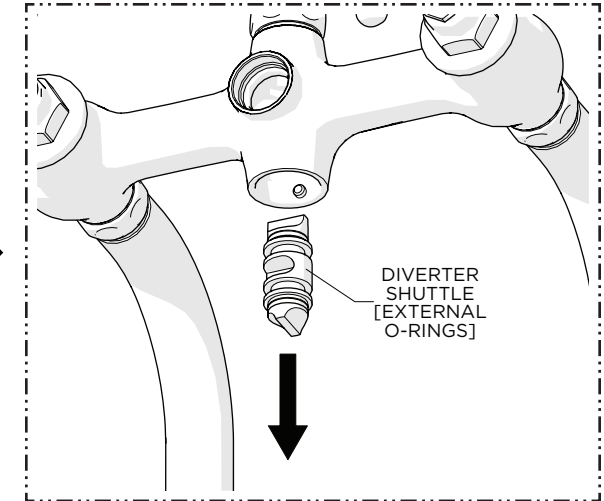
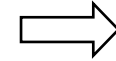

3. Remove the DIVERTER SHUTTLE from below.