

WATERWORKS INSTALLATION GUIDELINES

STYLE No. ETW101

Essentials Classic 110v Single Rail Towel Warmer

3 1/4" x 19 11/16" x 5 11/16"

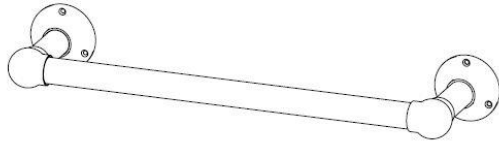

TECHNICAL DETAILS:

DETAIL	SPECIFICATION
DIAMETER OF TUBES	1 1/4" [32mm]
PRIMARY MATERIAL	Brass
WEIGHT	6.5lbs [3KG]
APPROXIMATE POWER OUTPUT	12W
IP RATING	IP67
APPROXIMATE TEMPERATURE (AT NORMAL ROOM TEMP)	110 °F [45°C]
STANDARD POWER CABLE LENGTH	8 Ft [2.4m]
VOLTAGE	110V
APPROXIMATE CURRENT	0.11A

IMPORTANT:

- This guide is for standard size only, for bespoke sizes data refer to issued test certificate.
- To ensure this product is installed properly, you must read and follow these guidelines.
- The owner/user of this product must keep this information for future reference.
- Install adequate blocking or position over a stud to properly secure the fixture.
- Inspect this product, upon receiving, to ensure it is the correct model and you have all parts required for proper installation.
- This product must be installed by a professional licensed contractor. Be sure your installation conforms to all federal, state, and local codes.
- Take all necessary precautions to ensure that this product is protected during installation.

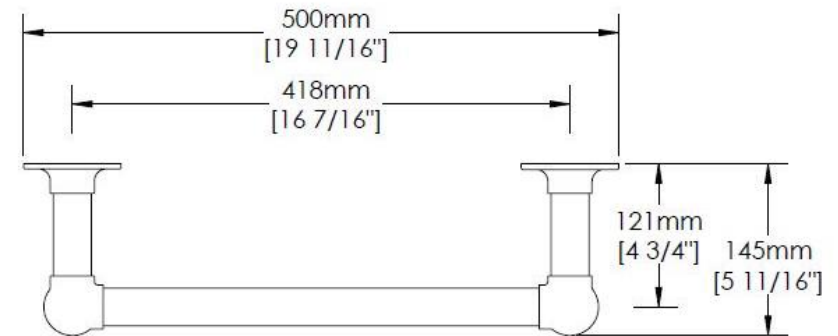

WATERWORKS INSTALLATION GUIDELINES

STYLE No. ETW101

Essentials Classic 110v Single Rail Towel Warmer

3 1/4" x 19 11/16" x 5 11/16"

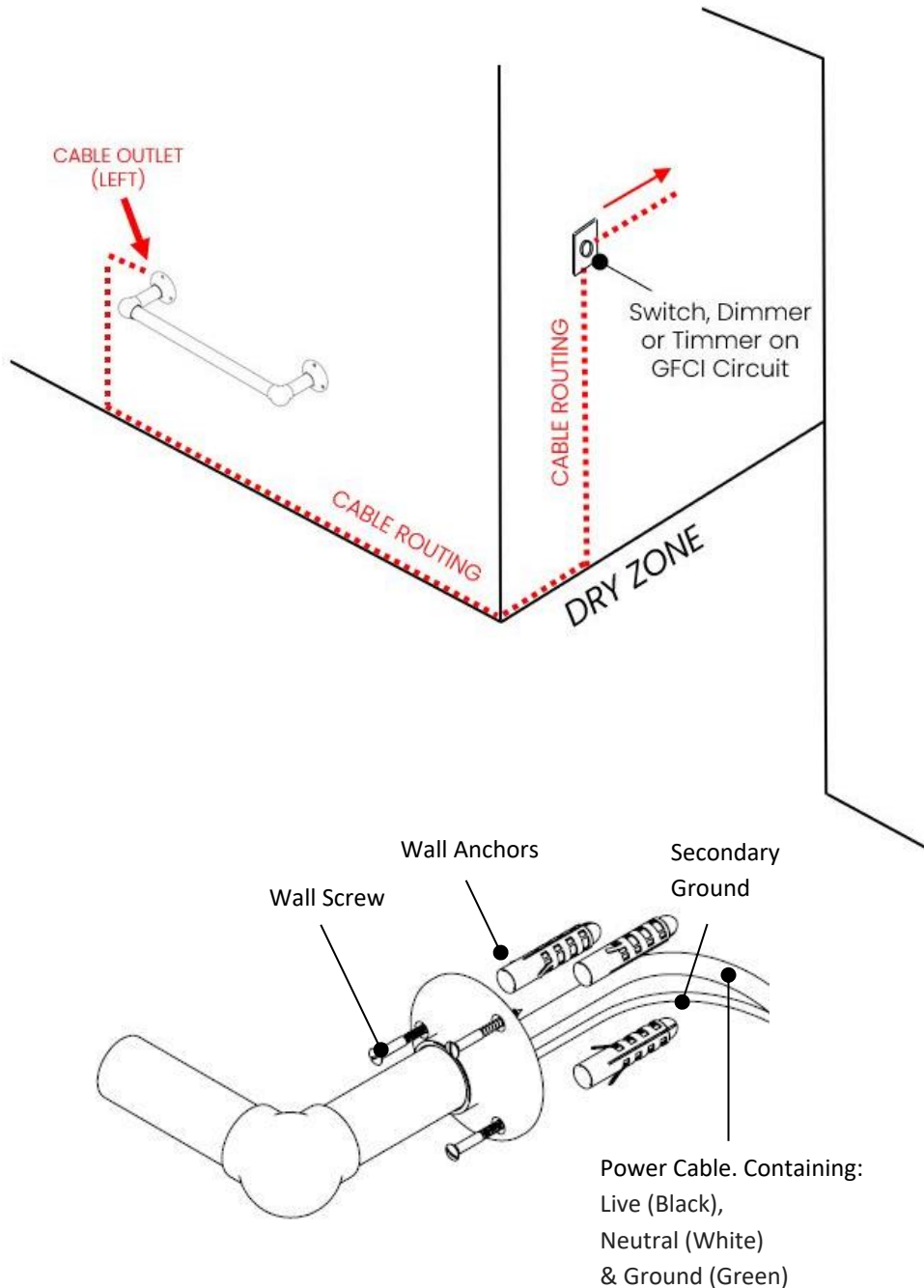

Method of Installation

1. Mark and drill holes for the Wall Screw / Wall Anchors at the appropriate positions. Check they are level using a spirit level.
2. After feeding the Supply and ground cord through the wall, secure with the wall screws. CARE SHOULD BE TAKEN not to scratch the towel warmer with the screwdriver.
3. Commence making the electrical connections. Recommended to be protected by a GFCI Circuit, refer to local and national code requirements.
4. Test by turning on the power and check temperature after 1 hour.

POSITIONING:

As supplied the towel warmer is IP67 rated and if installed in-line with these guidelines is suitable for all areas (wet and dry) of the bathroom. Measure the center distances of your towel warmer for the correct positioning.

CABLE ROUTING:

The towel warmer power cable should be routed through the wall to the domestic power supply. To maintain the IP67 protection, DO NOT cut the supply cord short to make the connection to the power supply within a wet zone. Feed the continuous cable through the wall cavity to make the connection at the controller or junction box inside a dry zone unless measures are taken to keep the connections free from moisture. The cable should be run through a suitable conduit that comply with local and national code requirements (cable should not be hard plastered into the wall). If a cable needs to be prepared before receiving the towel warmer (first fix) then a tracer/dummy cable should be in place to then pull the hardwired towel warmer cable through when installing. Avoid aggressively pulling the power cable during installation as this can damage the element inside.

TEMPERATURE CONTROL:

The towel warmer is low powered and reach a surface temperature of 110°F. In most cases they do not need to be altered from the default temperature and can be wired directly to the switch which is protected by an GFCI Circuit. If temperature control is still needed, a leading-edge dimmer switch is recommended. Although other manufacturers timers / smart home systems can also be installed in conjunction with the towel warmer if compatible (refer to suppliers' documentation). As the towel warmer is not a room heater, thermostats are not required.

FOR MULTIPLE RAIL INSTALLATION:

The towel rails having a low power consumption, they can be installed in any quantity, to suit your application. Each rail will have its own hardwired cabling that should be connected at a junction box (within dry zone) before wiring to a common controller.