

INSTALLATION GUIDELINES

INTEGRATED THERMOSTATIC

FINOT INTEGRATED THERMOSTATIC AND VOLUME CONTROL TRIM

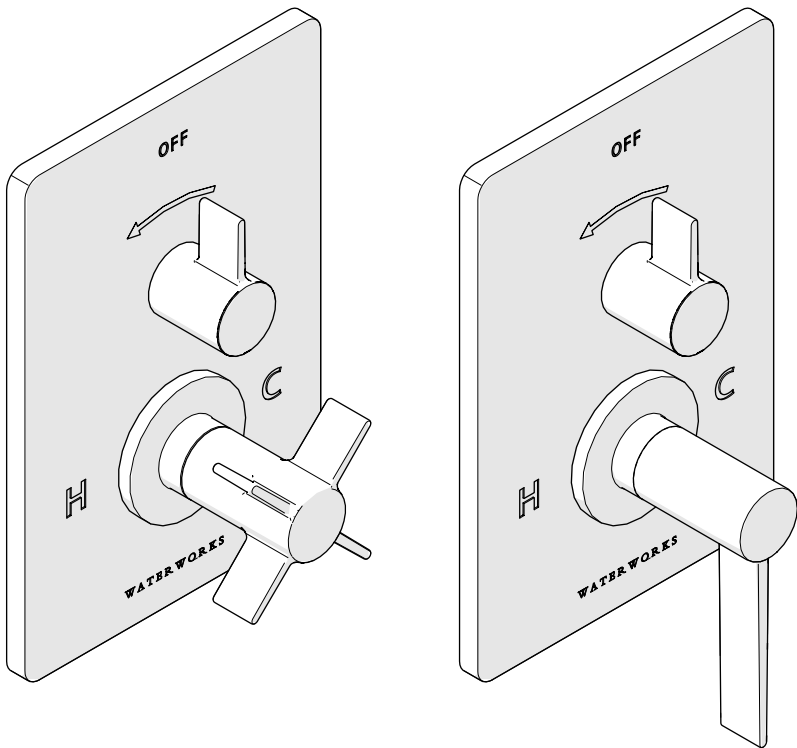

STYLES

NVT110 [SHOWN]

NVT120 [SHOWN]

NVT160

WATERWORKS

REQUIRED PLUMBING DETAILS:

- ViaBox™ 1/2" Integrated Thermostatic Valve with Volume Control.

STYLE No. GUTH61

IMPORTANT:

- To ensure this product is installed properly, you must read and follow these guidelines.
- The owner/user of this product must keep this information for future reference.
- This product must be installed by a professional licensed contractor and must be onsite prior to rough-in. This allows the installer to visualize the installation.
- **ALL VALVES AND TRIMS SOLD SEPARATELY.**
- This product is intended to work with the ViaBox™ 1/2" Integrated Thermostatic Valve with Volume Control (Style No. **GUTH61**). Refer to the Installation Guidelines provided with the VALVE for complete rough-in installation details and related information.
- Be sure your installation conforms to all federal, state, and local codes. In the State of Massachusetts, all installations must comply with the rules and regulations set forth within 248 CMR.
- **WARNING:** The **GUTH61** features anti-scald protection. The risk of scalding exists until the installer has properly calibrated/adjusted the temperature setting during final TRIM installation.
- This product is sold partially assembled but shown fully disassembled for illustrative and service purposes only.
- Inspect this product to ensure you have all the parts required for proper installation.
- Use only a strap wrench or protected/smooth-jaw wrench on any finished surface.
- The use of certain plumber's putty may stain stone or tile surfaces.
- If this product will remain unused for an extended period of time (over 3 months), then the water to the THERMOSTATIC VALVE should be shut off (via service stops or system control valve) and the INTEGRATED VOLUME CONTROL VALVE should be opened to allow the water in the THERMOSTATIC VALVE to evaporate. This is to keep the THERMOSTATIC CARTRIDGE from being exposed to stagnant or hard water, which can cause the VALVE to malfunction.
- If further assistance is required, please contact Product Support at 1-800-927-2120 Monday through Friday, 8am - 6pm EST.
- Refer to the separate Service Parts Documents for available replacement parts.

INSTALLATION GUIDELINES

INTEGRATED THERMOSTATIC

VALVE FUNCTION AND HANDLE OPERATION:

- The THERMOSTATIC VALVE only mixes hot and cold water, it does not have an on/off/volume control function. Mixed water flows out at a fixed volume to the INTEGRATED VOLUME CONTROL VALVE which has 2 positions.
 - 1 ON position that can direct water flow to a **MAXIMUM** of 1 device.
 - 1 OFF position.
 - The INTEGRATED VOLUME CONTROL VALVE incorporates tactile feedback at each position.

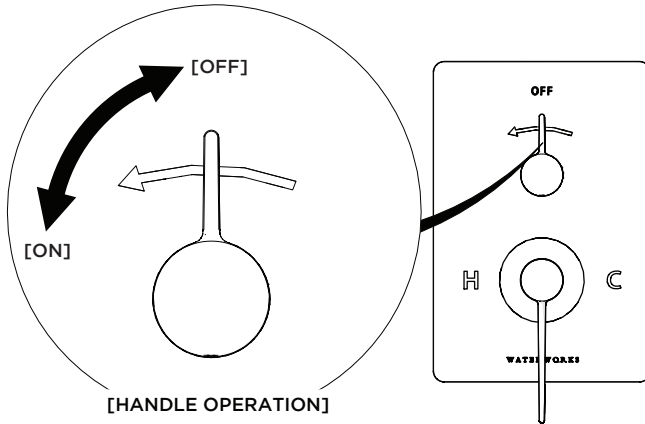

ROUGH-IN AND VALVE PREPARATION:

- The VALVE is provided with pre-installed FLUSH PLATES. The CARTRIDGES, RETAINING NUTS, and THREADED TUBE are packaged separately and provided with the VALVE.
- **IMPORTANT:** Make sure the supply lines are flushed prior to final TRIM installation using the FLUSH PLATES provided. Refer to the Installation Guidelines provided with the VALVE for further information.
- **CAUTION:** The rough-in depth is measured from the centerline of the inlets to the surface of the finished wall. If the VALVE is roughed-in too shallow, the TRIM cannot be installed correctly.
- Do **NOT** remove the COVER until final TRIM installation and ensure the finished wall is within the **MAXIMUM** and **MINIMUM** markings on the ViaBox™.

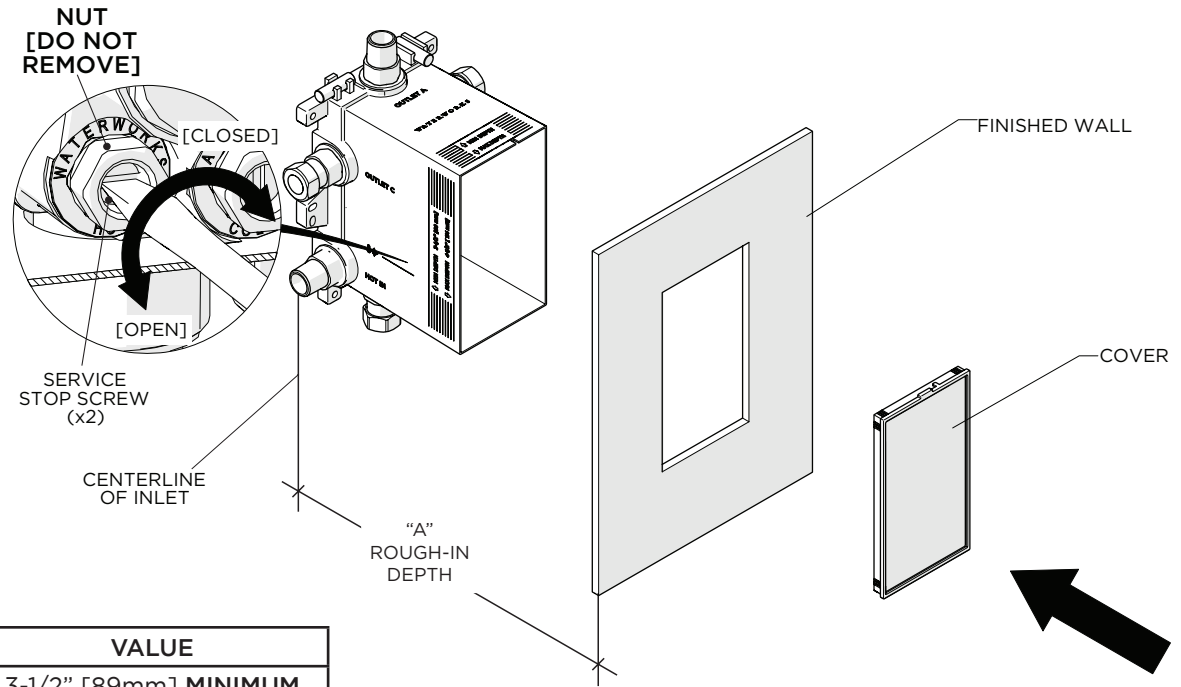

DIM	VALUE
A	3-1/2" [89mm] MINIMUM
	4-1/2" [114mm] MAXIMUM

IMPORTANT: The VOLUME CONTROL CARTRIDGE and RETAINING NUT are packaged separately and provided with the VALVE. **SET ASIDE UNTIL FINAL TRIM INSTALLATION!**

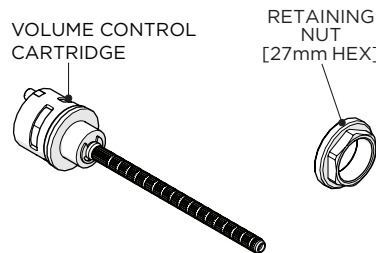

- ‡ SERVICE PART
- VOLUME CONTROL CARTRIDGE KIT
STYLE No. 100242

IMPORTANT: The THERMOSTATIC CARTRIDGE, RETAINING NUT, and THREADED TUBE are packaged separately and provided with the VALVE. **SET ASIDE UNTIL FINAL TRIM INSTALLATION!**

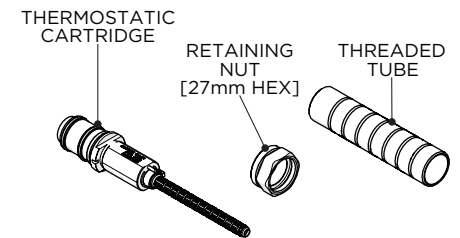

- ‡ SERVICE PART
- THERMOSTATIC CARTRIDGE KIT
STYLE No. 100219

INSTALLATION GUIDELINES

INTEGRATED THERMOSTATIC

WATERWORKS

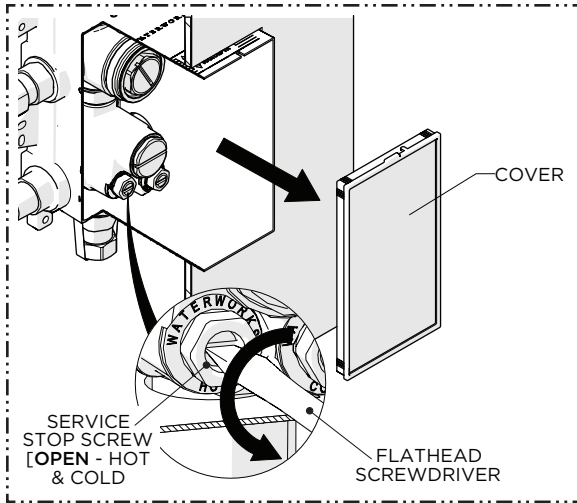

1. Turn on the water supplies then remove the COVER from the ViaBox™ and OPEN the SERVICE STOPS (hot & cold) to flush out the supply lines.

CAUTION: FAILURE TO FLUSH THE SUPPLY LINES WILL PERMANENTLY DAMAGE THE CARTRIDGE AND VOID THE WARRANTY! REPEAT THE FLUSHING PROCESS AS NEEDED BEFORE FINAL TRIM INSTALLATION!

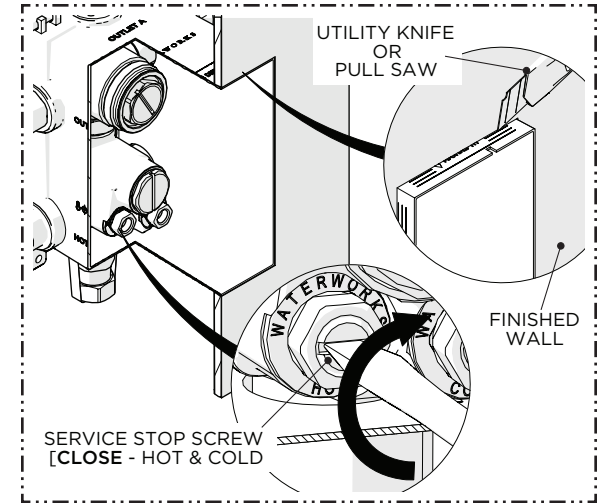

2. After the lines have been fully flushed, CLOSE the SERVICE STOPS (hot & cold) then, using a utility knife or pull saw, cut the ViaBox™ where it protrudes past the finished wall.

NOTE: The ViaBox™ should be flush with the finished wall.

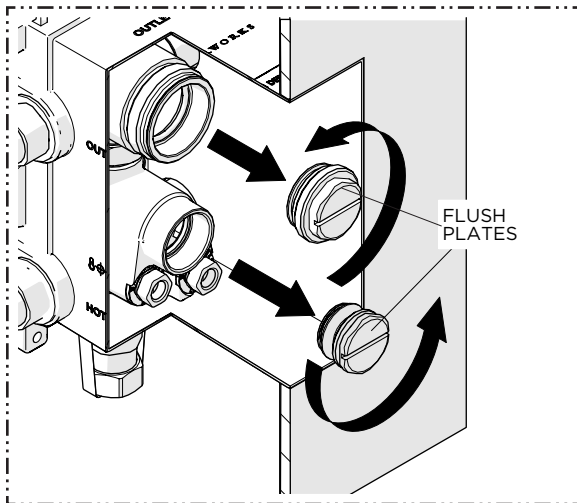

3. Unthread and remove the FLUSH PLATES.
NOTE: Do NOT discard the FLUSH PLATES.

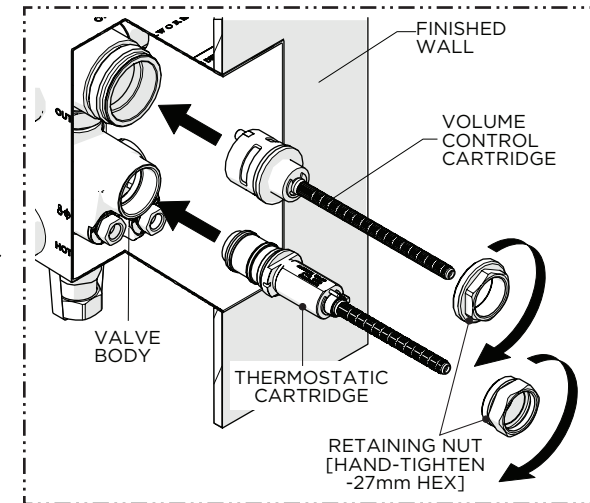

4. Insert the THERMOSTATIC CARTRIDGE and VOLUME CONTROL CARTRIDGE into the VALVE BODY then thread and **hand-tighten** the RETAINING NUTS into the VALVE BODY.

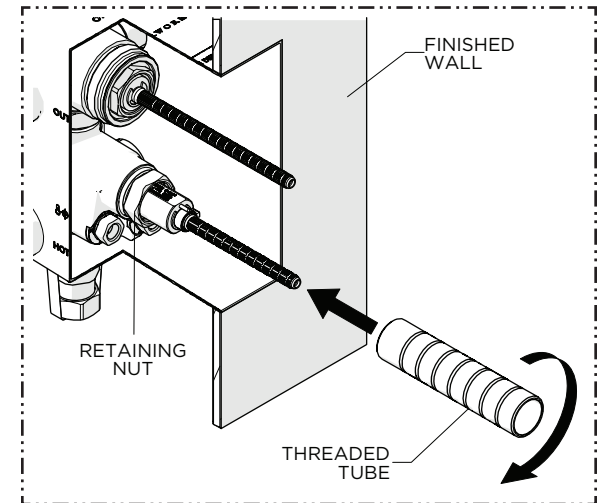

5. Thread the THREADED TUBE into the THERMOSTATIC RETAINING NUT until snug.

INSTALLATION GUIDELINES

INTEGRATED THERMOSTATIC

WATERWORKS

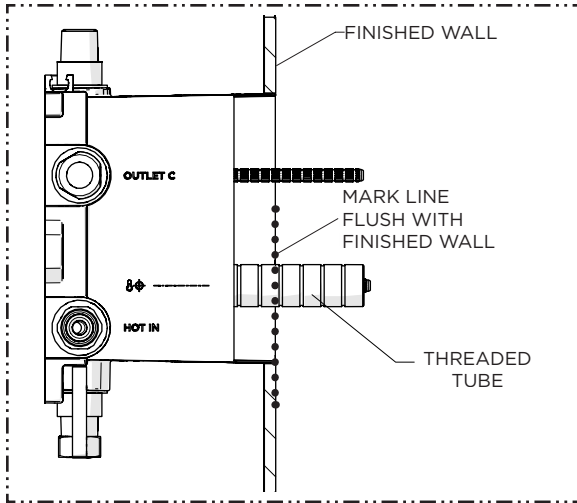

6. Mark the THREADED TUBE where it protrudes past the finished wall.

NOTE: A straight edge (not supplied) can be used to mark the THREADED TUBE.

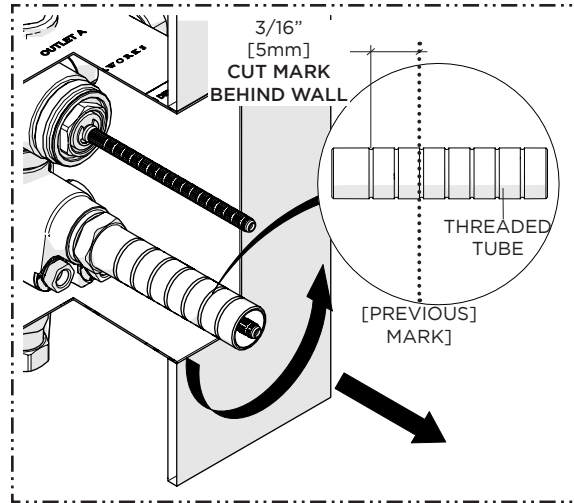

7. Remove the TUBE and cut it 3/16" [5mm] behind the previous mark so the TUBE will recess 3/16" [5mm] into the finished wall surface.

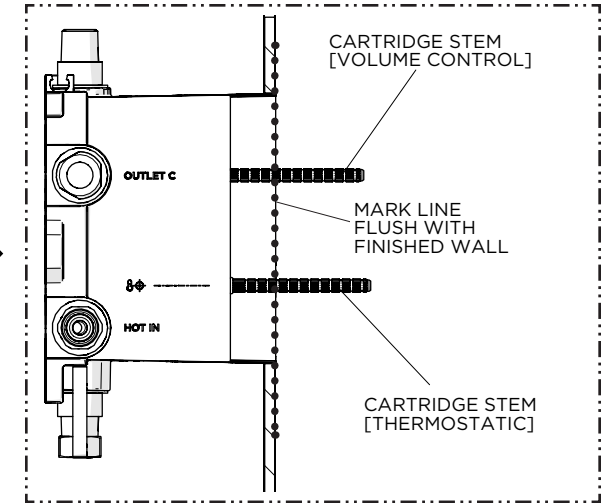

8. Mark both CARTRIDGE STEMS where they protrude past the finished wall.

NOTE: A straight edge (not supplied) can be used to mark the CARTRIDGE STEMS.

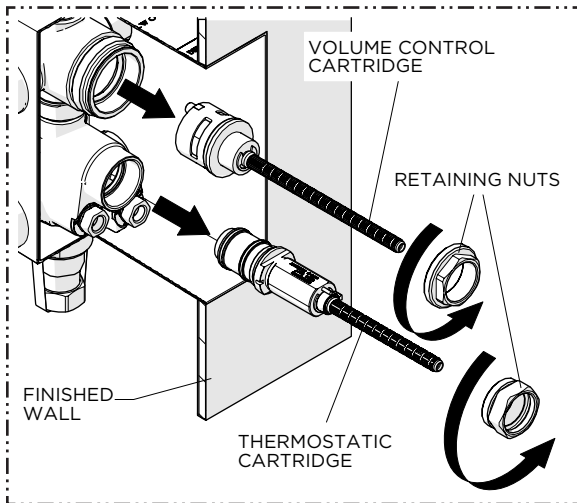

9. Unthread both RETAINING NUTS and remove both CARTRIDGES.

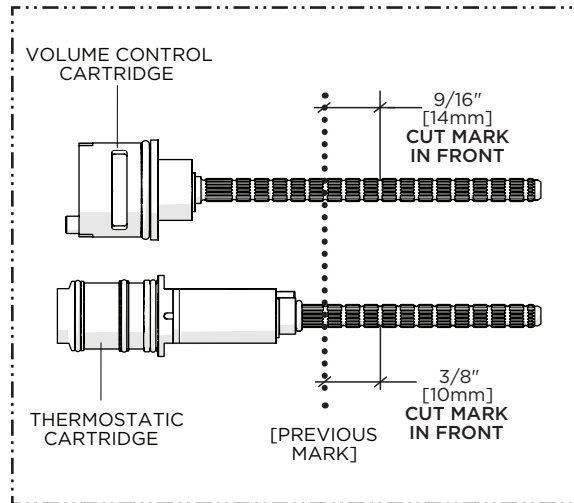

10. Carefully cut the VOLUME CONTROL STEM 9/16" [14mm] in front of the previous mark and THERMOSTATIC STEM 3/8" [10mm] in front of the previous mark so the STEMS will protrude 9/16" [14mm] and 3/8" [10mm] from the finished wall surface respectively.

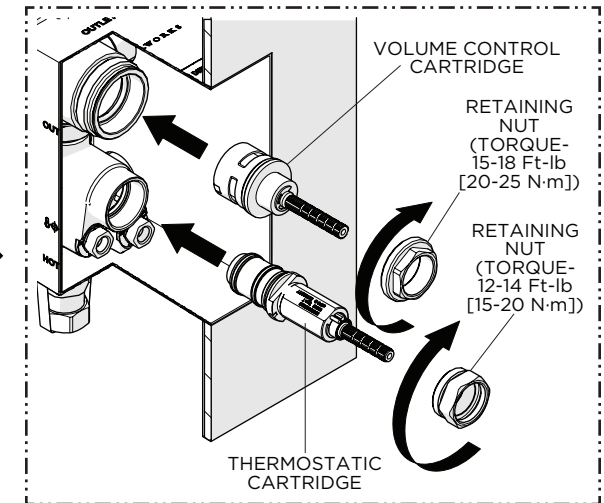

11. Insert both CARTRIDGES back into the VALVE BODY then thread and **securely** tighten the RETAINING NUTS to the specified torque settings shown.

INSTALLATION GUIDELINES

INTEGRATED THERMOSTATIC

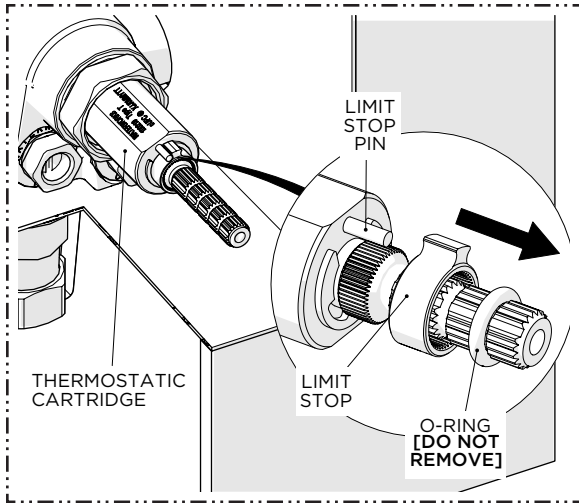

12. Slide the O-RING and LIMIT STOP on the THERMOSTATIC CARTRIDGE up the STEM.

NOTE: Do **NOT** remove or damage the O-RING.

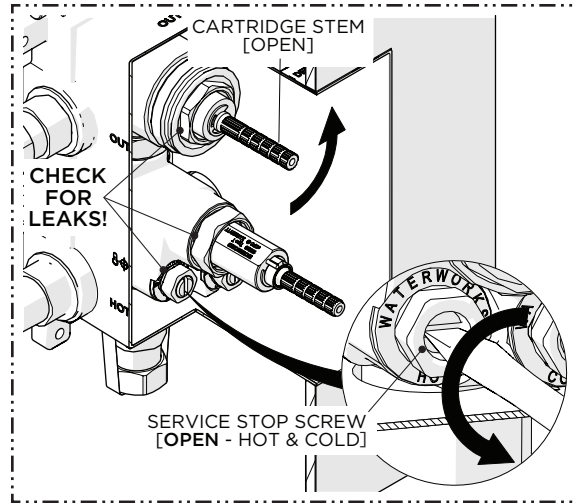

13. **OPEN** both SERVICE STOPS (hot & cold) and check for leaks.

If no leaks are found, turn the CARTRIDGE STEM counterclockwise to open the integrated VOLUME CONTROL VALVE.

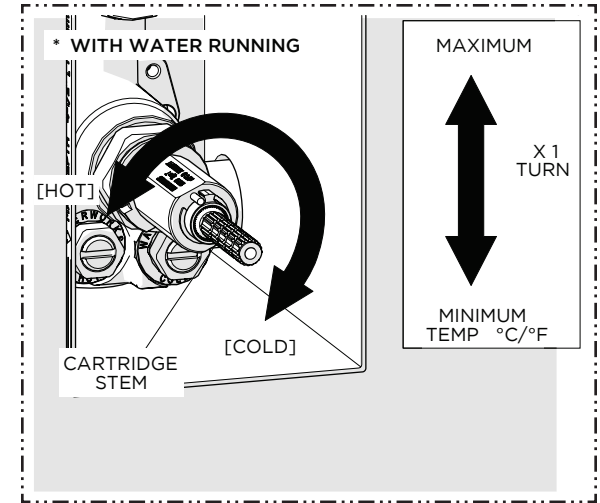

14. With water running, slowly rotate the THERMOSTATIC CARTRIDGE STEM clockwise to attain full cold then rotate it counterclockwise to attain full hot. Verify that a full range of temperatures exists.

NOTE: It's approximately 1 complete rotation.

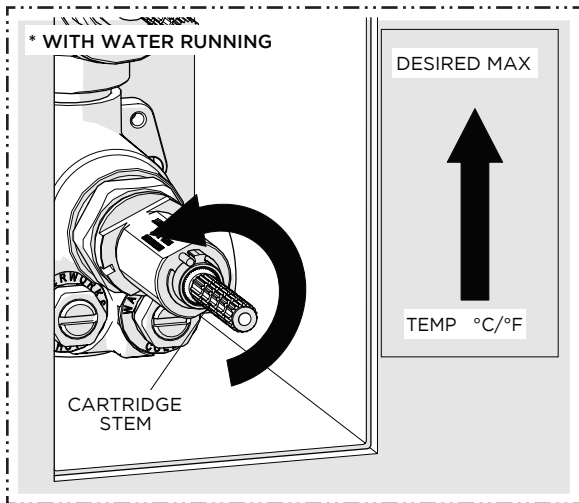

15. Rotate the THERMOSTATIC CARTRIDGE STEM to adjust the temperature to the **maximum** desired bathing temperature, verified with a thermometer, then close the VOLUME CONTROL VALVE and make sure **NOT** to change this setting.

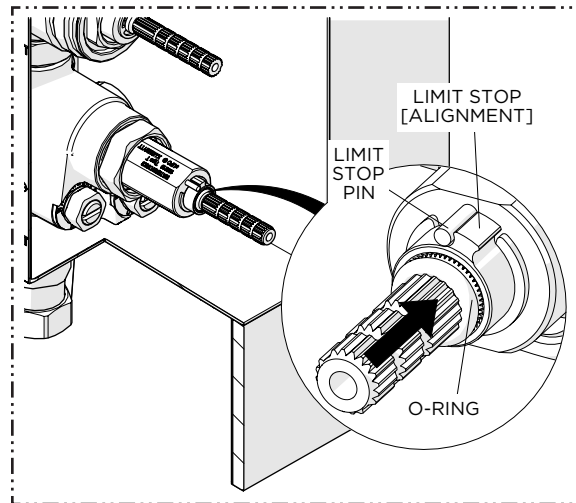

16. Slide the LIMIT STOP and O-RING back down the STEM making sure to properly align the LIMIT STOP with the LIMIT STOP PIN.

NOTE: The O-RING will prevent the LIMIT STOP from sliding off the STEM.

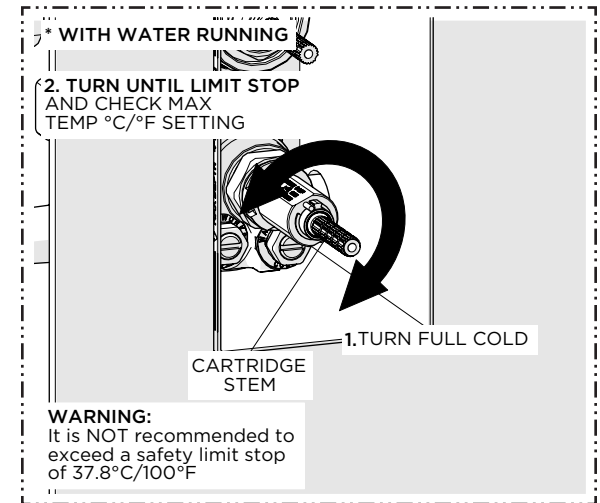

17. Re-open the VOLUME CONTROL VALVE then turn the THERMOSTATIC CARTRIDGE STEM clockwise to full cold then counterclockwise until it stops. Verify the **maximum** desired bathing temperature set in the previous step then turn the water off.

WARNING: It is **NOT** recommended to exceed a safety limit stop of 37.8°C/100°F.

INSTALLATION GUIDELINES

INTEGRATED THERMOSTATIC

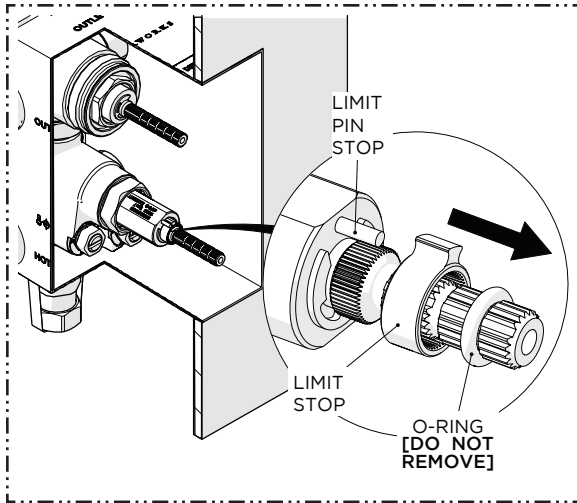

IF THE MAXIMUM BATHING TEMPERATURE IS NOT CORRECT OR NEEDS TO BE ADJUSTED:

- Slide the O-RING and LIMIT STOP back up the STEM to disengage and **REPEAT** steps 14 through 17 to re-calibrate the temperature setting.

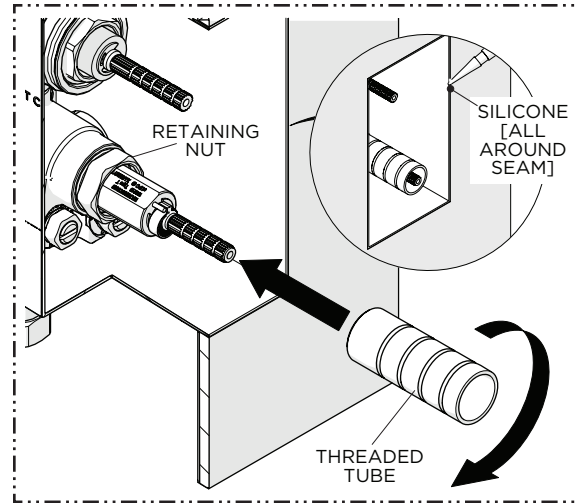
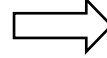

- Thread the THREADED TUBE back into the RETAINING NUT until snug.

NOTE: Add a bead of SILICONE where the ViaBox™ contacts the finished wall.

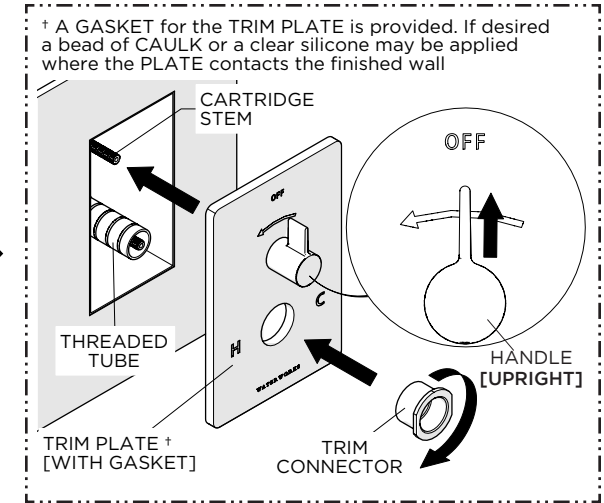
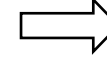

- With the VOLUME CONTROL HANDLE in an upright vertical position, align the HANDLE with the CARTRIDGE STEM then thread and securely tighten the TRIM CONNECTOR onto the THREADED TUBE.

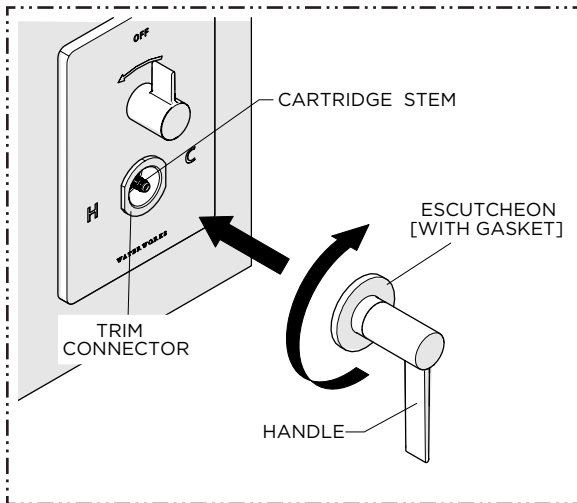

- With the HANDLE in the desired orientation, place the HANDLE over the CARTRIDGE STEM then thread and securely tighten the ESCUTCHEON into the TRIM CONNECTOR.

Operate both HANDLES to ensure they function properly.