

INSTALLATION GUIDELINES

PRESSURE BALANCE CONTROL VALVE TRIM

DASH PRESSURE BALANCE CONTROL VALVE TRIM WITH METAL LEVER HANDLE

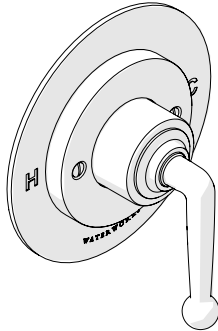

STYLE
DSPB10

IMPORTANT:

- To ensure this product is installed properly, you must read and follow these guidelines.
- The owner/user of this product must keep this information for future reference.
- This product is intended to work with the Waterworks Viaworks Pressure Balance Valve (Style No. **GUPB01**). The VALVE controls on/off and mixes hot and cold water but can also be paired with a Waterworks Viaworks Two Way (Style No. **GUDV2P**) or Three Way (Style No. **GUDV3P**) Diverter Valve. **ALL VALVES AND TRIMS SOLD SEPARATELY.**
- **WARNING:** The risk of scalding exists until the installer has properly calibrated/adjusted the temperature setting during final trim installation.
- This product must be installed by a professional licensed contractor and must be on-site prior to rough-in, this allows the installer to visualize the installation.
- Be sure your installation conforms to federal, state, and local codes. In the State of Massachusetts, all installations must comply with the rules and regulations set forth within 248 CMR.
- The bottom outlet of the **GUPB01** is intended for use with a diverting tub spout only,
- Do **NOT** use Pex piping from the VALVE to the tub spout. It will create too much back pressure and cause the VALVE to malfunction.
- Inspect this product to ensure you have all the parts required for proper installation. Product is **sold partially** assembled but shown fully disassembled for illustrative and service purposes only.

- Use only a strap wrench or protected/smooth-jaw wrench on any finished surface.
- The use of certain plumber's putty may stain stone or tile surfaces.
- If further assistance is required, please contact Product Support at 1-800-927-2120 Monday through Friday, 8am - 6pm EST.
- Refer to the separate Service Parts Documents for available replacement parts.

CARE AND MAINTENANCE:

- If this product will remain unused for an extended period of time (over 3 months), then the water to the VALVE should be shut off (via service stops or system control valve) and the VALVE should be opened to allow the water in the VALVE to evaporate. This to keep the PISTON in the CARTRIDGE from sticking, due to stagnant or hard water, once the VALVE is in use again. If the piston does stick, soak the CARTRIDGE in household vinegar. Refer to the Installation Guidelines for the **GUPB01** for maintenance instructions, complete parts breakdown and related information.
- **WINTERIZE:** If this product will remain unused during the WINTER months then the water to the VALVE should be shut off (via service stops or system control valve) and the CARTRIDGE should be removed and replaced with the FLUSH PLATE. Refer to the Installation Guidelines for the **GUPB01** for instructions on how to properly remove and re-install the CARTRIDGE.

VALVE FUNCTION:

- The VALVE controls on/off and temperature. The handle rotates counter-clockwise through the cold, the warm, then the hot positions.
- **ALL VALVES AND TRIMS SOLD SEPARATELY.**

REQUIRED PLUMBING DETAILS:

- Viaworks 1/2" Pressure Balance Valve
- **STYLE No.** GUPB01

TECHNICAL DETAILS:

DETAIL	SPECIFICATION
INLET CONNECTIONS	1/2" MALE NPT+ / 1/2" COPPER SWEAT
OUTLET CONNECTIONS	
ROUGH-IN DEPTH	2-7/8" [74 mm] MAXIMUM 1-7/8" [49 mm] MINIMUM
WATER PRESSURE	85psi [6.0 bar] MAXIMUM
	20psi [1.5 bar] MINIMUM
	45psi [3.0 bar] RECOMMENDED

INSTALLATION GUIDELINES

PRESSURE BALANCE CONTROL VALVE TRIM

ROUGH-IN AND VALVE PREPARATION:

- Refer to the Installation Guidelines provided with each VALVE for complete rough-in installation details and related information.
- **CAUTION:** The rough-in depth is measured from the centerline of the inlets to the surface of the finished wall. If the VALVES are roughed-in too shallow, the associated TRIMS cannot be installed correctly.
- The DIVERTER VALVE can ONLY be connected to the top outlet port of the PRESSURE BALANCE VALVE.
- Do **NOT** use:
 - The bottom (tub) outlet port of the PRESSURE BALANCE VALVE for any fittings with restricted flow, such as a handshower or body spray. The back pressure created would cause water to flow out through the top (shower)
 - PEX piping from the VALVE to the tub spout. It will create too much back pressure and cause the VALVE to malfunction.
 - A shut-off device on either side of the PRESSURE BALANCE VALVE. The installation of any such device may create a cross-flow condition at the VALVE and affect water temperature.
- **IMPORTANT:** Make sure the supply lines are flushed prior to final TRIM installation using the FLUSH PLATE provided with the PRESSURE BALANCE VALVE.
- Remove and discard the TILE GUARDS only when the finished wall surface (TILE or SLAB) is completed and TRIMS are ready for installation.

VALVE	DIMENSION	VALUE
GUPB01	A	2-7/8" [74 mm] MAXIMUM 1-7/8" [49 mm] MINIMUM
	B	Ø3-1/2" [89 mm]

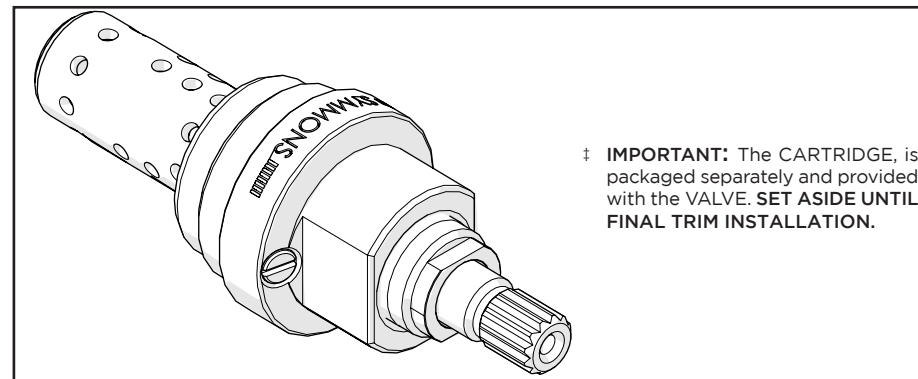
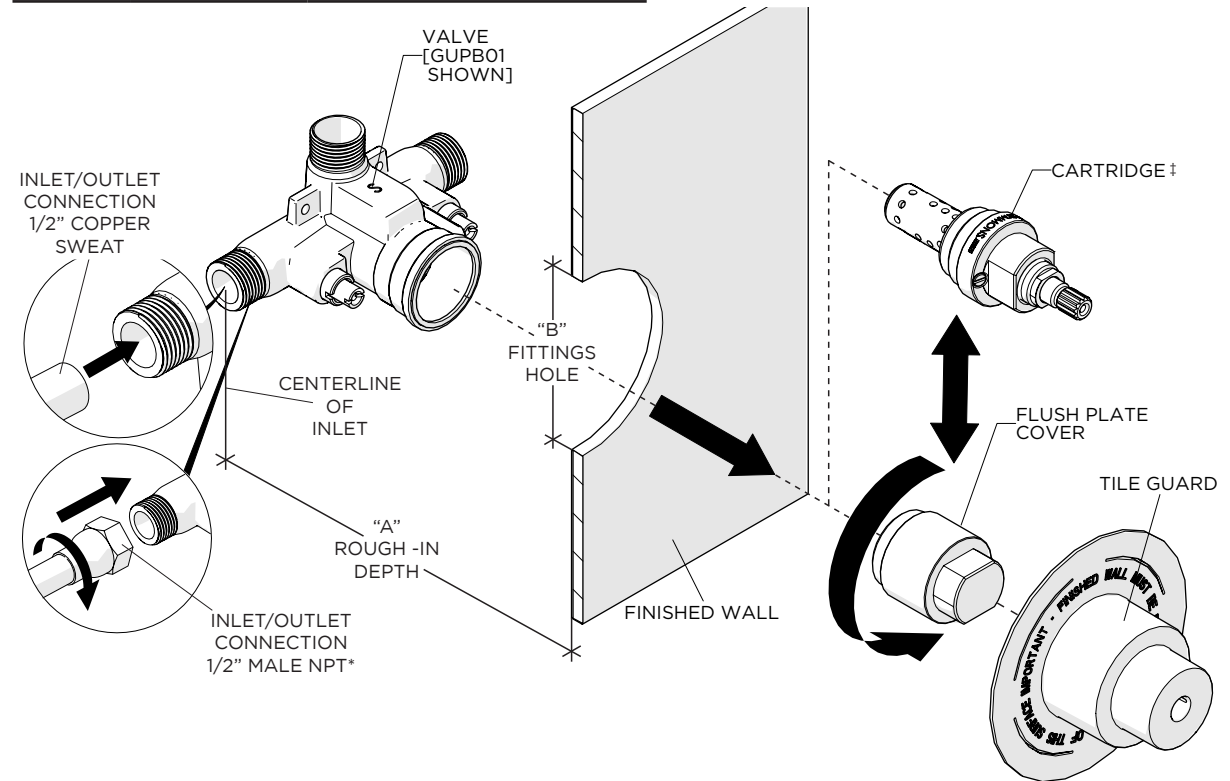

‡ **IMPORTANT:** The CARTRIDGE, is packaged separately and provided with the VALVE. **SET ASIDE UNTIL FINAL TRIM INSTALLATION.**

INSTALLATION GUIDELINES

PRESSURE BALANCE CONTROL VALVE TRIM

WATERWORKS

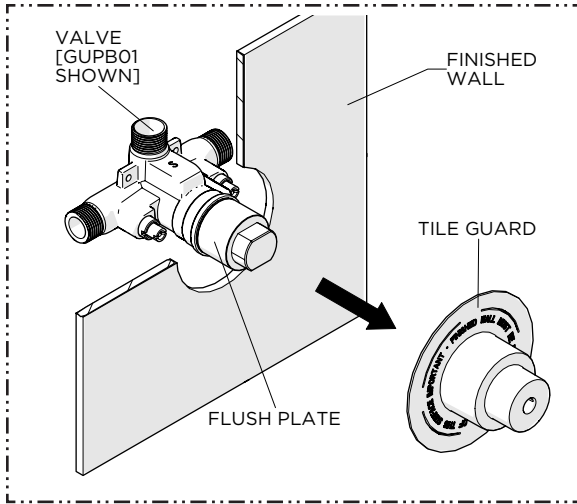

1. Remove the TILE GUARD from the VALVE when the TRIM is ready to be installed.

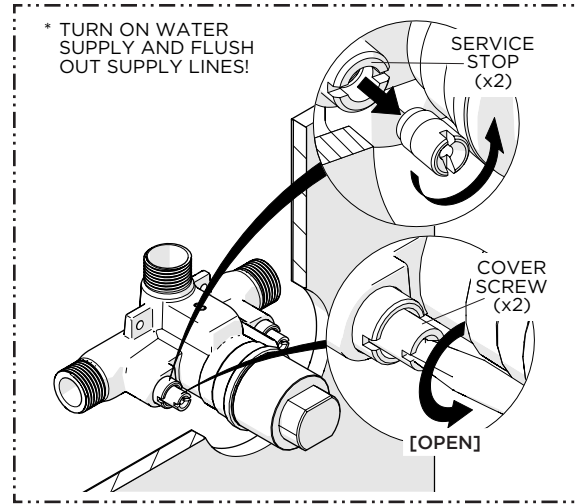

2. Turn on the water supplies then remove the COVER SCREWS (x2) and OPEN the SERVICE STOPS (x2) (hot & cold) to flush out the supply lines.

CAUTION: FAILURE TO FLUSH THE SUPPLY LINES WILL PERMANENTLY DAMAGE THE CARTRIDGE AND VOID THE WARRANTY! REPEAT THE FLUSHING PROCESS AS NEEDED BEFORE FINAL TRIM INSTALLATION.

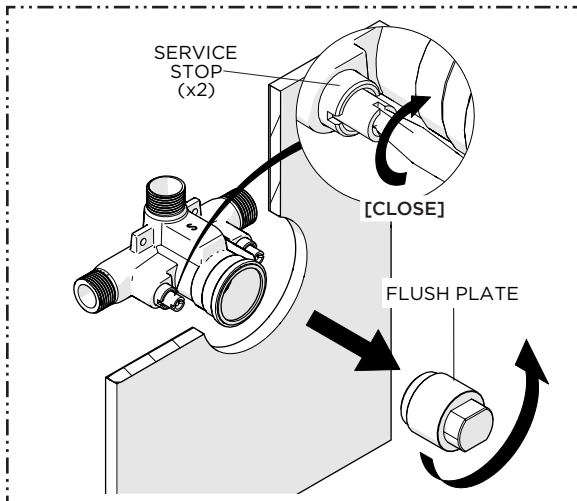

3. After the lines have been fully flushed, CLOSE the SERVICE STOPS (hot & cold) then unthread and remove the FLUSH PLATE.

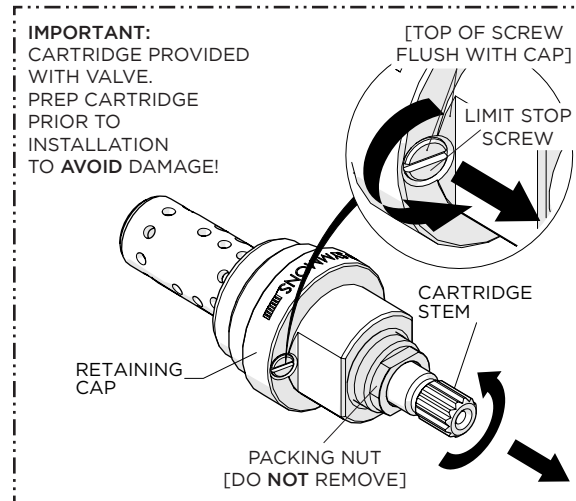

4. **IMPORTANT:** Leaving the PACKING NUT in place, unthread the LIMIT STOP SCREW until the O-RING is fully exposed then rotate the CARTRIDGE STEM counterclockwise to ensure the CARTRIDGE is drawn as close as possible to the RETAINING CAP.

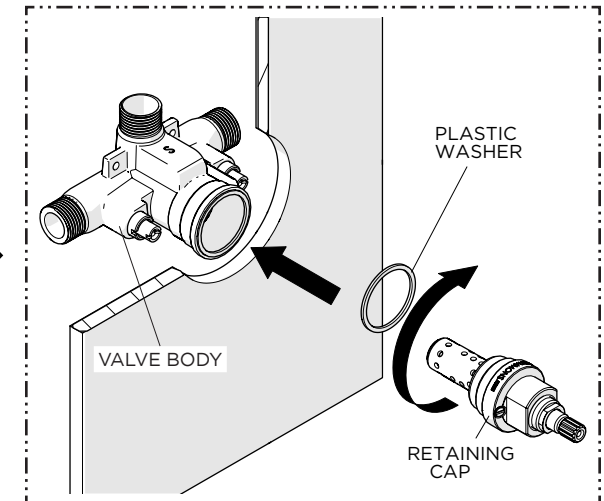

5. Using the PLASTIC WASHER provided, insert the CARTRIDGE into the VALVE then thread and securely tighten the RETAINING CAP.

NOTE: The CARTRIDGE controls on/off and temperature only, **not** volume.

INSTALLATION GUIDELINES

PRESSURE BALANCE CONTROL VALVE TRIM

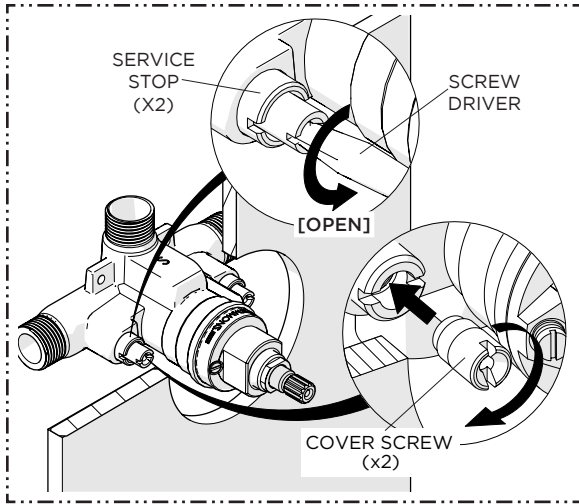

6. OPEN the SERVICE STOPS (X2) (hot & cold) then reinstall the COVER SCREWS (x2).

NOTE: The VALVE will **not** operate unless both hot and cold supplies are turned on.

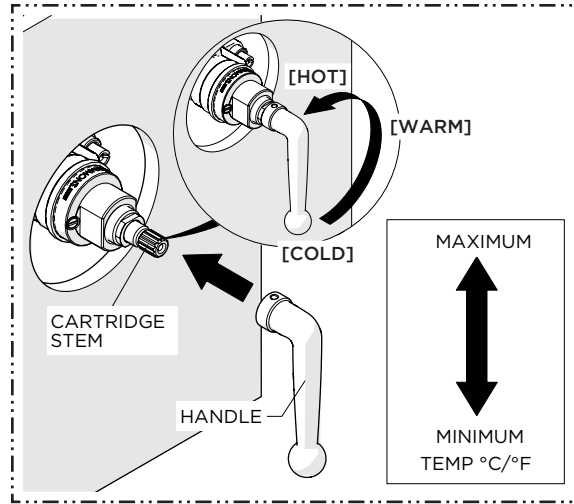

7. With the VALVE off, place the HANDLE on the CARTRIDGE STEM in the 6 o'clock position then turn the HANDLE counterclockwise through the cold, warm, and stopping at the hot position.

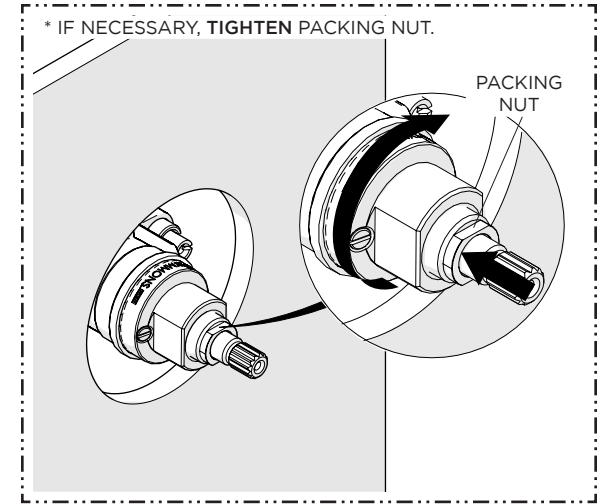

8. The PACKING NUT needs to be securely tightened to prevent a water leak from the CARTRIDGE STEM and create adequate rotational friction to maintain HANDLE position.

NOTE: The HANDLE is for controlling on/off and temperature only, **not** volume.

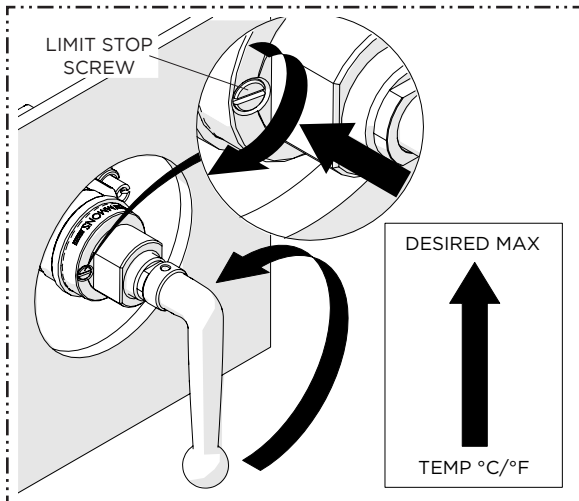

9. Open the VALVE to the **maximum** desired bathing temperature verified with a thermometer then turn the LIMIT STOP SCREW clockwise until it seats. Turn the VALVE off then on and verify the temperature.

WARNING: It is **NOT** recommended to exceed a safety limit stop of **37.8°C/100°F**

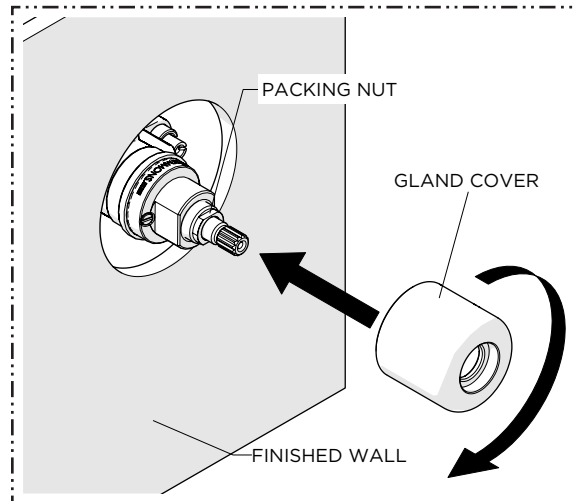

10. Thread and securely tighten the GLAND COVER onto the VALVE.

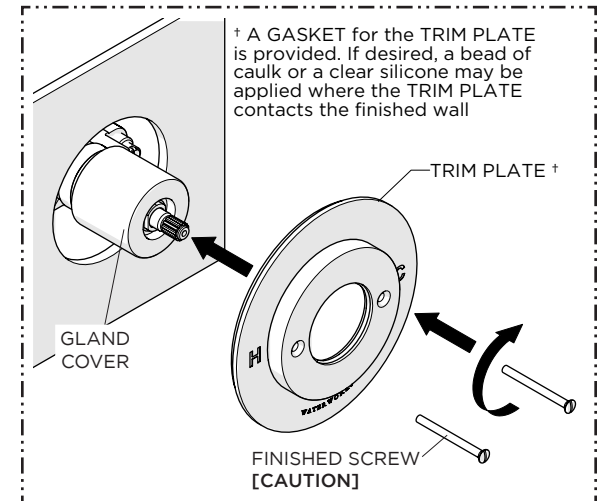

11. Slide the TRIM PLATE over the GLAND COVER then thread and securely tighten the SCREWS (X2).

INSTALLATION GUIDELINES

PRESSURE BALANCE CONTROL VALVE TRIM

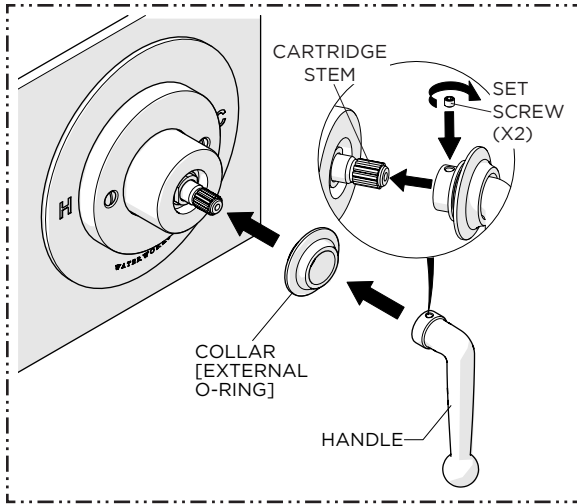

12. Slide the COLLAR and the O-RING over the base of the HANDLE then attach the HANDLE to the CARTRIDGE STEM and tighten the SET SCREWS (X2).

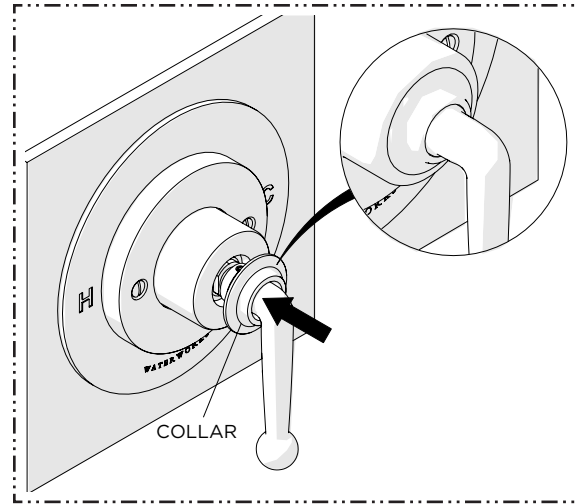
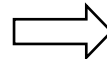

13. Slide the COLLAR against the GLAND COVER to conceal the SET SCREWS. The O-RING will hold the COLLAR in place.

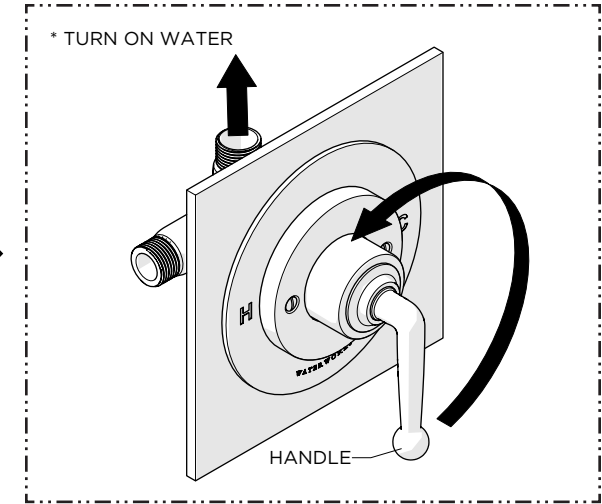
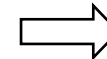

14. Turn on the water and operate the HANDLES to ensure it is functioning properly.

TROUBLESHOOTING

1. VALVE will **not** flow water.

- **CAUSE:** Hot and cold water **not** turned on or SERVICE STOPS **not** opened.
- **SOLUTION:** Be sure both supplies are turned on and both SERVICE STOPS are open. The VALVE will **not** operate unless both hot and cold water inlets have pressure.

2. VALVE leaks when shut-off.

- **CAUSE:** Hot and cold water WASHERS are worn or foreign matter (solder, chips, etc.) are between WASHERS and SEAT surfaces.
- **SOLUTION:** Replace hot and cold washers and inspect top surface on hot and cold seats for damage. Refer to the Installation Guidelines provided with the VALVE for more details.

3. VALVE makes loud noise.

- **CAUSE:** PISTON in CARTRIDGE is moving back and forth because of a large pressure differential between hot and cold water lines.
- **SOLUTION:** Alter the water system such that the pressure differential at all shower valves is no more than 5 psi (0.3 Bar).

4. Temperature out of VALVE reduces gradually during use.

- **CAUSE:** Supply system is running out of hot water.
- **SOLUTION:** Reduce **maximum** flow rate out of VALVE or showerhead. This will allow longer period of use before reduction of hot water supply.

5. Water volume from VALVE is inconsistent during operation, VALVE delivers an insufficient quantity of hot and cold water, or temperature fluctuates without moving temperature HANDLE.

- **CAUSE:** CONTROL PISTON housed in the CARTRIDGE is blocked from free movement by foreign matter.
- **SOLUTION:** With VALVE open half way, remove the temperature control HANDLE and tap the CARTRIDGE STEM with a plastic hammer. If problem is **not** solved refer to the Installation Guidelines provided with the VALVE to properly remove the CARTRIDGE then tap the handle end of the CARTRIDGE against a solid object to free the piston and rinse the CARTRIDGE. Soaking in house-hold vinegar will help free debris build up.

6. Outlet water temperature, in the full hot position, from the VALVE is lower than inlet water temperature or lower than another fitting such as a faucet in the same room, opened to full hot.

- **CAUSE:** This is a design function of the VALVE. The VALVE will always allow some cold water through in the full hot position. The difference from the inlet to outlet temperature is related to the pressure balance between the hot and cold supplies. The more the pressures are imbalanced the more the temperatures will vary.
- **SOLUTION:** If a hotter outlet water temperature is needed, the inlet water temperature must be adjusted. Refer to the Installation Guidelines provided with the VALVE for more details.