

Metal Wheel Handle
STYLE No. RWXS01

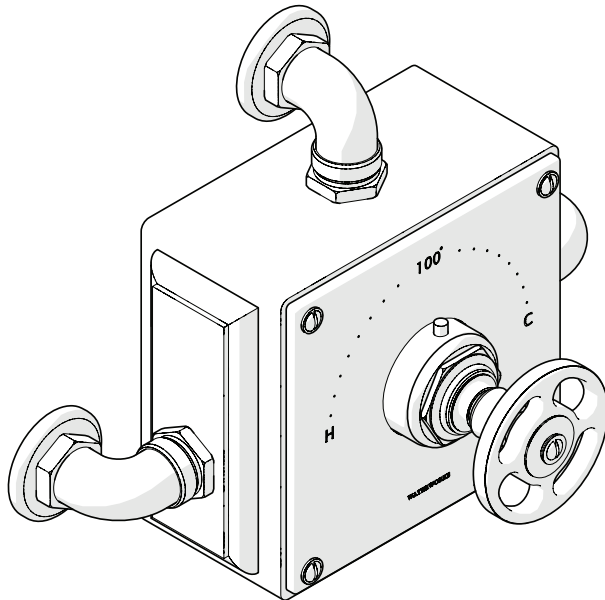

Metal Lever Handle
STYLE No. RWXS10

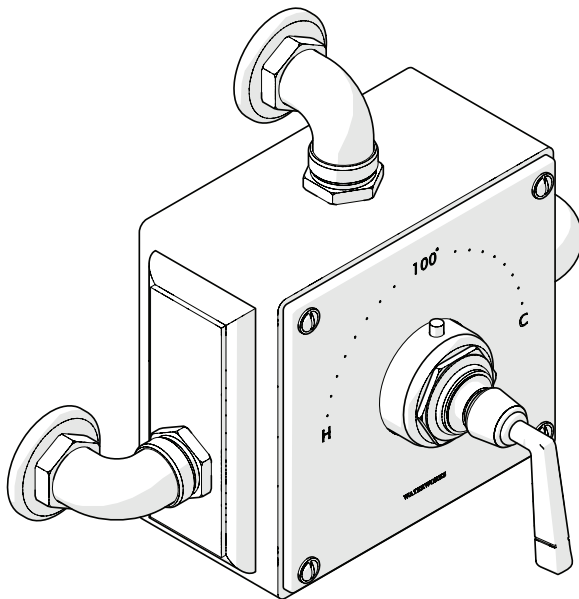

SPECIFICATIONS:

Connection Type: 3/4" Copper Compression
Inlet Spread: 11-1/2" **MIN** - 11-3/4" **MAX**
Outlet Spread (From Inlets): 5-7/8" **MIN** - 6" **MAX**
Recommended Pressure: 45 psi

IMPORTANT:

- To ensure this product is installed properly, you must read and follow these guidelines.
- The owner/user of this product must keep this information for future reference.
- This product is supplied with the Waterworks Universal Thermostatic Valve (**STYLE No. GUTH37**) which features anti-scald protection. The risk of scalding exists until the installer has properly calibrated/adjusted the temperature setting during final trim installation. Refer to the Installation Guidelines of the thermostatic valve for additional information.
- Be sure your installation conforms to federal state, and local codes. In the State of Massachusetts, all installations must comply with the rules and regulations set forth within 248 CMR.
- **This exposed thermostatic valve only mixes hot and cold water. It does not have volume control or shutoff capabilities. A diverter or wall valve (sold separately) control on/off/volume and must be installed for each fitting that will have water flowing to it. This valve cannot be used directly with a diverting tub spout.**
- This product must be installed by a professional licensed contractor and must be onsite prior to rough-in, this allows the installer to visualize the installation.
- Proper blocking in the wall is required.
- Inspect this product to ensure you have all the parts required for proper installation.
- Use only a strap wrench or protected/smooth-jaw wrench on any finished surface.
- Install accessible **hot** and **cold** service stop valves to facilitate servicing.
- **DO NOT** use putty on fittings.

These guidelines have been prepared for the professional contractor to aid in the installation of:
RW ATLAS EXPOSED THERMOSTATIC VALVE WITH METAL WHEEL HANDLE (STYLE No. RWXS01)
& METAL LEVER HANDLE (STYLE No. RWXS10)
All dimensions are based on original specification and are subject to change and variation.
PLEASE CONSULT YOUR DESIGN ASSOCIATE FOR CURRENT SPECIFICATIONS.
SEE SERVICE PART DOCUMENT FOR PART ORDERING, AVAILABLE ON WATERWORKS.COM

WATERWORKS

ROUGH IN:

- See Figure - 01 for Steps 1-4.
- 1. Run well supported 3/4" **hot** and **cold** copper SUPPLY LINES for **maximum** flow.
- 2. Determine the ideal location of the valve, based on user preferences. Install blocking to properly secure the valve body.
- 3. Verify the supplies and outlet are secure and level. The inlets must have a spread of 11-1/2" **MIN** to 11- 3/4" **MAX**. The outlet must be 5-7/8" **MIN** to 6" **MAX** vertically from the inlets and centered horizontally between the two inlets. Make sure the **hot** supply is on the left and the **cold** supply is on the right. Cap off supplies and outlet and check for **leaks**.
- 4. Cut the copper lines so they extend 15/16" from the finished wall.

FIGURE - 01

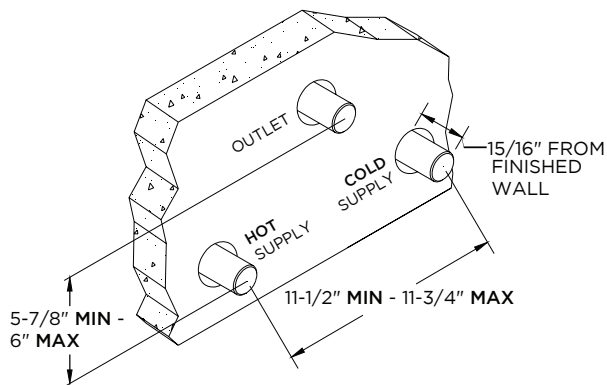

EXPOSED VALVE INSTALLATION:

- See Figure - 02 for Steps 5-13.
- 5. Unthread and remove the compression nuts and compression rings, along with escutcheons and orings from each elbow.
- 6. Slide the o-ring, escutcheon, compression nut and compression ring over each connection tube, making sure the threading on the compression nut is facing outwards.
- 7. Loosen the knurled collars and thread the elbows into the valve body until they stop, then un-thread enough so that they align with the supply tubes and outlet tube (**MAXIMUM 3 ROTATIONS**). Note that the elbow seal is created by internal o-rings and **NOT** by fully tightening the elbow.
- 8. Position the valve body assembly onto the supplies and outlet until they are fully seated into the elbow and then hand tighten the compression nuts. Slide the escutcheon back towards the wall, and if the gap is too large, as to where the escutcheon slides off the compression nut, cut the supply and outlet tubes accordingly.
- 9. With the valve level and up against the wall, mark the 4 mounting hole locations through the holes that are on the back plate of the valve body.

- 10. Loosen the compression nuts and remove the valve body.
- 11. Drill the wall for the 4 wall anchors provided and install them.
- 12. Re-install the valve onto the supply and outlet tubes, then , using a wrench, tighten the compression nuts fully. Tighten the knurled collars so that they are tight against the side of the valve body. Make sure the escutcheons are against the wall, with the o-ring behind it.
- 13. Install the screws, through the valve body and into the wall anchors to fully secure the assembly.

FIGURE - 02

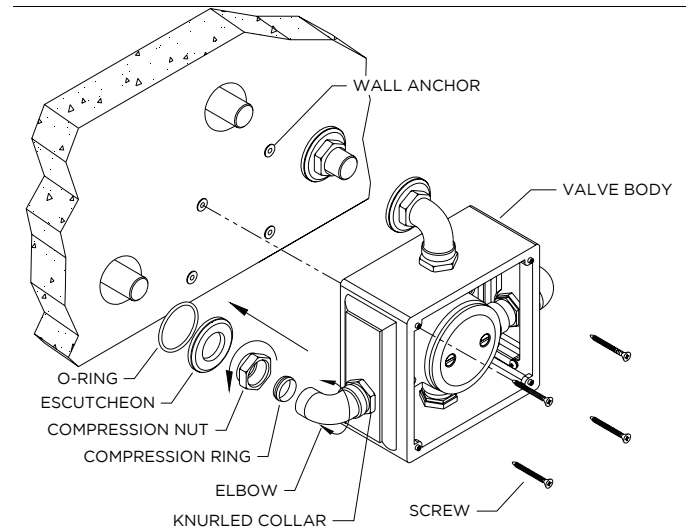

FLUSH OUT THE SYSTEM:

- Wall valves and/or diverters and all shower fittings, must be fully plumbed and installed prior to flushing the system. (ALL SOLD SEPARATELY).
- The SUPPLY LINES must be flushed out to prevent clogging of the filter screens. Failure to flush the lines will permanently damage the cartridge and void the warranty.
- See Figure - 03 for Steps 14-18.
- 14. The exposed wall valve comes pre-installed with the flush plate and is ready for flushing the lines.
- 15. Remove the showerhead and/or handshower (any fitting with a flow regulator).
- 16. Turn on the water supply to flush out the lines, then inspect all connections for **leaks**.
- 17. After the lines are flushed, turn off the water supply and remove the flush plate.
- 18. Install the cartridge using the 2 cover screws and turn the service stops off.

These guidelines have been prepared for the professional contractor to aid in the installation of:
RW ATLAS EXPOSED THERMOSTATIC VALVE WITH METAL WHEEL HANDLE (STYLE No. RWXS01)
& METAL LEVER HANDLE (STYLE No. RWXS10)
All dimensions are based on original specification and are subject to change and variation.
PLEASE CONSULT YOUR DESIGN ASSOCIATE FOR CURRENT SPECIFICATIONS.
SEE SERVICE PART DOCUMENT FOR PART ORDERING, AVAILABLE ON WATERWORKS.COM

WATERWORKS

FIGURE - 03

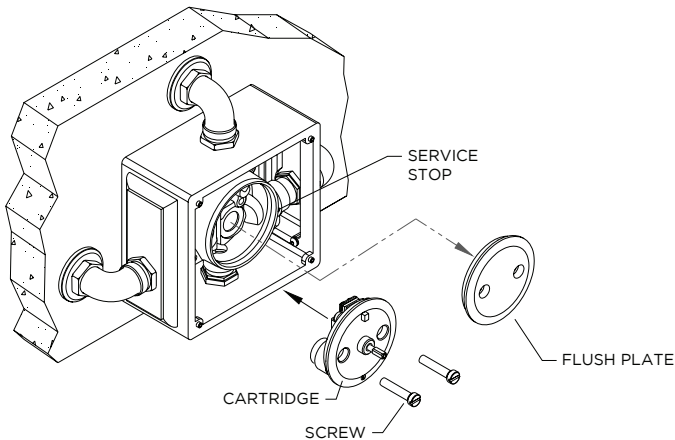

TRIM PLATE INSTALLATION:

- See Figure - 04 for steps 19 - 21.
- 19. Attach trim plate to valve body using the 4 screws, making sure the gasket is behind the plate.
 - Note:** USE A LARGE SLOTTED SCREWDRIVER TO AVOID DAMAGING SCREWS.
- 20. Thread the all thread adapter onto the cartridge until it stops and insert the square tube over the cartridge stem.
- 21. Thread the trim nut onto the all thread adapter until it stops.
 - Note:** DO NOT OVER-TIGHTEN.

FIGURE - 04

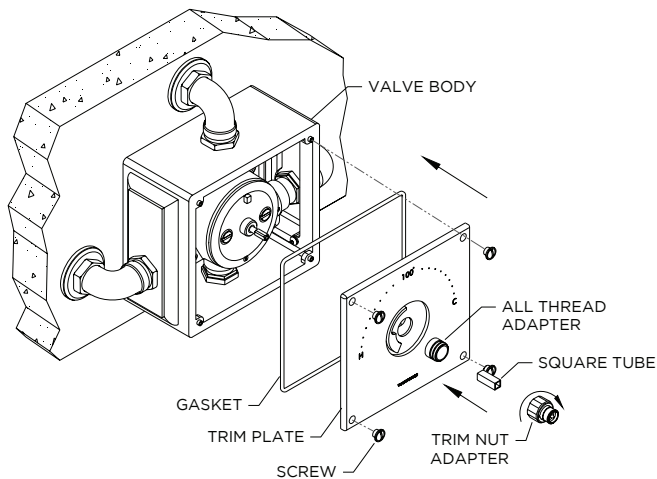

TEMPERATURE CALIBRATION:

- The risk of scalding exists until the installer has properly calibrated the temperature setting.
- See Figure - 05 for steps 22 - 26.
- 22. Turn on the water supply and a wall valve to run water through the valve and insert a bladed screw driver into the square tube.

23. Slowly rotate the square tube clockwise to attain full cold, then rotate it counter-clockwise to attain full hot. Verify a full range of temperature exists.

Note: It is approximately 2 complete rotations from full cold to full hot.

24. With water running, rotate the square tube to adjust the temperature to the **maximum** desired bathing temperature, verified with a thermometer. Turn the water off and make sure **not** to change this temperature setting.
25. Unthread the handle assembly from the limit stop assembly and loosen the 4 set screws on the limit stop.
26. Insert the limit stop assembly onto the trim nut making sure the limit stop pin (**shown removed**) makes contact with the limit stop on the trim plate, then tighten the 4 set screws.

FIGURE - 05

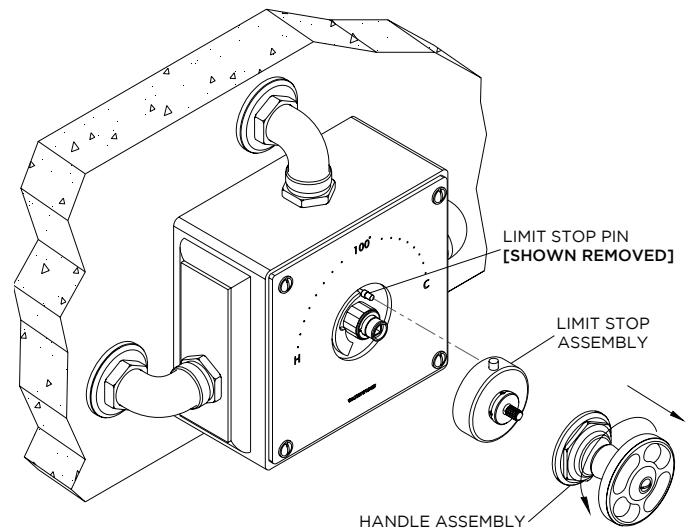

INSPECT THE INSTALLATION:

27. Turn the limit stop clockwise then turn the water on and confirm the limit stop is functioning properly by turning it counter-clockwise at which point it should stop.
28. Verify the temperature to be the **maximum** temperature set in Step 24. If it is **not** the correct temperature, repeat the calibration procedures in Steps 22-26.
29. To get a hotter temperature, press and hold the limit stop button, then rotate the limit stop until it stops. It is **NOT** recommended to **exceed a safety limit stop of 110 degrees**.
30. Re-attach the handle assembly to the limit stop.
 - **If further assistance is required, please contact Product Support at 1-800-927-2120 (8am-6pm EST).**
 - **See service part document for parts ordering, available on WATERWORKS.COM.**

These guidelines have been prepared for the professional contractor to aid in the installation of:
RW ATLAS EXPOSED THERMOSTATIC VALVE WITH METAL WHEEL HANDLE (STYLE No. RWXS01)
& METAL LEVER HANDLE (STYLE No. RWXS10)
All dimensions are based on original specification and are subject to change and variation.
PLEASE CONSULT YOUR DESIGN ASSOCIATE FOR CURRENT SPECIFICATIONS.
SEE SERVICE PART DOCUMENT FOR PART ORDERING, AVAILABLE ON WATERWORKS.COM

WATERWORKS