

STYLE No. FLXT70
with Metal Lever Handles

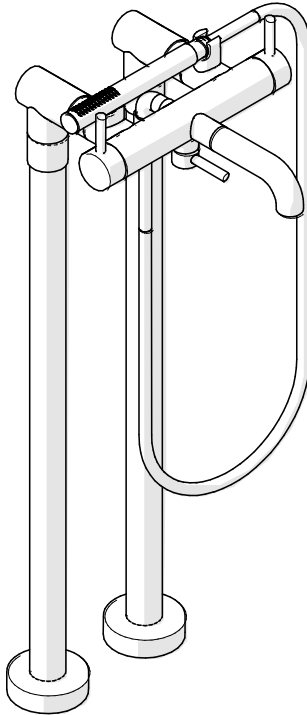

SPECIFICATIONS:

Adjustable versus Fixed Spray: Fixed Spray
Handle Spread (NOT ADJUSTABLE): 10-7/16"
Handshower Hose Length: 59"
Fittings Hole Diameter: Ø1-3/8"
Inlet Connection: 3/4" Copper Sweat
Inlet Spread (NOT ADJUSTABLE): 5-7/8"
Integrated Diverter: Yes
Restricted Maximum Flow Rate: 2.5gpm [9.5L/min][†]
Spout Outlet Height: 30-1/8"
Spout Reach: 11-7/8"
Spout Swivel: N
Water Pressure Maximum: 85psi [6.0 bar]
Water Pressure Minimum: 20psi [1.5 bar]
Water Pressure Recommended: 45psi [3.0 bar]

[†] Only the HANDSHOWER has a restricted flow rate.

IMPORTANT:

- To ensure this product is installed properly, you must read and follow these guidelines.
- The owner/user of this product must keep this information for future reference.
- Product should be on-site prior to rough-in. This allows the installer to visualize the installation and verify the center spread.
- This product must be installed by a professional licensed contractor.

- Be sure your installation conforms to federal, state, and local codes. Anti-scald protection is the responsibility of the installer and according to applicable codes. In the State of Massachusetts, all installations must comply with the rules and regulations set forth within 248 CMR.
- Refer to the specification and assembly drawings attached. Product is sold partially assembled but shown fully disassembled for illustrative and service purposes only.
- Check tub deck and tub measurements to assure the spout projects far enough into the tub.
- Inspect this product to ensure you have all the parts required for proper installation.
- Use only a strap wrench or protected/smooth-jaw wrench on any finished surface.
- The use of certain plumber's putty may stain stone or tile surfaces.
- Install accessible hot and cold service stop valves to facilitate servicing.
- Run 3/4" [22mm] supply lines for maximum flow.

ROUGH-IN:

1. Run well supported 3/4" [22mm] hot and cold supply lines for maximum water flow. The inlet supply spread is 5-7/8" [150mm] on-center and is not adjustable.
2. Determine the location where the supplies will come up through the floor and install a piece of 2" x 10" on its side to serve as a 10" blocking surface to secure the LEGS to the floor.
3. Drill Ø1-3/8" [35mm] holes in the floor with the proper spread for each supply to pass through.
4. Run 3/4" [22mm] copper supplies up through the finished floor and cap-off each line.

LEG INSTALLATION:

- Verify the 5-7/8" [150mm] inlet supply spread prior to installation.
 - See Figure - 01 for Steps 5 - 9.
5. Slide the MOUNTING PLATE over the COPPER SUPPLY LINE in the desired orientation.
 6. Drill 4 holes to accommodate all the SCREWS that will secure the LEG to the floor.
 7. Secure the PLATE to the floor using 4 UNFINISHED SCREWS provided.

NOTE: Make sure to use the 4 countersunk holes to secure the PLATE.

These guidelines have been prepared for the professional contractor to aid in the installation of:
FLYTE EXPOSED FLOOR MOUNTED TUB FILLER (STYLE No. FLXT70)
All dimensions are based on original specification and are subject to change and variation.
Please consult your Design Associate for current specifications.

WATERWORKS
STUDIO

8. Solder the supply line to the inner diameter of the PLATE for added stability.
9. Repeat Step 5 through 8 to install the second PLATE.

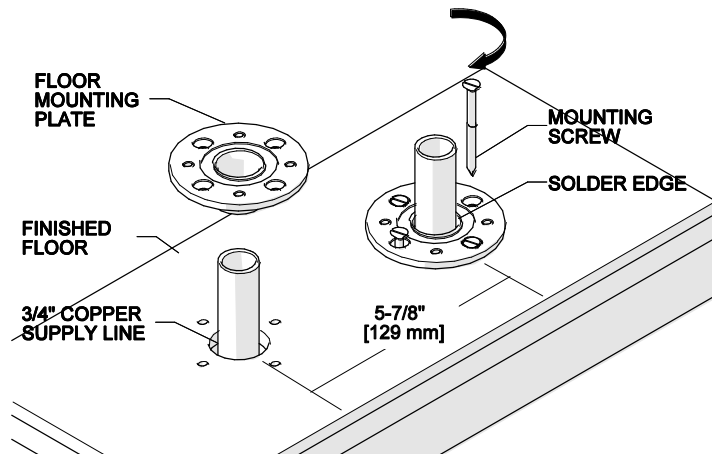

FIGURE - 01

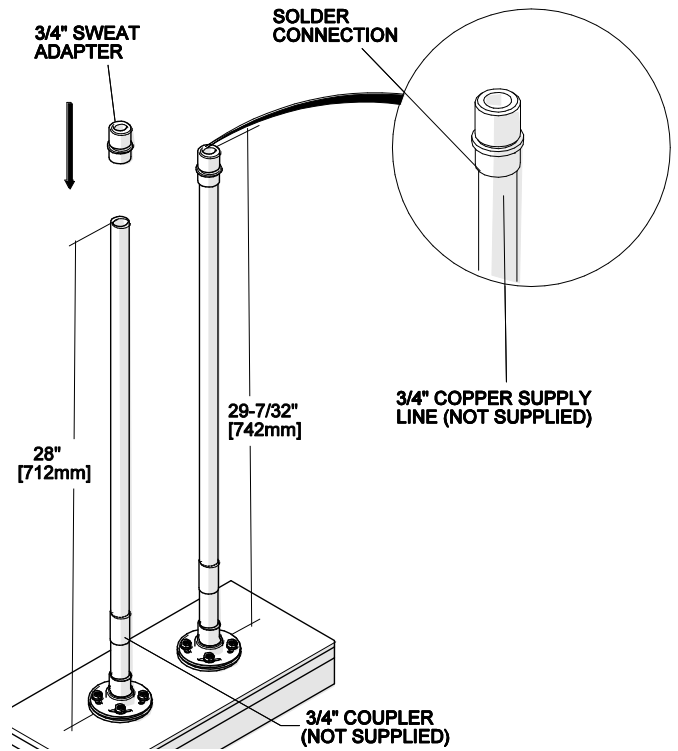

FIGURE - 03

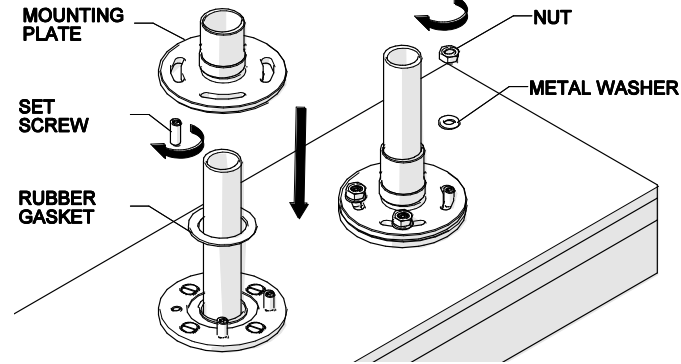

FIGURE - 02

- See Figure - 03 for Steps 10 & 11.
10. Using 3/4" couplers (not supplied), extend the supply lines and cut them to a height of 28" [712mm] above the finished floor. Make sure the cuts are flush and level.
 11. Dry fit the 3/4" SWEAT ADAPTERS onto the top of the supply. Make sure the ADAPTERS are flush and level with each other.

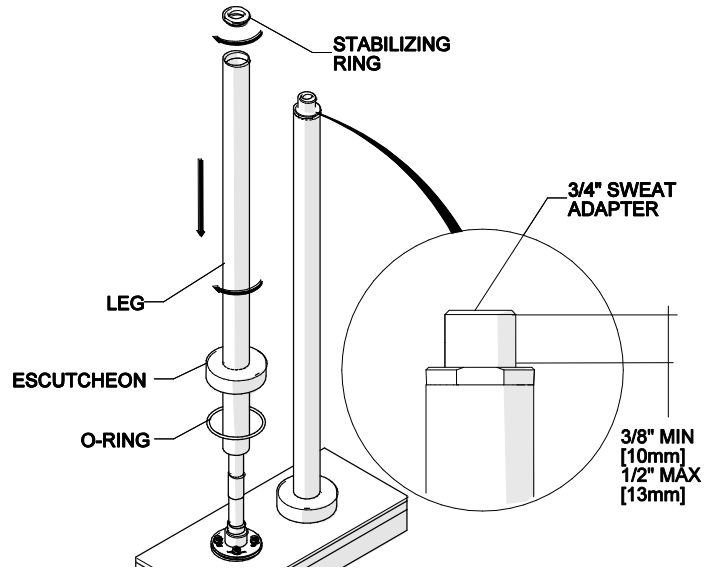

FIGURE - 04

- See Figure - 03 & 04 for Steps 12 - 15.
12. Dry fit the LEGS to the MOUNTING PLATES making sure the LEGS sit flush with the finished floor.
 13. Thread the STABILIZING RINGS onto the 3/4" SWEAT ADAPTERS until they are fully seated into the top of the LEGS.

These guidelines have been prepared for the professional contractor to aid in the installation of:
FLYTE EXPOSED FLOOR MOUNTED TUB FILLER (STYLE No. FLXT70)
 All dimensions are based on original specification and are subject to change and variation.
 Please consult your Design Associate for current specifications.

WATERWORKS
 STUDIO

14. Measure the amount of exposed threads above the STABILIZING RING and ensure that there are between 3/8" [10mm] and 1/2" [13mm] of exposed threads. If necessary, remove the LEGS and adjust the height of the SWEAT ADAPTERS by adjusting the height of the inlet tubes. Once verified, solder the SWEAT ADAPTER to the inlet tubes.
15. Secure the LEGS to the finished floor using the FINISHED SCREWS then ensure the STABILIZING RINGS are securely tightened.

TUB FILLER INSTALLATION:

- See Figure - 05 for Steps 16 - 19.

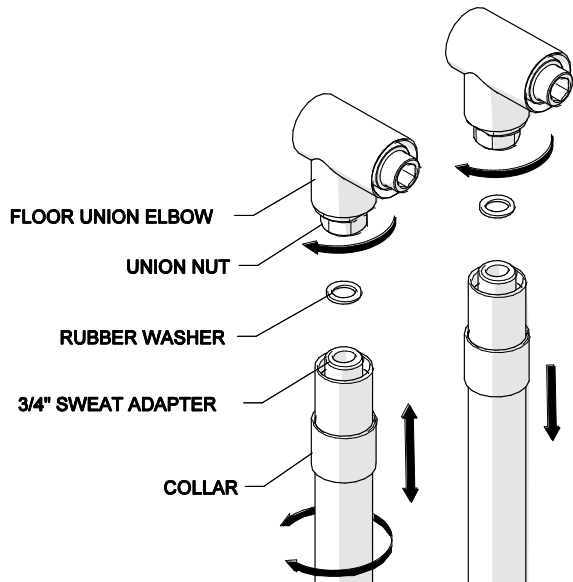

FIGURE - 05

16. Unthread and remove the COLLARS from the TUB FILLER ELBOW and insert them into the LEGS. Make sure the threaded ends of the COLLARS are pointed up.
 17. Position the FLOOR UNION ELBOW over the LEGS then thread the UNION NUTS onto the 3/4" SWEAT ADAPTERS. Make sure to use the RUBBER WASHERS provided.
 18. Securely tighten the UNION NUTS using a 30mm wrench.
 19. Slide the COLLARS up the LEG and thread them back onto FLOOR UNION ELBOW.
- See Figure - 06 for Steps 20 - 23.
20. Unthread the COLLAR from the VALVE BODY, and insert into FLOOR UNION ELBOW, with the threads facing out.
 21. Position the TUB FILLER BODY next to the COUPLER, and thread the UNION NUTS on to the COUPLER.

22. Securely tighten the UNION NUTS to the coupler using a 30mm wrench. Be sure RUBBER WASHER is included in each nut.
23. Thread the COLLAR back onto the VALVE BODY to conceal the UNION NUT.

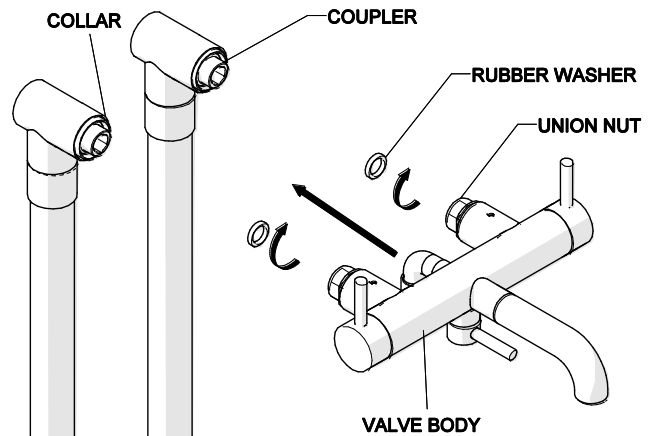

FIGURE - 06

HANDSHOWER INSTALLATION:

- See Figure - 07 for Steps 24 - 27.

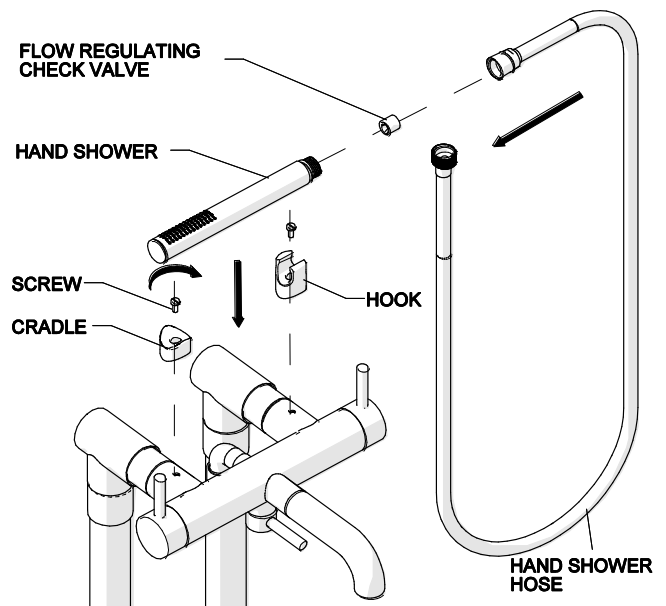

FIGURE - 07

24. Install the HANDSHOWER HOOK and CRADLE as shown in Figure - 07 onto the TUB FILLER BODY using the SCREWS provided. Ensure the HOOK is installed with the wider opening facing towards the inside.
25. Thread the conical end of the handshower hose to the end of the handshower, Ensure the FLOW REGULATING CHECK VALVE is installed in the inlet of the handshower.

These guidelines have been prepared for the professional contractor to aid in the installation of:
FLYTE EXPOSED FLOOR MOUNTED TUB FILLER (STYLE No. FLXT70)
All dimensions are based on original specification and are subject to change and variation.
Please consult your Design Associate for current specifications.

WATERWORKS
STUDIO

26. Thread the opposite end of handshower hose onto the HANDSHOWER ELBOW.

NOTE: A FLOW REGULATING CHECK VALVE is located in the inlet of the HANDSHOWER.

27. Place the HANDSHOWER on the hook.

INSPECT AND FINISH THE INSTALLATION:

28. Remove the AERATOR using the tool provided then turn on the hot and cold valves to flush out any debris in the supply lines before diverting to the HANDSHOWER.

NOTE: To divert water to the handshower, pull the KNOB on the TUB FILLER BODY.

29. Carefully inspect all connections for leaks and make sure all HANDLES are operating properly.

30. Re-install the aerator.

SERVICING:

- Service stops (not provided) should be turned off prior to servicing.
- See Figure - 08 for Steps 31 & 32.

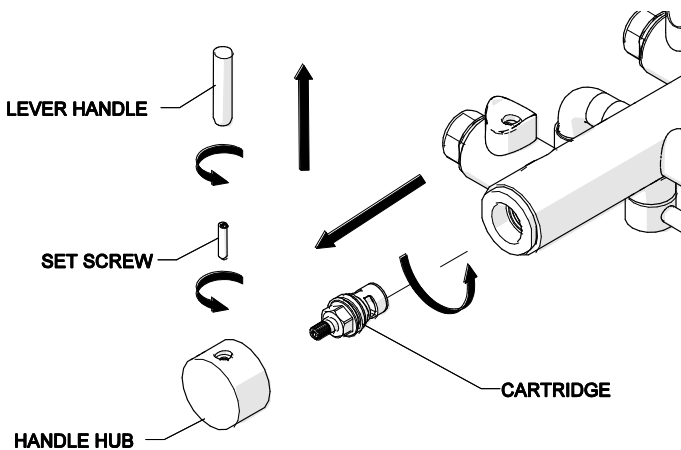

FIGURE - 08

31. To access the hot and cold CARTRIDGES, unthread the LEVER HANDLE, SET SCREW and remove HANDLE HUB.

32. Remove the CARTRIDGES using a 17mm wrench.

- See Figure - 09 for Steps 33 - 36.

33. Unthread DIVERTER HANDLE, and remove DIVERTER HUB.

34. remove DIVERTER CAM ASSEMBLY

35. Loosen SET SCREW on HANDSHOWER ELBOW, and then remove the elbow. Unthread DIVERTER CAPTURE.

36. Remove SHUTTLE

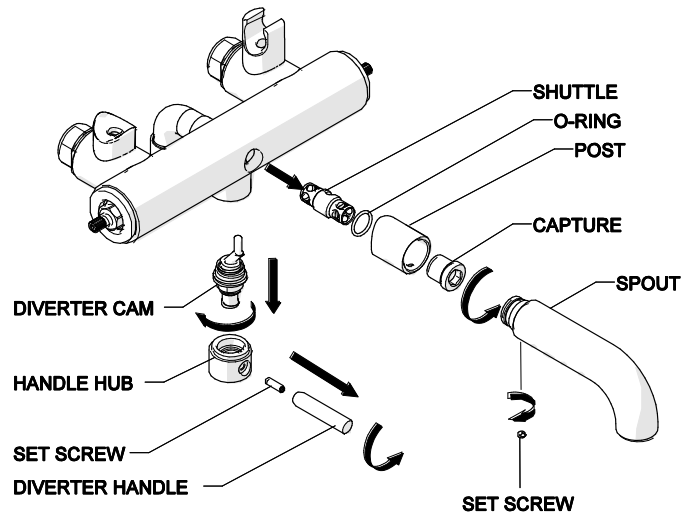

FIGURE - 09

- If further assistance is required, please contact Product Support at 1-800-927-2120 (8am-6pm EST).
- Refer to the separate Service Parts Documents for available replacement parts.