

Metal Wheel Handles  
**STYLE No. RWXS61<sup>†</sup>**

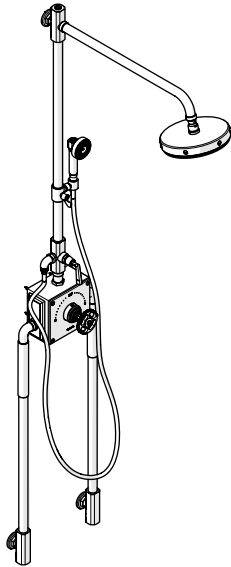

Metal Lever Handles  
**STYLE No. RWXS71<sup>†</sup>**

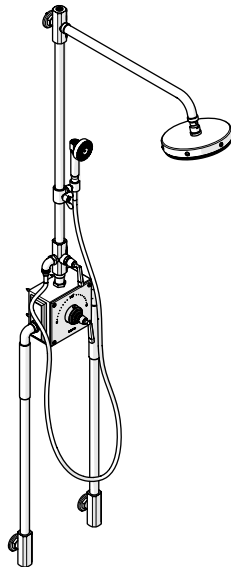

#### **SPECIFICATIONS:**

Adjustable versus Fixed Spray: Fixed Spray  
 Diameter of Head (Handshower): Ø2-11/16" [68mm]  
 Diameter of Head (Showerhead): Ø8-9/16" [217mm]  
 Handshower Hose Length: 60" [1.5m]  
 Height (Overall Adjustable): 79" [2007mm]  
 Fittings Hole Diameter: Ø1" [25mm]  
 Inlet Connection: 3/4" Copper Compression<sup>†</sup>  
 Inlet Spread: 11-3/4" **Maximum**  
 Inlet Spread: 11-1/2" **Minimum**  
 Integrated Diverter: Yes  
 Water Pressure: 85psi [6.0 bar] **Maximum**  
 Water Pressure: 20psi [1.5 bar] **Minimum**  
 Water Pressure Recommended: 45psi [3.0 bar]

<sup>†</sup> UK **STYLE No. RW61XS** and **RW71XS** supplied with 2 **BSP** Adapters each, assembly required.

#### **IMPORTANT:**

- **WARNING:** This product is large and heavy and it is strongly recommended that 2 or more persons install this unit.
- To ensure this product is installed properly, you must read and follow these guidelines.
- The owner/user of this product must keep this information for future reference.
- This product is supplied with the Waterworks Universal Thermostatic Valve (**STYLE No. GUTH37**) which features anti-scald protection.
- The risk of scalding exists until the installer has properly calibrated/adjusted the temperature setting during final trim installation. Refer to the Installation Guidelines of the thermostatic valve for additional information.
- Be sure your installation conforms to federal, state, and local codes.
- In the State of Massachusetts, all installations must comply with the rules and regulations set forth within 248 CMR.
- This product must be installed by a professional licensed contractor.
- Product should be on-site prior to rough-in. This allows the installer to visualize the installation and verify the center spread.
- Refer to the specification and assembly drawings attached. Product is **sold partially** assembled but shown fully disassembled for illustrative and service purposes only.
- Inspect this product to ensure you have all the parts required for proper installation.
- Use only a strap wrench or protected/smooth-jaw wrench on any finished surface.
- The use of certain plumber's putty may stain stone or tile surfaces.
- Install accessible **hot** and **cold** service stop valves to facilitate servicing.
- Run 3/4" [22mm] SUPPLY LINES for **maximum** flow.

#### **ROUGH-IN:**

- See Figure - 01 for Steps 1 - 3.
1. Determine the ideal location of the valve and inlet legs, based on user preference. The distance from the center of the valve to the inlet connections is 32-5/8" [828mm].  
**NOTE:** Make sure there is enough clearance after the floors and walls have been finished in the shower area.
  2. Run well supported 3/4" **hot** and **cold** copper SUPPLY LINES for **maximum** flow.
  3. Verify the supplies are secure and level. The inlets must have a spread of 11-1/2" [292mm] **MIN** to 11-3/4" [298mm] **MAX**. Make sure the **hot** supply is on the left and the **cold** supply is on the right. Cap off supplies and outlet and check for **leaks**.

These guidelines have been prepared for the professional contractor to aid in the installation of:  
 R.W. ATLAS EXPOSED THERMOSTATIC SYSTEM WITH HANDSHOWER, DIVERTER AND METAL WHEEL HANDLE  
 (**STYLE No. RWXS61, RW61XS**) AND METAL LEVER HANDLE (**STYLE No. RWXS71, RW71XS**).  
 All dimensions are based on original specification and are subject to change and variation.  
 PLEASE CONSULT YOUR DESIGN ASSOCIATE FOR CURRENT SPECIFICATIONS.

# WATERWORKS

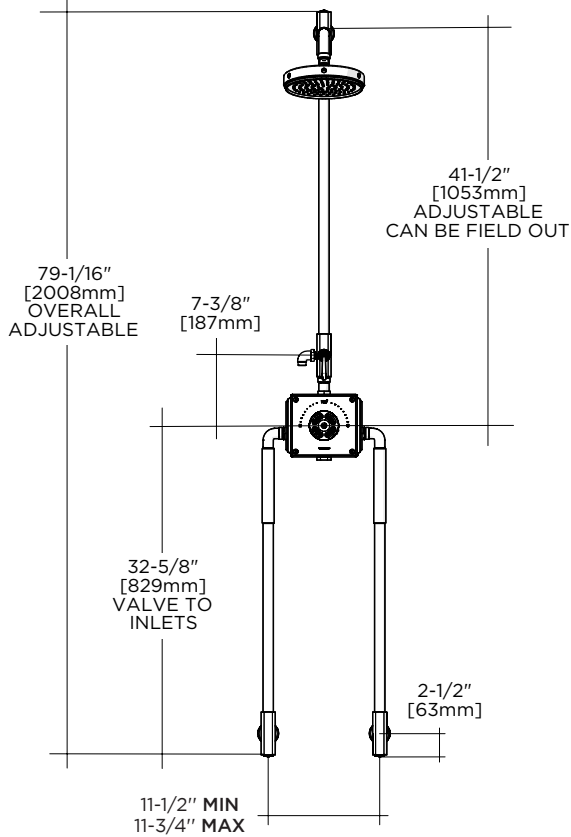

FIGURE - 01

- Cut the copper SUPPLY LINES so they extend 15/16" from the finished wall. See Figure - 02.

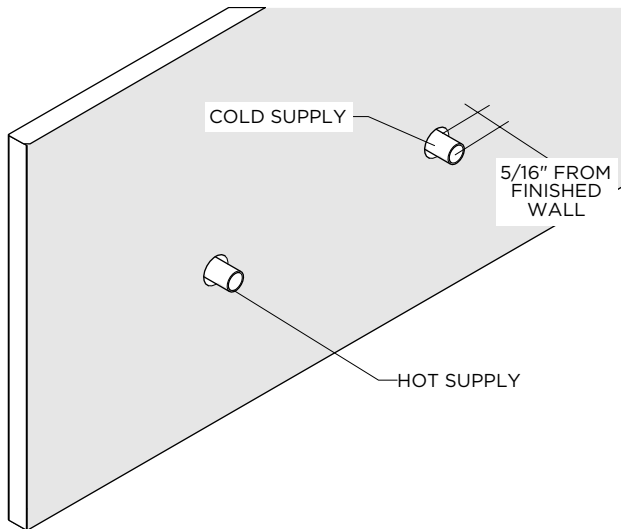

FIGURE - 02

**EXPOSED VALVE INSTALLATION:**

- Verify the inlet supply spread prior to installation, 11-1/2" [292mm] MIN to 11-3/4" [298mm] MAX.
- See Figure - 03 for Steps 5 - 15.

- **WARNING:** THIS INSTALLATION STEP WILL REQUIRE 2 PERSONS.

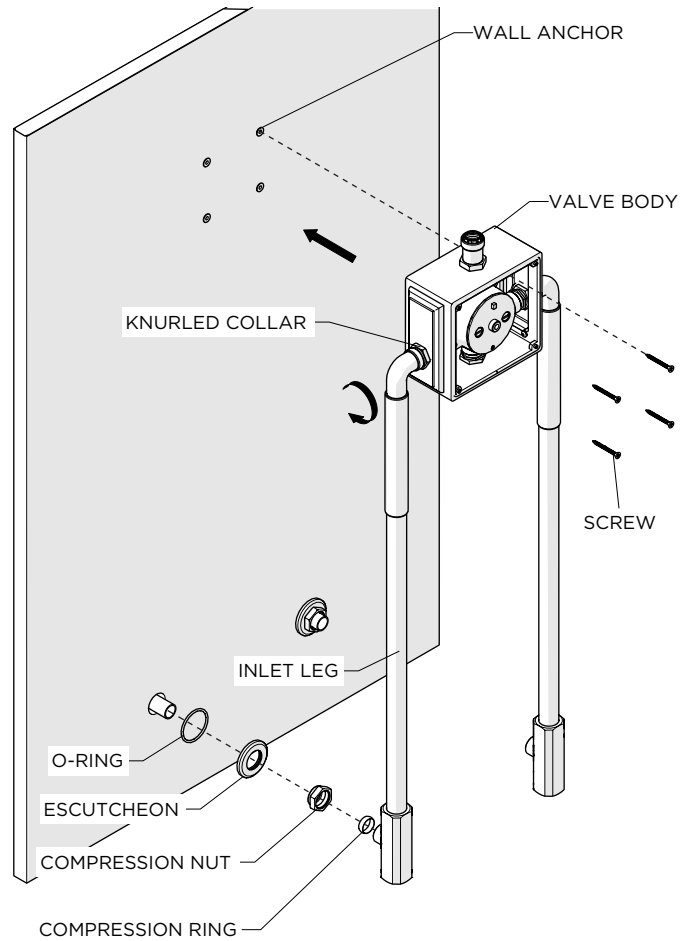

FIGURE - 03

- Unthread and remove the COMPRESSION NUTS and COMPRESSION RINGS, along with ESCUTCHEONS and O-RING from each inlet connection.
  - Slide an O-RING, ESCUTCHEON, COMPRESSION NUT and COMPRESSION RING over each inlet supply pipe, making sure the threading on the COMPRESSION NUTS are facing outwards.
  - Loosen the KNURLED COLLARS and thread the INLET LEGS into the VALVE BODY until they stop, then unthread enough so that they align with the supply pipes and outlet tube (**MAXIMUM 3 ROTATIONS**).
- + **NOTE:** The ELBOW seal is created by internal O-RINGS and **NOT** by fully tightening the ELBOW.
- Position the INLET LEGS onto the supply pipes along with the VALVE BODY until they are fully seated into the ELBOW and then hand tighten the COMPRESSION NUTS.

These guidelines have been prepared for the professional contractor to aid in the installation of: R.W. ATLAS EXPOSED THERMOSTATIC SYSTEM WITH HANDSHOWER, DIVERTER AND METAL WHEEL HANDLE (STYLE No. RWXS61, RW61XS) AND METAL LEVER HANDLE (STYLE No. RWXS71, RW71XS). All dimensions are based on original specification and are subject to change and variation. PLEASE CONSULT YOUR DESIGN ASSOCIATE FOR CURRENT SPECIFICATIONS.

9. Slide the ESCUTCHEONS back towards the wall.  
**NOTE:** If the gap is too large, and the ESCUTCHEONS slide off the COMPRESSION NUT, cut the supply pipes accordingly.
10. With the VALVE BODY level and up against the wall, mark the locations of the 4 mounting holes using the holes on the BACK PLATE of the VALVE BODY.
11. Loosen the COMPRESSION NUTS and remove the INLET LEGS and VALVE BODY.
12. Install the 4 ANCHORS provided using the marks made during Step 10.
13. Re-install the INLET LEGS along with the VALVE BODY onto the supply pipes making sure the ESCUTCHEONS are against the wall with the O-RINGS behind them then securely tighten the COMPRESSION NUTS using a 33mm wrench.
14. Tighten the KNURLED COLLARS so that they are tight against the side of the VALVE BODY.
15. Install the SCREWS, through the VALVE BODY and into the ANCHORS to fully secure the assembly.

**DIVERTER, RISER, AND SHOWER ARM INSTALLATION:**

- See Figure - 04 for Steps 16 - 20.

16. After the VALVE BODY and INLET LEGS are fully installed, connect the DIVERTER VALVE using the KNURLED NUT on the top of the VALVE BODY, making sure the RUBBER WASHER is between.
  17. With the KNURLED NUT securely tightened, make sure the DIVERTER VALVE is facing forwards then securely tighten the HEX NUT on top of the VALVE BODY.
  18. Attach the HANDSHOWER SLIDER to the SHOWER RISER and tighten the WING-NUT.
  19. Place SHOWER RISER with SHOWER ARM ASSEMBLY onto the top of the DIVERTER VALVE, making sure the RISER is fully seated into the DIVERTER VALVE and SHOWER ARM ASSEMBLY.
  20. Mark the center location of the ESCUTCHEON on the SHOWER ARM ASSEMBLY.  
**NOTE:** If the SHOWER ARM ASSEMBLY is too high, the SHOWER RISER can be field cut to the desired height.
- See Figure - 05 for Steps 21 - 24.

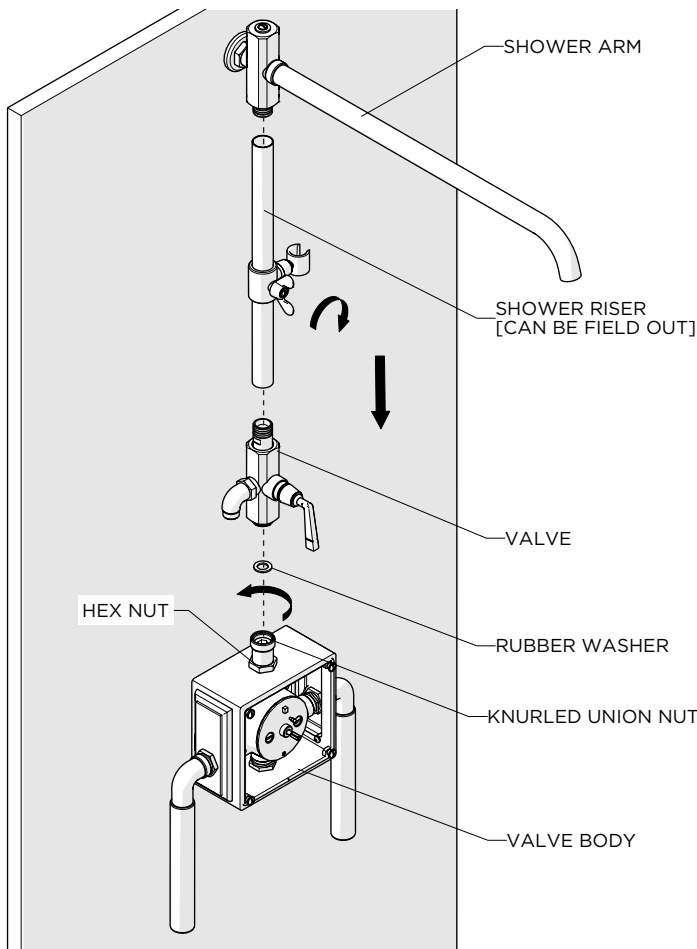

FIGURE - 04

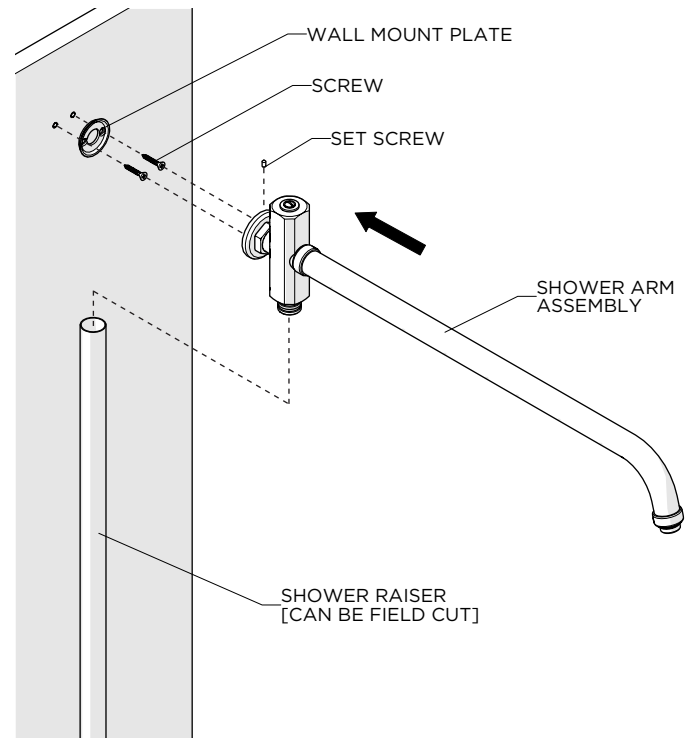

FIGURE - 05

21. Remove the SHOWER ARM ASSEMBLY from the SHOWER RISER then loosen the SET SCREW on the ESCUTCHEON to remove the WALL MOUNT PLATE.
  22. Install the WALL MOUNT PLATE at the center mark made in Step 20, using the SCREWS and ANCHORS.
  23. Carefully install SHOWER ARM ASSEMBLY back onto SHOWER RISER, while aligning the ESCUTCHEON over the WALL MOUNT PLATE. Adjust the SHOWER RISER if needed.
- **WARNING:** To prevent leaks, make sure the SHOWER RISER is fully seated into the DIVERTER VALVE and SHOWER ARM ASSEMBLY. Adjust as needed.

24. Once the SHOWER ARM ASSEMBLY is fully seated on the SHOWER RISER and mounted on the WALL MOUNT PLATE, securely tighten the SET SCREW.

**HANDSHOWER INSTALLATION (RWXS40 & 50 ONLY):**

➤ See Figure - 06 for Steps 25 - 26.

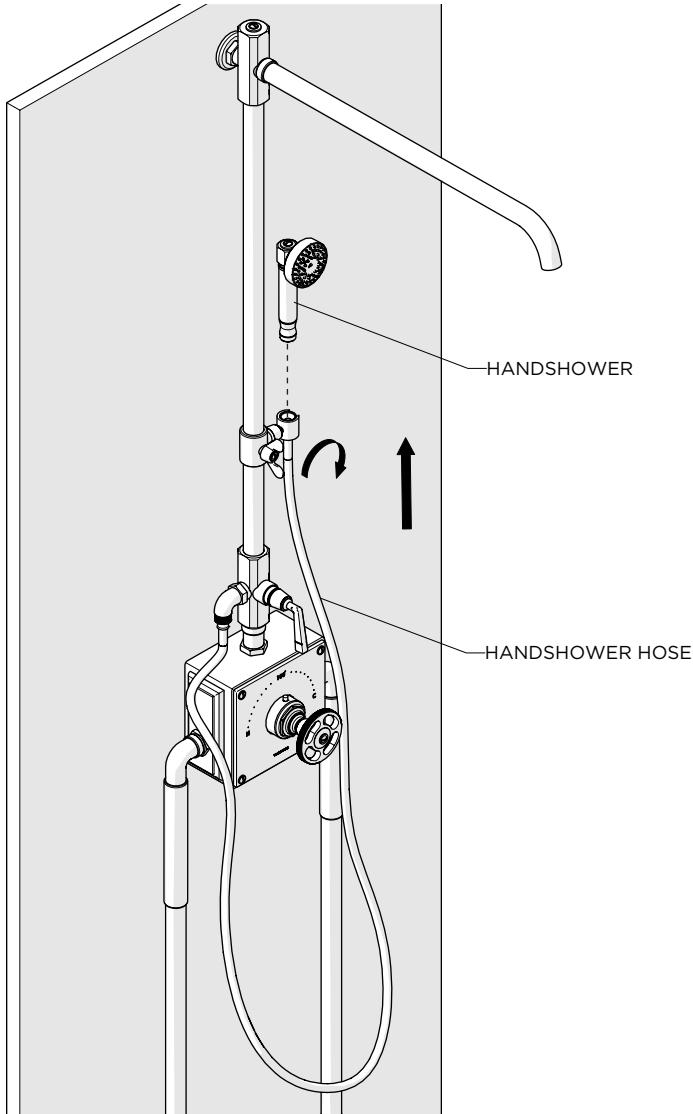

**FIGURE - 06**

25. Connect the knurled end of the HANDSHOWER HOSE to the DIVERTER VALVE then connect the conical end of the HOSE to the HANDSHOWER.

26. Place HANDSHOWER into the HOOK on the SLIDER.

**NOTE:** The HANDSHOWER SLIDER is adjusted by loosening the WING-NUT on the SLIDER and then re-tightening it at the desired height.

➤ See Figure - 07 for Steps 27 - 31.

➤ The SUPPLY LINES must be flushed out to prevent clogging of the FILTER SCREENS. Failure to flush the lines will permanently damage the CARTRIDGE and void the warranty.

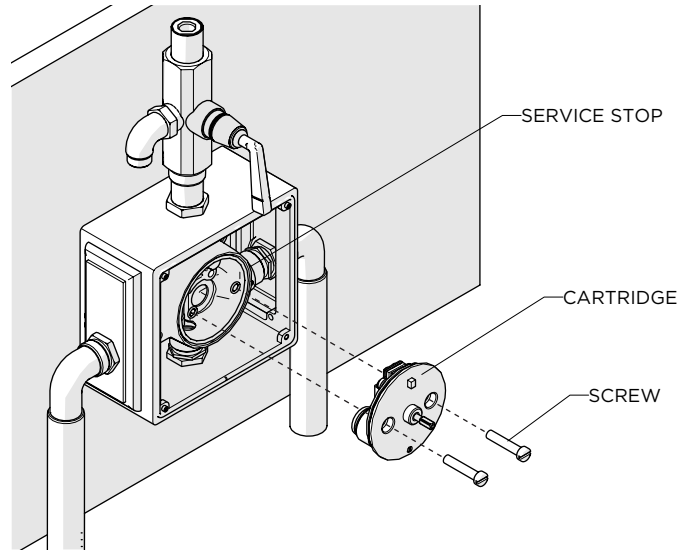

**FIGURE - 07**

27. This product comes pre-installed with a FLUSH PLATE and is ready for flushing the lines.

28. Remove the shower head and handshower.

29. Turn on the water supply to flush out the lines and inspect all connections for leaks.

30. After all the lines are flushed, turn off the water supply and remove the flush plate.

31. Install the CARTRIDGE using the 2 COVER SCREWS and turn the SERVICE STOPS off.

**TRIM PLATE INSTALLATION:**

➤ See Figure - 08 for Steps 32 - 34.

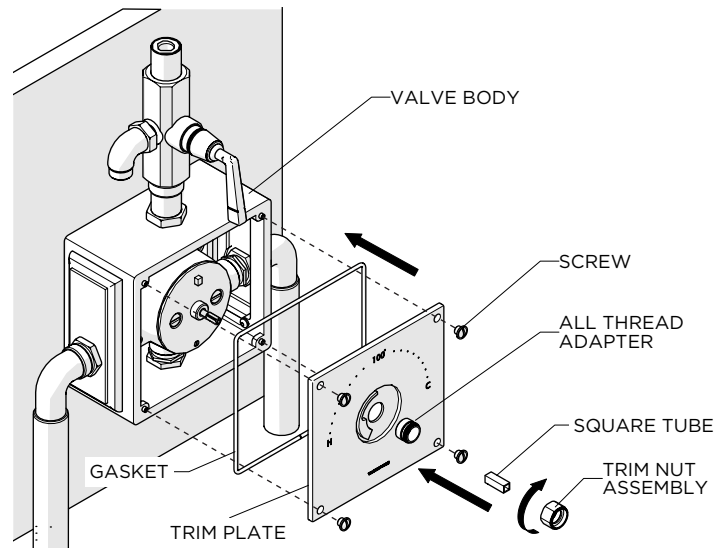

**FIGURE - 08**

32. Attach TRIM PLATE to the VALVE BODY using the 4 SCREWS, making sure the GASKET is behind the PLATE.

**CAUTION:** use a large slotted screwdriver to avoid damaging the SCREWS.

These guidelines have been prepared for the professional contractor to aid in the installation of: R.W. ATLAS EXPOSED THERMOSTATIC SYSTEM WITH HANDSHOWER, DIVERTER AND METAL WHEEL HANDLE (STYLE No. RWXS61, RW61XS) AND METAL LEVER HANDLE (STYLE No. RWXS71, RW71XS). All dimensions are based on original specification and are subject to change and variation. PLEASE CONSULT YOUR DESIGN ASSOCIATE FOR CURRENT SPECIFICATIONS.

33. Thread the ALL THREAD ADAPTER onto the CARTRIDGE until it stops.
34. Thread the TRIM NUT onto the ALL THREAD ADAPTER until it stops then insert the SQUARE TUBE into the TRIM NUT and over the CARTRIDGE STEM.

**NOTE:** Do **NOT** over-tighten the TRIM NUT.

#### TEMPERATURE CALIBRATION:

- The risk of scalding exists until the installer has properly calibrated the temperature setting.
- See Figure - 09 for steps 35 - 39.

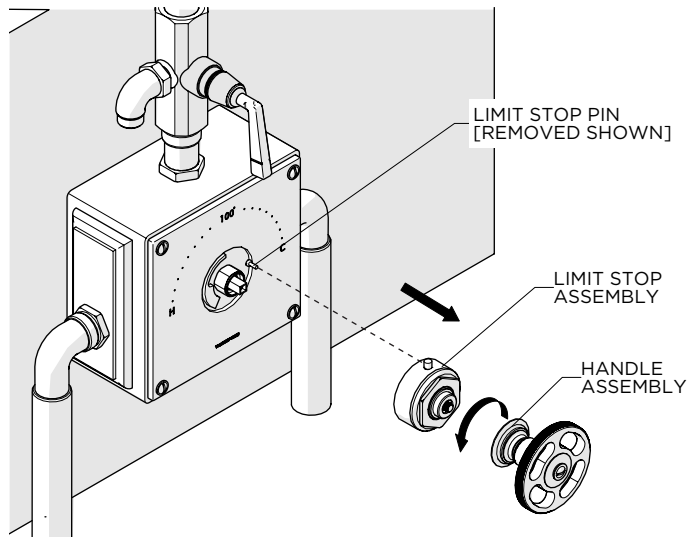

FIGURE - 09

35. Turn on the water supply and the DIVERTER VALVE to run water through the VALVE and insert a bladed screw driver into the SQUARE TUBE.
36. Slowly rotate the SQUARE TUBE clockwise to attain full **cold**, then rotate it counter-clockwise to attain full **hot**. Verify a full range of temperature exists.
 

**NOTE:** It is approximately 2 complete rotations from full **cold** to full **hot**.
37. With water running, rotate the SQUARE TUBE to adjust the temperature to the **maximum** desired bathing temperature, verified with a thermometer. Turn the water off and make sure not to change this temperature setting.
38. Unthread the HANDLE ASSEMBLY from the LIMIT STOP ASSEMBLY and loosen the (x4) SET SCREWS on the LIMIT STOP.
39. Insert the LIMIT STOP ASSEMBLY onto the TRIM NUT making sure the LIMIT STOP PIN (shown removed) makes contact with the limit stop on the TRIM PLATE then tighten the 4 SET SCREWS.
40. Turn the LIMIT STOP clockwise then turn the water on and confirm the LIMIT STOP is functioning properly by turning it counter-clockwise at which point it should stop.
41. Verify the temperature to be the **maximum** temperature set in Step 37. If it is **not** the correct temperature, repeat the calibration procedures in Steps 35 - 39.

42. To get a hotter temperature, press and hold the LIMIT STOP BUTTON, then rotate the LIMIT STOP until it stops. It is **NOT** recommended to exceed a safety limit stop of 110 degrees.
43. Re-attach the HANDLE ASSEMBLY to the LIMIT STOP.
44. Attach the SHOWER HEAD to the SHOWER ARM ASSEMBLY using Teflon tape (not provided) and the RUBBER WASHER to complete this installation. See Figure - 10.

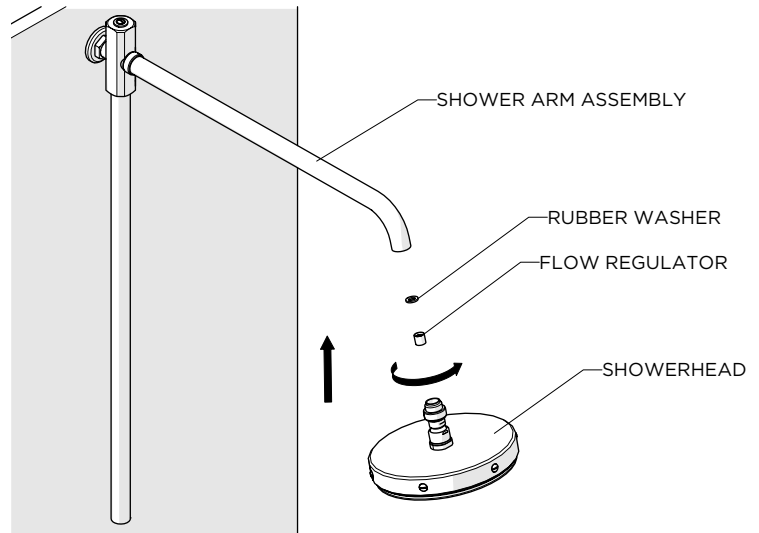

FIGURE - 10

- If further assistance is required, please contact Product Support at 1-800-927-2120 (8am-6pm EST).
- Refer to the separate Service Parts Documents for available replacement parts.

† **BSP Adapter** can be ordered separately:

(x2) **STYLE No.** UNUK10

**ITEM No.** 45-66512-23519