

STYLE No. RWXT40
Metal Wheel Handles

STYLE No. RWXT50
Metal Lever Handles

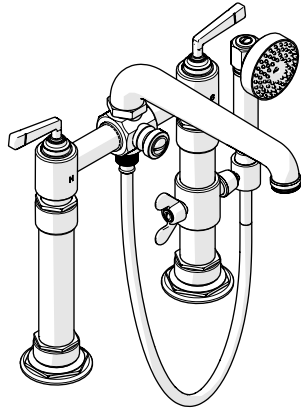
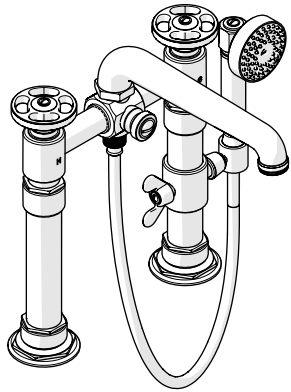

SPECIFICATIONS:

Adjustable versus Fixed Spray: Fixed Spray
Deck Thickness: 2-13/16" [71mm] **Maximum**
Diameter of Head: Ø2-11/16" [68mm]
Handle Spread: 8" [203mm] **(NOT ADJUSTABLE)**
Handshower Hose Length: 60" [1.5m]
Fittings Hole Diameter: Ø1-1/4" [32mm]
Inlet Connection: 3/4" Male NPT
Inlet Spread: 8" [203mm] **(NOT ADJUSTABLE)**
Integrated Diverter: Yes
Spout Outlet Height: 11-1/4" [286mm]
Spout Reach: 9" [229mm]
Spout Swivel: No
Water Pressure: 85psi [6.0 bar] **Maximum**
Water Pressure: 20psi [1.5 bar] **Minimum**
Water Pressure Recommended: 45psi [3.0 bar]

† Only the HANDSHOWER has a restricted flow rate.

IMPORTANT:

- To ensure this product is installed properly, you must read and follow these guidelines.
- The owner/user of this product must keep this information for future reference.
- Product should be on-site prior to rough-in. This allows the installer to visualize the installation and verify the center spread.
- This product must be installed by a professional licensed contractor. Be sure your installation conforms to federal, state, and local codes. Anti-scald protection is the responsibility of the installer and according to applicable codes. In the State of Massachusetts, all installations must comply with the rules and regulations set forth within 248 CMR.
- Refer to the specification and assembly drawings attached. Product is sold partially assembled but shown fully disassembled for illustrative and service purposes only.

- Check tub deck and tub measurements to assure the spout projects far enough into the tub.
- Inspect this product to ensure you have all the parts required for proper installation.
- Use only a strap wrench or protected/smooth-jaw wrench on any finished surface.
- The use of certain plumber's putty may stain stone or tile surfaces.
- Install accessible **hot** and **cold** service stop valves to facilitate servicing.
- Run 3/4" [22mm] SUPPLY LINES for **maximum** flow.

ROUGH-IN:

1. Run well supported 3/4" [22mm] **hot** and **cold** SUPPLY LINES for **maximum** water flow. The inlet supply spread is 8" [203mm] on-center and is **not adjustable**.
2. Drill Ø1-1/4" [32mm] holes in the mounting surface with the proper spread for each supply to pass through.

LEG INSTALLATION:

- See Figure - 01 for Steps 3 - 7.

FIGURE - 01

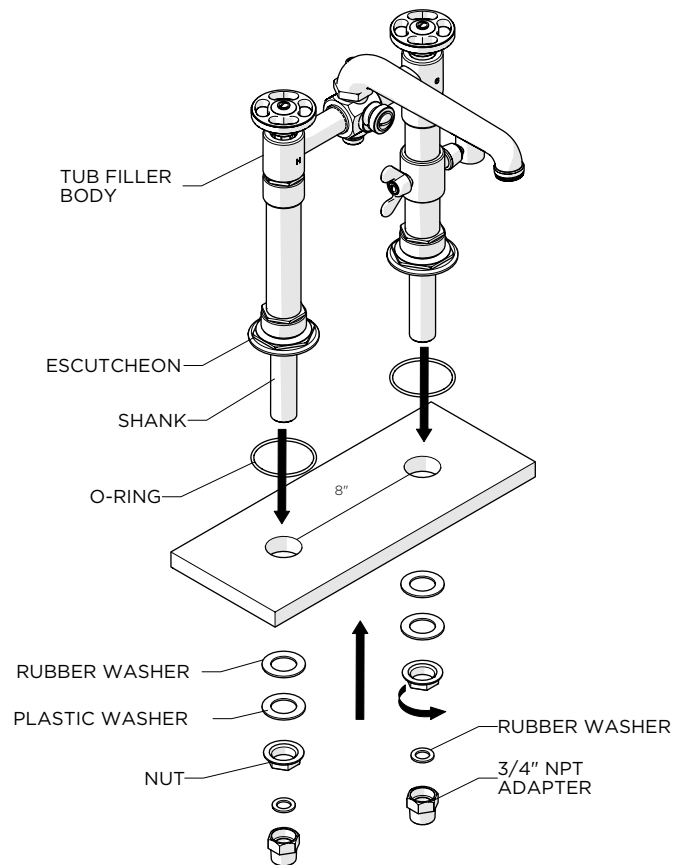

These guidelines have been prepared for the professional contractor to aid in the installation of: R.W. ATLAS EXPOSED DECK MOUNTED TUB FILLER WITH HANDSHOWER AND METAL WHEEL HANDLES (STYLE No. RWXT40) AND METAL LEVER HANDLES (STYLE No. RWXT50). All dimensions are based on original specification and are subject to change and variation. Please consult your Design Associate for current specifications.

3. Make sure the SPOUT is aligned properly and does not rotate. Ensure the HEX COLLAR at the base of the SPOUT is securely tightened.
4. Remove the 3/4" NPT ADAPTERS and MOUNTING HARDWARE from the SHANKS.
5. Insert the SHANKS through the holes on the mounting surface making sure the O-RINGS are beneath the ESCUTCHEONS.
6. Re-install the MOUNTING HARDWARE to the SHANKS.
7. Apply pipe thread compound to each SHANK then thread the 3/4" NPT ADAPTERS onto the SHANKS using the RUBBER WASHERS provided.
8. Apply pipe thread compound onto the male end of the 3/4" NPT ADAPTERS then thread them into 3/4" female NPT x sweat adapters (**not supplied**).
9. Adjust the supply line lengths as needed and complete final connections.
10. Tighten the MOUNTING HARDWARE using a 30mm wrench to secure the TUB FILLER to the mounting surface.

HANDSHOWER INSTALLATION:

- See Figure - 02 for Steps 11 - 12.

FIGURE - 02

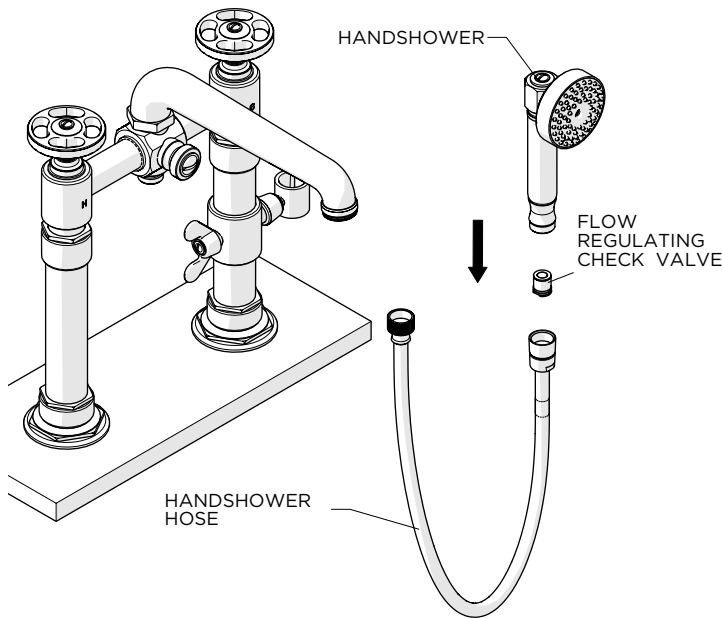

11. Connect the conical end of the HANDSHOWER HOSE to the HANDSHOWER then connect the knurled end to the TUB FILLER BODY.
NOTE: A FLOW REGULATING CHECK VALVE is located in the inlet of the HANDSHOWER.
12. Place the HANDSHOWER on the hook on the SLIDER.

INSPECT AND FINISH THE INSTALLATION:

13. Remove the AERATOR using the tool provided then turn on the **hot** and **cold** valves to flush out any debris in the SUPPLY LINES before diverting to the HANDSHOWER.
NOTE: To divert water to the handshower, pull the KNOB on the TUB FILLER BODY.
14. Carefully inspect all connections for **leaks** and make sure all HANDLES are operating properly before enclosing the unit.
15. Re-install the aerator.

SERVICING:

- Service stops (**not provided**) should be turned off prior to servicing.
- See Figure - 03 for Steps 16 - 20.

FIGURE - 03

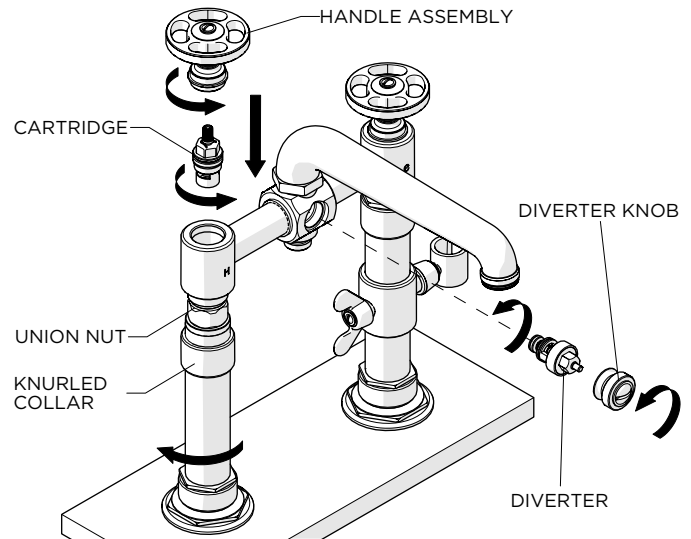

16. To access the **hot** and **cold** CARTRIDGES, unthread the HANDLE ASSEMBLY.
17. Remove the CARTRIDGES using a 17mm wrench.
18. To service the DIVERTER, pull the KNOB to expose the DIVERTER and remove using a 14mm wrench.
19. To remove the TUB FILLER BODY, unthread the BOTTOM CAPS to expose the UNION NUTS.
20. Unthread the NUTS using a 30mm wrench.
➤ If further assistance is required, please contact Product Support at 1-800-927-2120 (8am-6pm EST).
➤ Refer to the separate Service Parts Documents for available replacement parts.

These guidelines have been prepared for the professional contractor to aid in the installation of: R.W. ATLAS EXPOSED DECK MOUNTED TUB FILLER WITH HANDSHOWER AND METAL WHEEL HANDLES (STYLE No. RWXT40) AND METAL LEVER HANDLES (STYLE No. RWXT50). All dimensions are based on original specification and are subject to change and variation. Please consult your Design Associate for current specifications.