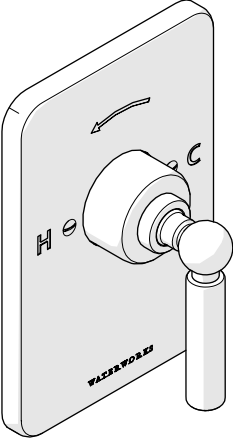
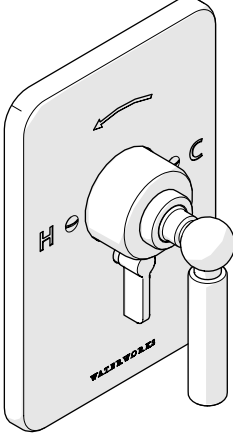
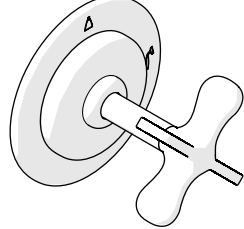
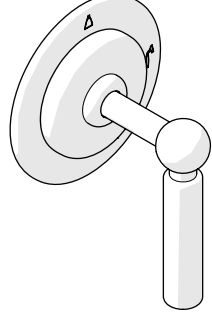
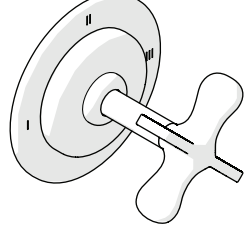
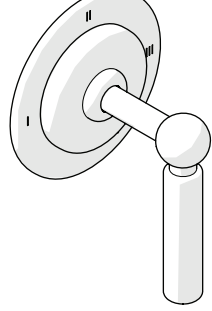

INSTALLATION GUIDELINES

LUDLOW PRESSURE BALANCE SHOWER SYSTEM

| | STYLE | DESCRIPTION |
|---|--------|--|
|  | LDPB11 | Ludlow Pressure Balance Control Valve Trim with Lever Handle |
|  | LDPB31 | Ludlow Pressure Balance with Diverter Trim with Lever Handle |

| | STYLE | DESCRIPTION |
|---|--------|--|
|  | LD2P01 | Ludlow Two Way Diverter Valve Trim for Pressure Balance with Graphics and Cross Handle |
|  | LD2P10 | Ludlow Two Way Diverter Valve Trim for Pressure Balance with Graphics and Lever Handle |
|  | LD3P01 | Ludlow Three Way Diverter Valve Trim for Pressure Balance with Roman Numerals and Cross Handle |
|  | LD3P10 | Ludlow Three Way Diverter Valve Trim for Pressure Balance with Roman Numerals and Lever Handle |

INSTALLATION GUIDELINES

LUDLOW PRESSURE BALANCE SHOWER SYSTEM

IMPORTANT:

- **ALL VALVES AND TRIMS SOLD SEPARATELY.**
- To ensure these products are installed properly, you must read and follow these guidelines.
- The owner/user of these products must keep this information for future reference.
- These products must be installed by a professional licensed contractor and must be on-site prior to rough-in. This allows the installer to visualize the installation.
- Be sure your installation conforms to all federal, state, and local codes. In the State of Massachusetts, all installations must comply with the rules and regulations set forth within 248 CMR.
- **WARNING:** PRESSURE BALANCE VALVES are equipped with an adjustable LIMIT STOP SCREW. The LIMIT STOP DEVICE is used to limit the temperature control HANDLE from being turned to undesired hot water discharge temperatures. Failure to adjust the LIMIT STOP SCREW properly increases the chances for serious injury.
- These products are sold partially assembled but shown fully disassembled for illustrative and service purposes only. Inspect these products to ensure you have all the parts required for proper installation.
- Use only a strap wrench or protected/smooth-jaw wrench on any finished surface.
- The use of certain plumber's putty may stain stone or tile surfaces.
- If further assistance is required, please contact Product Support at 1-800-927-2120 Monday through Friday, 8 am - 6 pm EST.
- Refer to the separate Service Parts Documents for available replacement parts.

CARE AND MAINTENANCE:

- If these products will remain unused for an extended period of time (over 3 months), then the water to the PRESSURE BALANCE VALVE should be shut off (via service stops or system control valve) and the VALVE should be opened to allow the remaining water in the VALVE to evaporate. This is to keep the PISTON in the CARTRIDGE from sticking, due to stagnant or hard water, once the VALVE is in use again. If the PISTON does stick, soak the CARTRIDGE in household vinegar.
- **WINTERIZE:** If this product will remain unused during the WINTER months then the water to the VALVE should be shut off (via service stops or system control valve) and the CARTRIDGE should be removed and replaced with the FLUSH PLATE.
- Refer to the Installation Guidelines provided with the PRESSURE BALANCE VALVE for:
 - Complete maintenance instructions, parts breakdown and related information.
 - Instructions on how to properly remove and re-install the CARTRIDGE.

REQUIRED PLUMBING DETAILS:

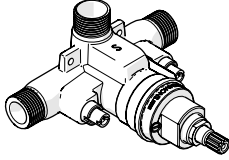
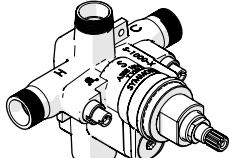
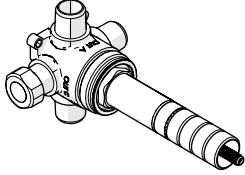
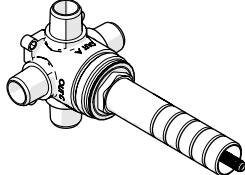
| | | VALVE | TRIM | NUMBER OF OUTLETS |
|------------------------|--|--------|----------------|-------------------|
| PRESSURE BALANCE VALVE |  | GUPB01 | LDPB11 | 2 |
| |  | GUPB02 | LDPB31 | 2 |
| DIVERTER VALVE |  | GUDV2P | LD2P01, LD2P10 | 2 |
| |  | GUDV3P | LD3P01, LD3P10 | 3 |

VALVE FUNCTION:

- PRESSURE BALANCE VALVES control on/off and mix hot and cold water.
 - The bottom outlet of the **GUPB01** is intended for use with a **diverting** tub spout only.
 - The bottom outlet of the **GUPB02** is intended for use with a **non-diverting** tub spout only and the use of any fitting with a restricted flow such as a handshower, will cause the integrated diverter to malfunction.
- DIVERTER VALVES can direct mixed water at a fixed volume to multiple devices. Water **cannot** flow out of the devices simultaneously (i.e. out of the showerhead AND handshower together).

INSTALLATION GUIDELINES

LUDLOW PRESSURE BALANCE SHOWER SYSTEM

ROUGH-IN AND VALVE PREPARATION:

- Refer to the Installation Guidelines provided with each VALVE for complete rough-in installation details and related information.
- **CAUTION:** The rough-in depth is measured from the centerline of the inlets to the surface of the finished wall. If the VALVES are roughed-in too shallow, the associated TRIMS cannot be installed correctly.
- The DIVERTER VALVE can ONLY be connected to the top outlet port of the PRESSURE BALANCE VALVE.
- Do **NOT** use:
 - The bottom (tub) outlet port of the PRESSURE BALANCE VALVE for any fittings with restricted flow, such as a handshower or body spray. The back pressure created would cause water to flow out through the top (shower) outlet port.
 - PEX piping from the VALVE to the tub spout. It will create too much back pressure and cause the VALVE to malfunction.
 - A shut-off device on either side of the PRESSURE BALANCE VALVE. The installation of any such device may create a cross-flow condition at the VALVE and affect water temperature.
- **IMPORTANT:** Make sure the supply lines are flushed prior to final TRIM installation using the FLUSH PLATE provided with the PRESSURE BALANCE VALVE.
- Remove and discard the TILE GUARDS only when the finished wall surface (TILE or SLAB) is completed and TRIMS are ready for installation.

| VALVE | DIMENSION | VALUE | |
|-------------------|-----------|---|------------------|
| GUDV2P, GUDV3P | A | 5-7/8" [149 mm] MAX 2-1/2" [64 mm] MIN | |
| | B | Ø2" [51 mm] | |
| GUPB01, GUPB02 | C | 2-7/8" [73 mm] MAX 2-1/8" [54 mm] MIN | |
| | D | GUPB01 | Ø3-1/2" [Ø89 mm] |
| | | GUPB02 | Ø3-3/4" [Ø95 mm] |

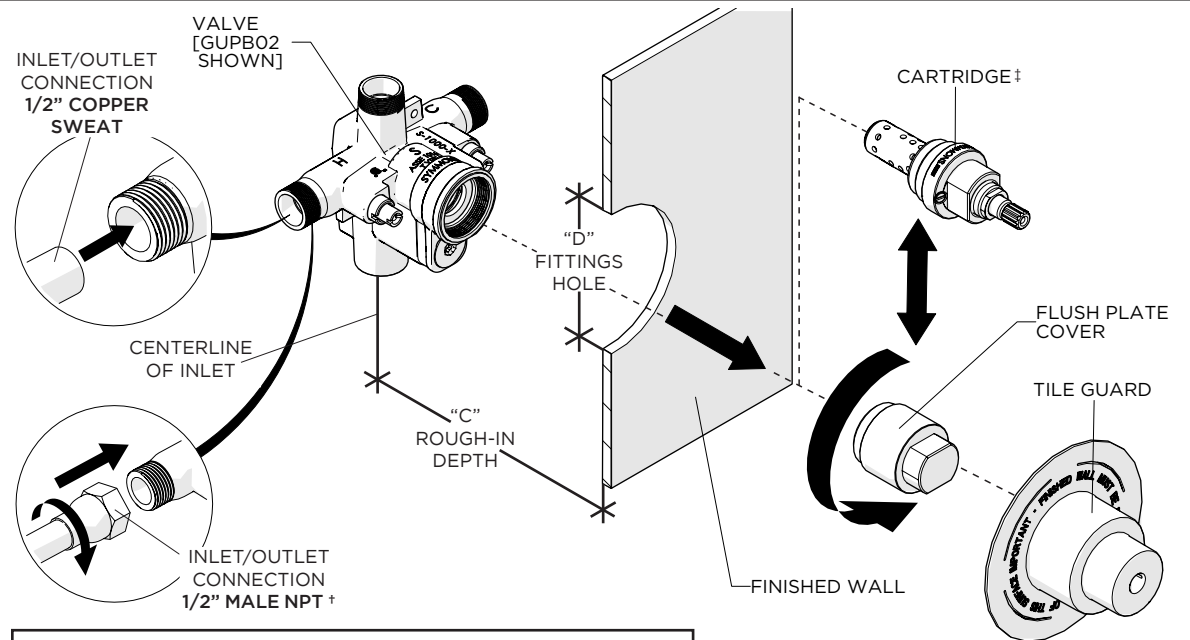
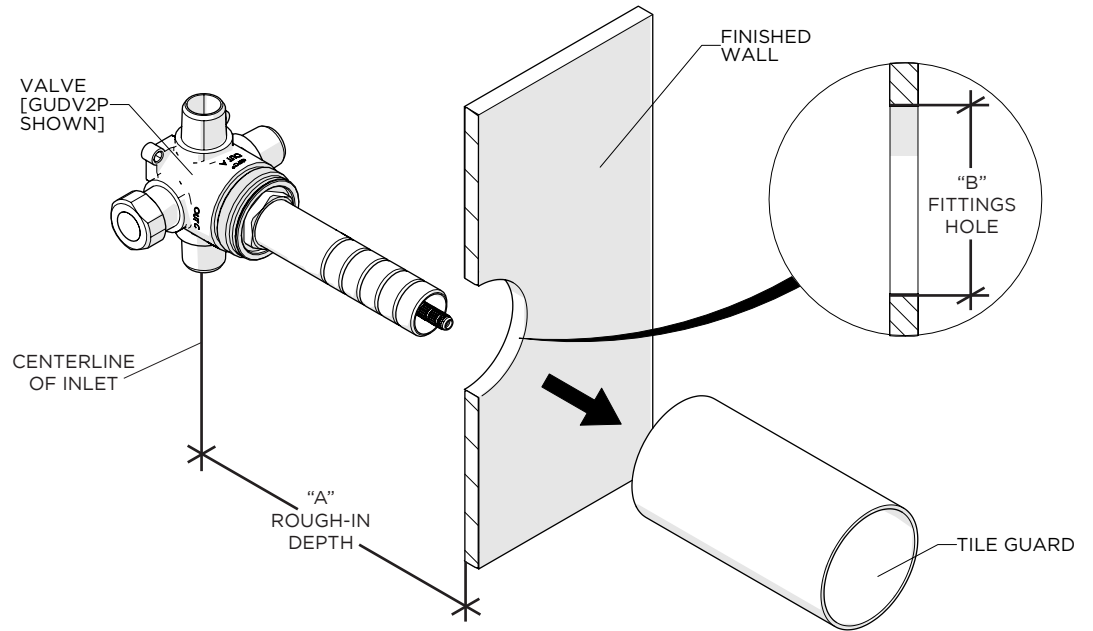

‡ **IMPORTANT:** The PRESSURE BALANCE CARTRIDGE, is packaged separately and provided with the VALVE. SET ASIDE UNTIL FINAL TRIM INSTALLATION!

INSTALLATION GUIDELINES

DIVERTER TRIM INSTALLATION

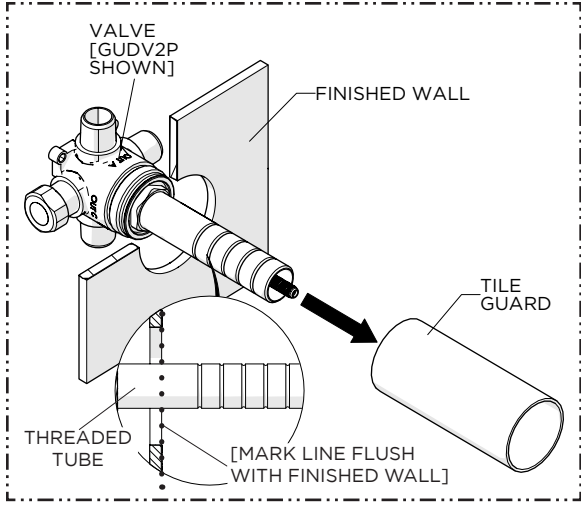

1. Remove the TILE GUARD when ready to install the TRIM then mark the THREADED TUBE where it protrudes past the finished wall.

NOTE: A straight edge (not supplied) can be used to mark the TUBE.

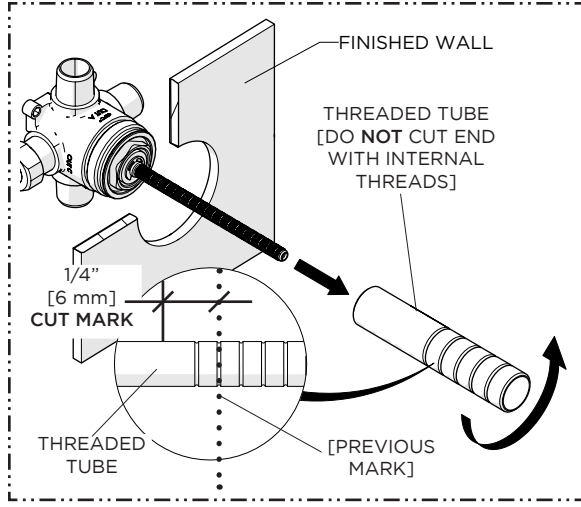

2. Remove the THREADED TUBE then cut it 1/4" [6 mm] behind the previous mark so the STEM will be 1/4" [6mm] below or recessed into the finished wall surface.

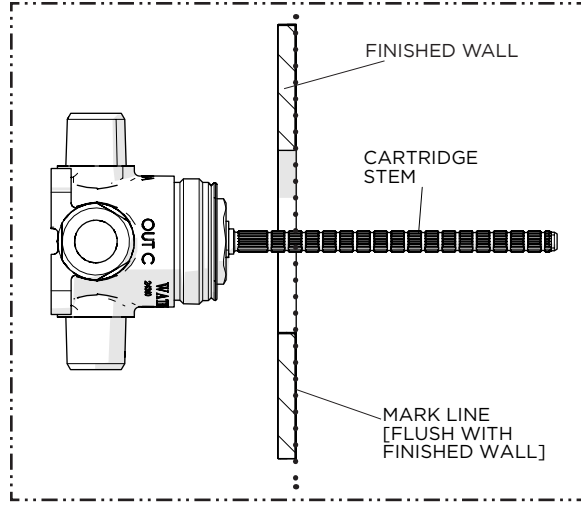

3. Mark the CARTRIDGE STEM where it protrudes past the finished wall.

NOTE: A straight edge (not supplied) can be used to mark the CARTRIDGE STEM.

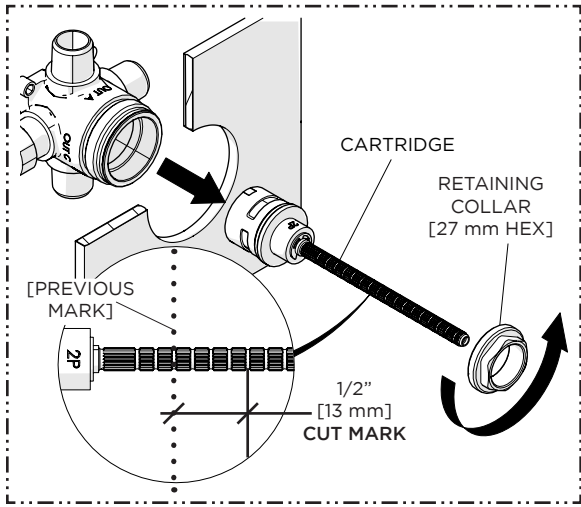

4. Unthread the RETAINING COLLAR and remove the CARTRIDGE then cut the CARTRIDGE STEM 1/2" [13 mm] in front of the previous mark so the STEM will protrude 1/2" [13 mm] from the finished wall surface.

CAUTION: Cutting the STEM longer than the specified dimension may result in the HANDLE being damaged when installed.

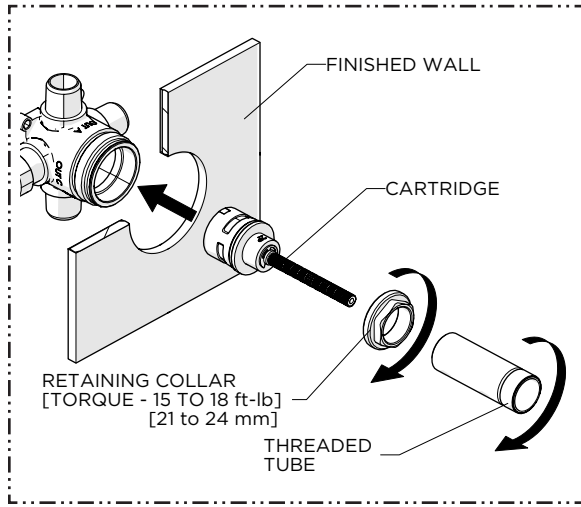

5. Re-insert the CARTRIDGE into the VALVE then thread and securely tighten the RETAINING COLLAR to the specified torque setting shown.

Thread the THREADED TUBE back into the RETAINING COLLAR until snug.

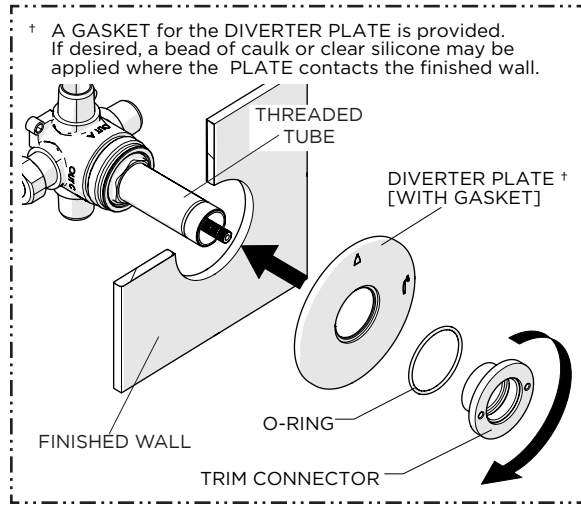

6. Firmly hold the DIVERTER PLATE against the finished wall then thread and securely tighten the TRIM CONNECTOR onto the THREADED TUBE making sure to use the O-RING provided.

INSTALLATION GUIDELINES

DIVERTER TRIM INSTALLATION

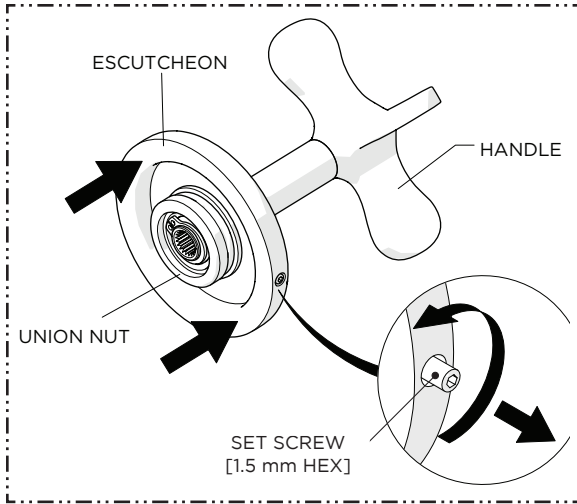

7. Loosen [do **NOT** remove] the SET SCREW at the base of the ESCUTCHEON then **CAREFULLY** slide the ESCUTCHEON up the HANDLE to expose the UNION NUT.

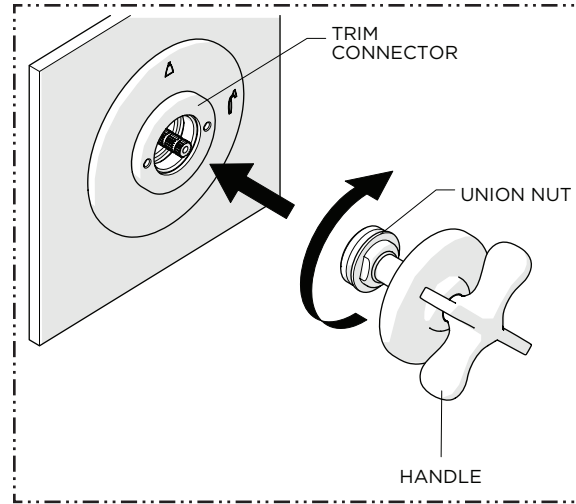

8. With the HANDLE in the desired orientation, thread the UNION NUT into the TRIM CONNECTOR until snug.

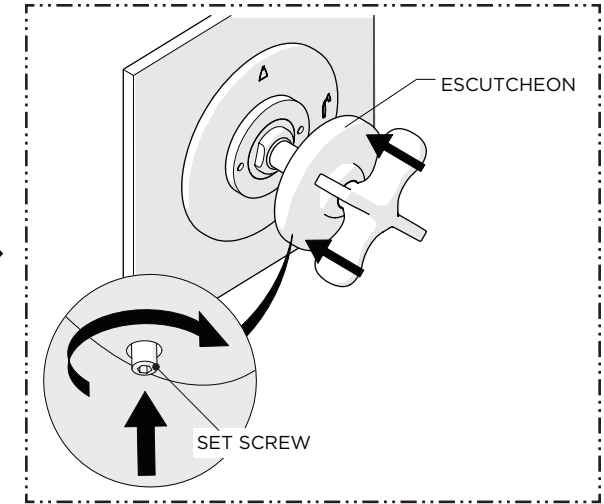

9. **CAREFULLY** slide the ESCUTCHEON down the HANDLE to conceal the TRIM CONNECTOR, then thread the SET SCREW to secure the position of the ESCUTCHEON.

PROCEED TO
PRESSURE BALANCE
TRIM INSTALLATION
ON PAGE 6

INSTALLATION GUIDELINES

PRESSURE BALANCE TRIM INSTALLATION

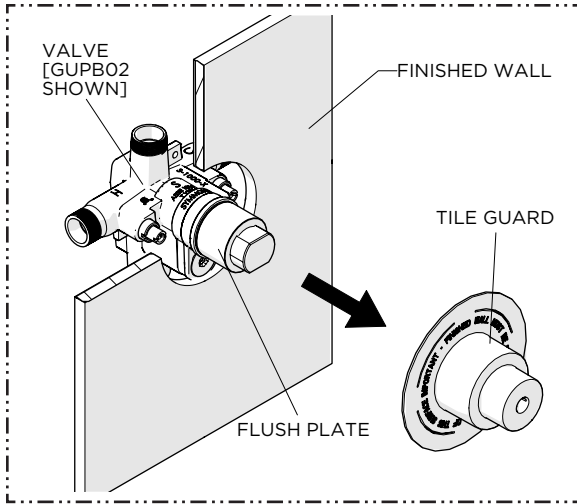

1. Remove the TILE GUARD from the VALVE when the TRIM is ready to be installed.

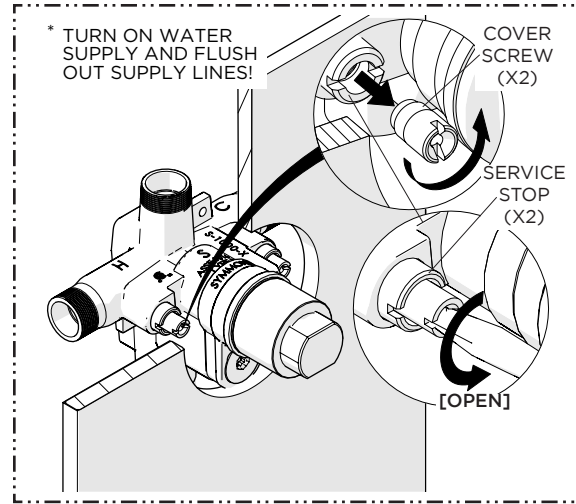

2. Turn on the water supplies then remove the COVER SCREWS (X2) and **OPEN** the SERVICE STOPS (hot & cold) to flush out the supply lines.

CAUTION: FAILURE TO FLUSH THE SUPPLY LINES WILL PERMANENTLY DAMAGE THE CARTRIDGE AND VOID THE WARRANTY! REPEAT THE FLUSHING PROCESS AS NEEDED BEFORE FINAL TRIM INSTALLATION.

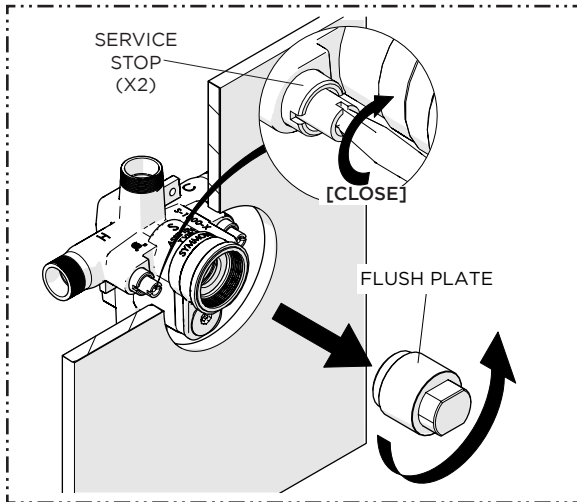

3. After the lines have been fully flushed, **CLOSE** the SERVICE STOPS (hot & cold) then unthread and remove the FLUSH PLATE.

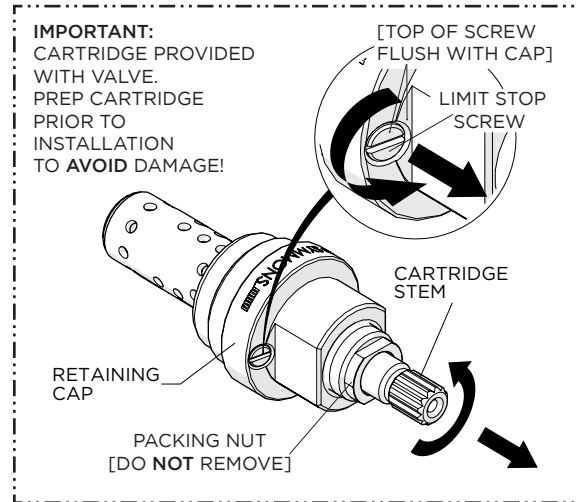

4. **IMPORTANT:** Leaving the PACKING NUT in place, unthread the LIMIT STOP SCREW until the O-RING is fully exposed then rotate the CARTRIDGE STEM counterclockwise to ensure the CARTRIDGE is drawn as close as possible to the RETAINING CAP.

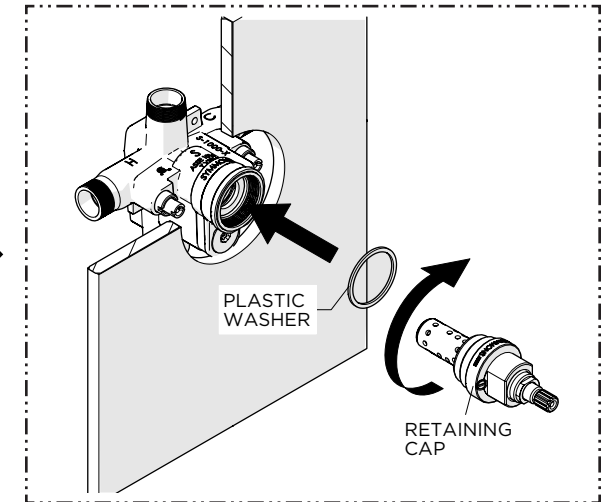

5. Using the PLASTIC WASHER provided, insert the CARTRIDGE into the VALVE then thread and securely tighten the RETAINING CAP.

NOTE: The CARTRIDGE controls on/off and temperature only, **not** volume.

INSTALLATION GUIDELINES

PRESSURE BALANCE TRIM INSTALLATION

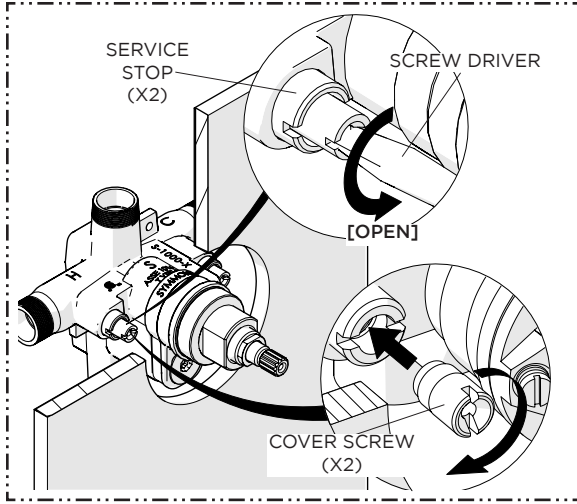

6. **OPEN** the SERVICE STOPS (hot & cold) then re-install the COVER SCREWS (X2).

NOTE: The VALVE will **not** operate unless both hot and cold supplies are turned on.

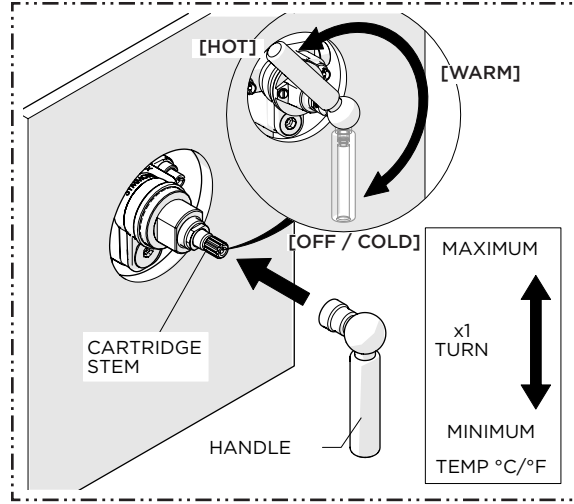

7. With the VALVE turned off, position the HANDLE on the CARTRIDGE STEM at the 6 o'clock position. Then, turn the HANDLE counterclockwise through the cold and warm settings, stopping at the hot position. Verify that a full range of temperatures exists.

NOTE: It's approximately 1 complete rotation.

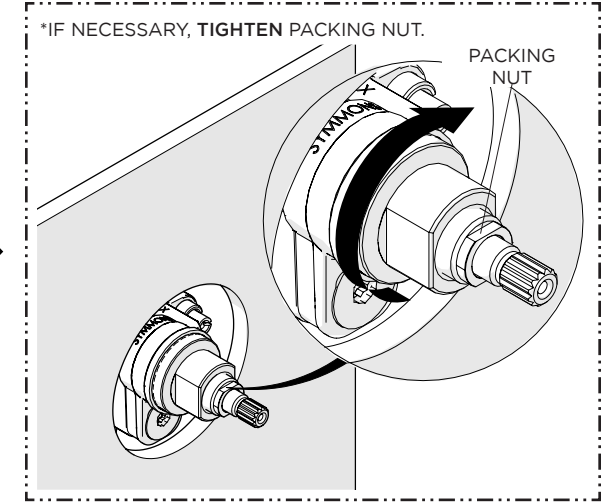

8. The PACKING NUT needs to be **securely** tightened to prevent a water leak from the CARTRIDGE STEM and create adequate rotational friction to maintain HANDLE position.

If additional friction is required, tighten the NUT further into the RETAINING CAP.

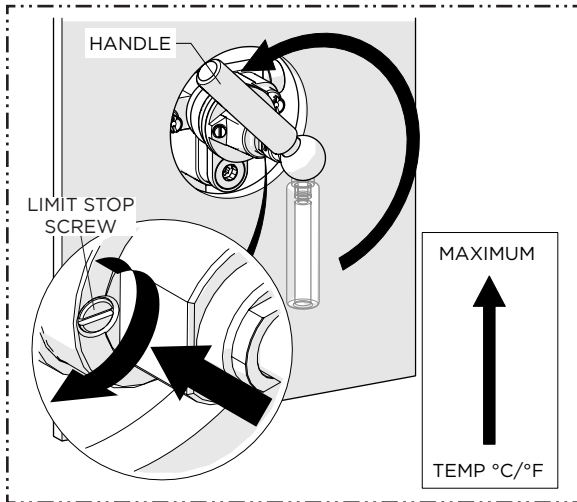

9. Open the VALVE to the **maximum** desired bathing temperature verified with a thermometer then turn the LIMIT STOP SCREW clockwise until it seats.

Turn the VALVE off then on and verify the temperature previously set.

WARNING: It is **NOT** recommended to exceed a safety limit stop of **37.8°C/100°F**.

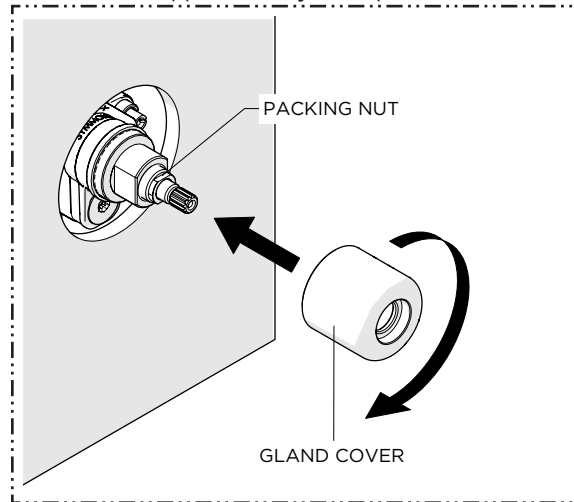

10. Thread and securely tighten the GLAND COVER onto the PACKING NUT.

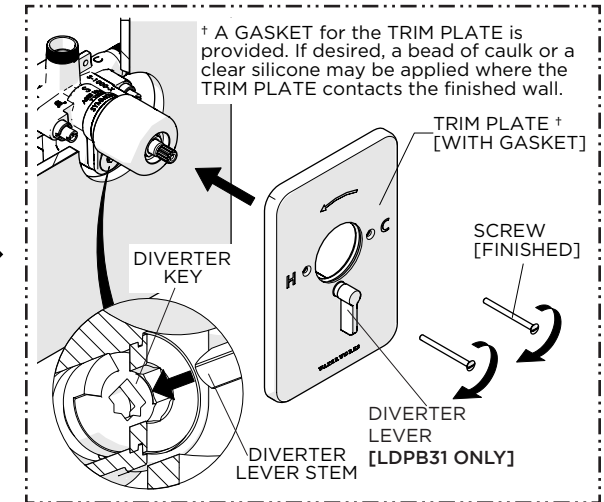

11. Slide the TRIM PLATE over the GLAND COVER then thread and securely tighten the SCREWS.

LDPB31 ONLY: Make sure the DIVERTER LEVER STEM is properly aligned with the DIVERTER KEY inside the VALVE (**GUPB02 ONLY**).

INSTALLATION GUIDELINES

PRESSURE BALANCE TRIM INSTALLATION

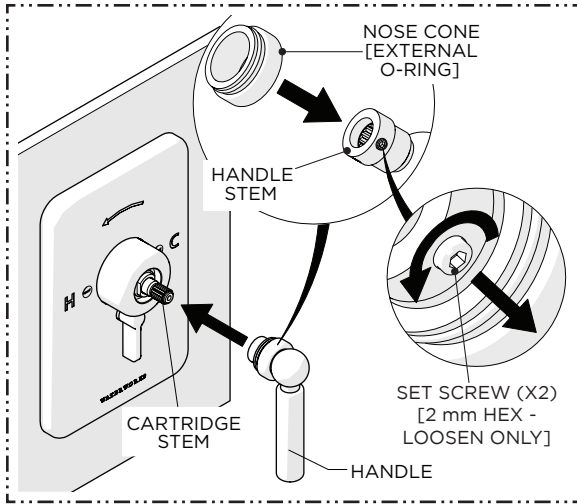

12. Slide the NOSE CONE over the HANDLE STEM then loosen the SET SCREWS (X2) and attach the HANDLE to the CARTRIDGE STEM.

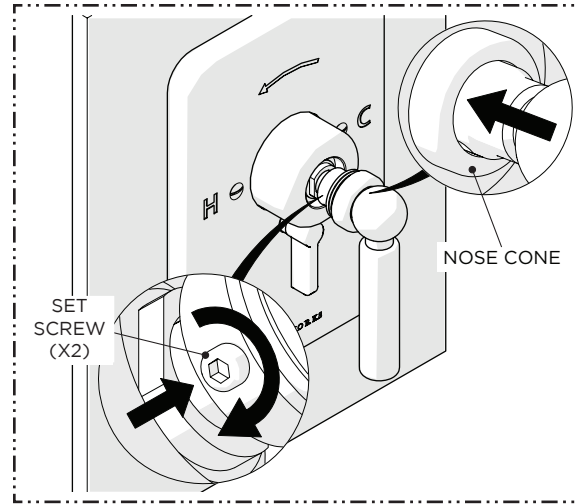

13. With the HANDLE fully seated, securely tighten the SET SCREWS (X2) then push the NOSE CONE into the GLAND COVER.

NOTE: The NOSE CONE will conceal the SET SCREWS and the external O-RING will hold it in place.

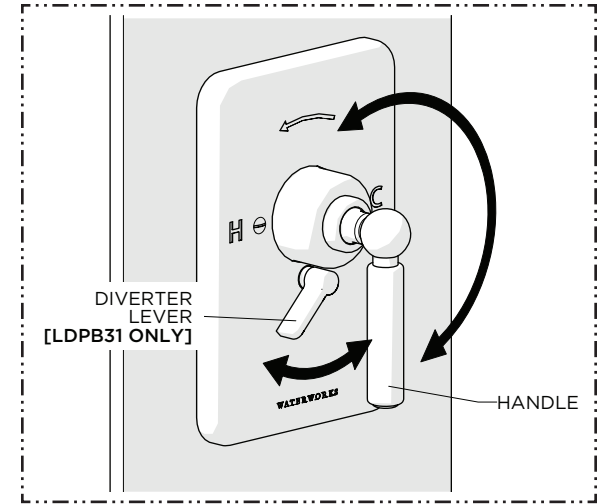

14. Operate the PRESSURE BALANCE TRIM and DIVERTER TRIM, if used, to ensure they are functioning properly.

TROUBLESHOOTING

1. VALVE will not flow water.

- **CAUSE:** Hot and cold water not turned on or SERVICE STOPS not opened.
- **SOLUTION:** Be sure both supplies are turned on and both SERVICE STOPS are open. The VALVE will not operate unless both hot and cold water inlets have pressure.

2. VALVE leaks when shut-off.

- **CAUSE:** Hot and cold water WASHERS are worn or foreign matter (solder, chips, etc.) are between WASHERS and SEAT surfaces.
- **Solution:** Replace hot and cold washers and inspect top surface on hot and cold seats for damage. Refer to the Installation Guidelines provided with the VALVE for more details.

3. VALVE makes loud noise.

- **CAUSE:** PISTON in CARTRIDGE is moving back and forth because of a large pressure differential between hot and cold water lines.
- **SOLUTION:** Alter the water system such that the pressure differential at all shower valves is no more than 5 psi (0.3 Bar).

4. Temperature out of VALVE reduces gradually during use.

- **CAUSE:** Supply system is running out of hot water.
- **SOLUTION:** Reduce **maximum** flow rate out of VALVE or showerhead. This will allow longer period of use before reduction of hot water supply.

5. Water volume from VALVE is inconsistent during operation, VALVE delivers an insufficient quantity of hot and cold water, or temperature fluctuates without moving temperature HANDLE.

- **CAUSE:** CONTROL PISTON housed in the CARTRIDGE is blocked from free movement by foreign matter.
- **SOLUTION:** With VALVE open half way, remove the temperature control HANDLE and tap the CARTRIDGE STEM with a plastic hammer. If problem is not solved refer to the Installation Guidelines provided with the VALVE to properly remove the CARTRIDGE then tap the handle end of the CARTRIDGE against a solid object to free the piston and rinse the CARTRIDGE. Soaking in house-hold vinegar will help free debris build up.

6. **GUPB02 ONLY:** When VALVE is set for shower operation, a trickle of water runs from the tub spout.

- **CAUSE:** This is a design function of the VALVE in accordance with national standards. Water is allowed to trickle from the tub spout when the diverter is set to the shower position.
- **SOLUTION:** This is a design function in accordance with national standards.

7. Outlet water temperature, in the full hot position, from the VALVE is lower than inlet water temperature or lower than another fitting such as a faucet in the same room, opened to full hot.

- **CAUSE:** This is a design function of the VALVE. The VALVE will always allow some cold water through in the full hot position. The difference from the inlet to outlet temperature is related to the pressure balance between the hot and cold supplies. The more the pressures are imbalanced the more the temperatures will vary.
- **SOLUTION:** If a hotter outlet water temperature is needed, the inlet water temperature must be adjusted. Refer to the Installation Guidelines provided with the VALVE for more details.