

AERO

AE88TF

Aero Low Profile Concealed Tub Filler With Handshower and Metal Cross Handles



SHOWN IN AERO LOW PROFILE CONCEALED TUB FILLER WITH HANDSHOWER AND METAL CROSS HANDLES| AETF88

TECHNICAL DETAILS

ADA Compliance: Yes
 Adjustable versus Fixed Spray: Fixed Spray
 Deck Thickness Maximum: 41 mm
 Deck Thickness Minimum: 0 mm
 Diameter of Head: 51 mm
 Escutcheon Primary Material: Brass
 Fittings Hole Diameter: 35 mm
 Flow Restriction Options: 2.0, 1.75, 1.5, 0.92
 Handle Spread Maximum: 305 mm
 Handle Spread Minimum: 254 mm
 Handle Turn Angle: Quarter Turn
 Handshower / Spray Hose Length: 2.0 m
 Depth / Width: 305 mm
 Height: 152 mm
 Inlet Connection Size: 3/4"
 Inlet Connection Type: Male G/BSPP
 Inlet Supply Spread Maximum: 305 mm
 Inlet Supply Spread Minimum: 254 mm
 Installation Type: Deck Mounted
 Integrated Diverter: N
 Length: 533 mm
 Number of Handles: Two
 Number of Holes: Four Hole
 Pivot: N
 Primary Material: Brass
 Restricted Maximum Flow Rate: 9.5 liters/min
 Spout Swivel: N
 Suggested Application: Bath
 Valve Material: ceramic
 Water Pressure Maximum: 5.5 bar
 Water Pressure Minimum: 1.5 bar
 Water Pressure Recommended: 3.0 bar

INSPIRATION

Inspired by the stepped detail of 19th century telescopes, Aero is a combination of historical reference with a contemporary temperament. The result is original and modern, bringing a look of updated elegance.

CODES & STANDARDS

Code # : ASME A112.18.1, CSA B125, IAPMO, State of MA

PRODUCT FEATURES

Metal cross handles

Lift knob located on top of spout to divert water between tub and handshower

Features signature stepped and gadrooned details on escutcheon

Stocked in Chrome and Nickel

Unrestricted flow for tub spout. Stocked in 2.5gpm (9.5L/min) flow rate for handshower. Alternate flow regulation of 1.75gpm (6.6/min) also available as special order

WATERWORKS

AERO

AE88TF

Aero Low Profile Concealed Tub Filler With Handshower and Metal Cross Handles

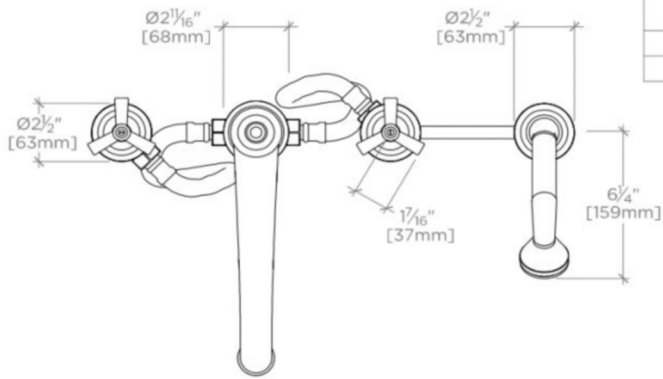

ADAPTER(S) PACKAGED SEPARATELY		
ADAPTER	DESCRIPTION	QTY
UNUK05	3/4" NPT Female x 3/4" Male BSP	2

TOP VIEW

SCALE: 1 1/2"=1'-0"

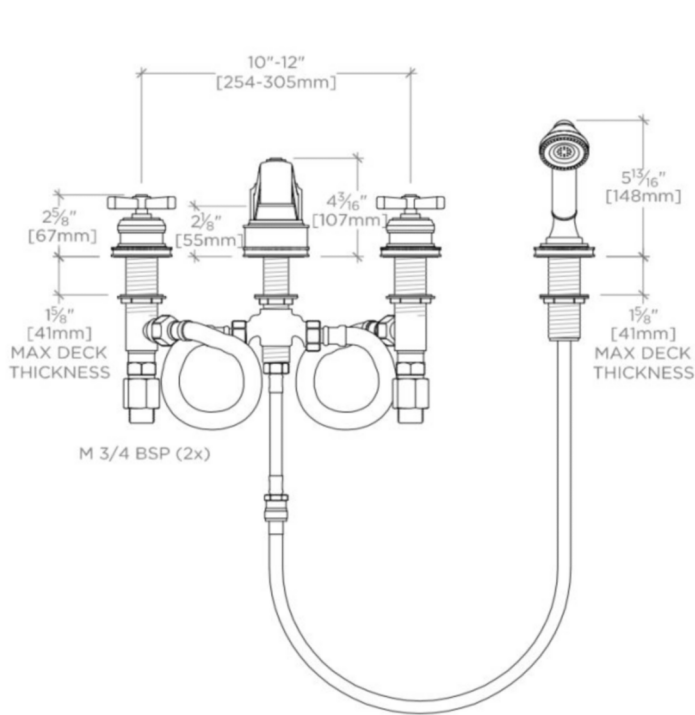

FRONT VIEW

SCALE: 1 1/2"=1'-0"

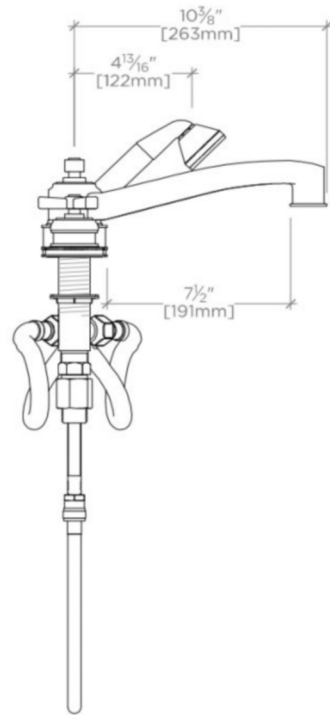

SIDE VIEW

SCALE: 1 1/2"=1'-0"