

GUSV37R/78R

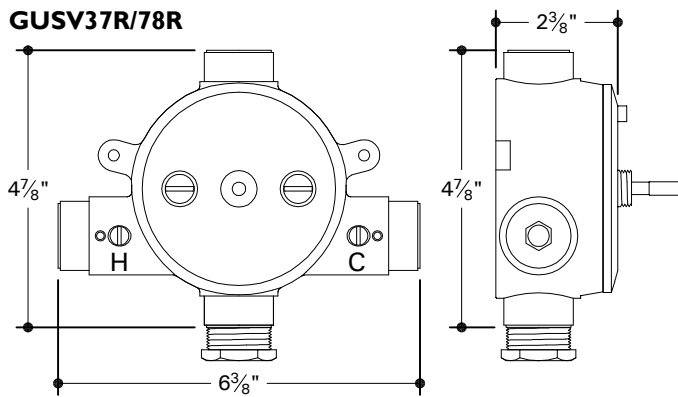

IMPORTANT

- **To ensure this product is installed properly, you must read and follow these guidelines.**
- **The owner/user of the valve must keep this information for future reference.**
- **This valve includes integrated service stops. Make sure the tile guard is in place.**
- **This valve features anti scald protection. The risk of scalding exists until the installer has properly calibrated/adjusted the temperature setting during final trim installation.**
- Valve body rough-in depth is measured from the centerline of the inlets to the surface of the finished wall and varies depending on the trim used. See step #2 below.
- This thermostatic valve only mixes hot and cold water and does not have volume control or shut off capability. A diverter or wall valves (provided separately) control on/off/volume and must be installed for each fitting that will have water flowing to it.
- This product must be installed by a professional contractor.
- Refer to the specification and assembly drawings attached. Valves are sold partially assembled but shown fully disassembled for illustrative and service purposes only.
- If soldering any connections, remove cartridge to prevent damage to seals and internal assembly.

- The trim should be on-site prior to rough in and allows the installer to visualize the installation.
- Inspect this product to assure you have all parts shown that are required for proper installation.
- Check incoming water pressure; ideal operating pressure is 40-60 psi. Maximum pressure is 80 psi. per most plumbing codes.
- Check local building and plumbing codes to ensure that your installation conforms to all applicable requirements.
- Supply fittings are designed in accordance with pressure and temperature ratings specified in ASME A112.18.1/B125 and ASSE 1016.

ROUGH IN:

1. Make sure the valve body (5) is positioned according to valve markings so the inlets are situated with hot piped on the left and cold piped on the right. Positioned correctly, notice the inlets are below an imaginary horizontal line drawn between the 2 cover screws (3).
2. **IMPORTANT:** Valve **rough-in depth** is measured from the centerline of the inlets to the surface of the finished wall and varies depending on the trim used :
 - GUSV78R:**
.25 (PTSV): 3 7/8"-4" Depth. Tile opening for the .25 (PTSV) trim must be between 6 5/8" and 7" diameter.
 - GUSV37R:**
Opus (OPSV): 2 7/8"-4 1/2" Depth.
All other trim: 2 1/2" minimum depth.
3. Run 3/4" copper supply lines to the proper height of the valve inlets and be sure to secure all piping and fittings.
4. For each fitting that will have water flowing to it, install a wall valve or diverter valve (both provided separately) at the same rough in depth and according to the flow direction arrow marked on the wall valve or diverter valve body.
5. The bottom port of the valve body is plugged (5a), but can be used to supply water to other fittings.
6. Install the tile guard (1).

These guidelines have been prepared for the professional contractor to aid in the installation of:
TM5 CONCEALED THERMOSTATIC SHOWER VALVE ROUGH (GUSV37R/78R)
 All dimensions are based on original specification and are subject to change and variation.
 Please consult your Design Associate for current specifications.

W A T E R W O R K S

FLUSH OUT THE SYSTEM:

The supply lines must be flushed out to prevent clogging of the filter screens. Failure to flush the lines will permanently damage the cartridge and void the warranty.

7. The valve body is shipped with the flush plate installed (4,4a) but without the cartridge installed and is ready for flushing the lines.
8. Turn on the water supply to flush out the lines then inspect all connections for leaks.
9. After the lines are flushed, turn off the water supply, unthread the 2 cover screws (3,3a), then remove the flush plate.
10. Install the cartridge/cover plate (2) using the 2 cover screws and turn off the service stops (6).
11. Install the tile guard (1).

If further assistance is required, please contact Product Support at 1-800-927-2120 (8am-7pm EST).

These guidelines have been prepared for the professional contractor to aid in the installation of:
TM5 CONCEALED THERMOSTATIC SHOWER VALVE ROUGH (GUSV37R/78R)
All dimensions are based on original specification and are subject to change and variation.
Please consult your Design Associate for current specifications.

W A T E R W O R K S

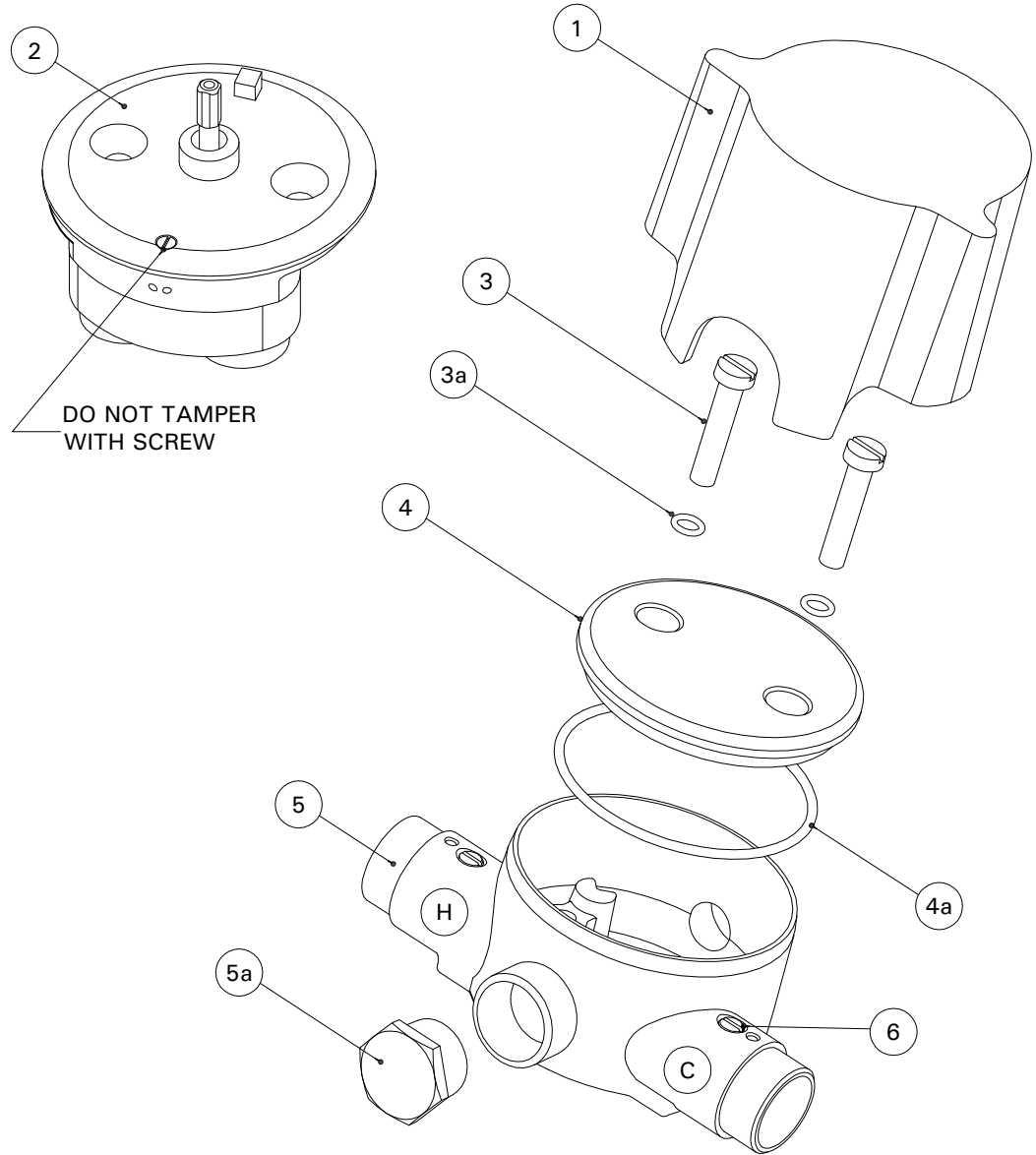

PARTS TABLE

ITEM NO.	DESCRIPTION	QTY.
1	TILE GUARD	1
2	CARTRIDGE W/INTEGRATED COVER PLATE	1
3	COVER PLATE SCREWS	2
3a	COVER PLATE SCREW O-RINGS	2
4	FLUSH PLATE	1
4a	FLUSH PLATE O-RING	1
5	VALVE BODY	1
5a	LOWER OUTLET PLUG	1
6	INTEGRATED SHUT OFF SCREW (HOT or COLD)	2

These guidelines have been prepared for the professional contractor to aid in the installation of:
TM5 CONCEALED THERMOSTATIC SHOWER VALVE ROUGH (GUSV37R/78R)
 All dimensions are based on original specification and are subject to change and variation.
 Please consult your Design Associate for current specifications.

W A T E R W O R K S

Care and Cleaning

The lustrous finish on your fitting or fixture should be treated with care. To clean the finish, wipe gently with a soft damp cloth and then with a soft dry towel. A mild soap solution can be used for daily cleaning. The use of non-recommended polishes, abrasive cleaners, solvents, ammonia-based products, or acid-based cleaners may damage the finish. Please know that improper handling or cleaning may damage the surface of the finish and consequently void the warranty.

Water contains lime and other minerals that are deposited after the water has evaporated. You can prevent deposits from forming by always wiping the fitting or fixture dry after use.

Please note the following points are specific to certain finishes or products only. Always read and follow the instructions when using any cleaning or polishing products.

BATHTUBS; CHINA, CERAMIC AND PORCELAIN

In addition to mild soap and water, a non-abrasive basin tub and tile cleaner is recommended for regular cleaning and disinfecting. Do not use abrasive cleaners or cleansers, as this will dull the surface finish. The use of any other cleaners or disinfectants may alter the surface finish.

CLOTHILDE TUB

Tin Coated Interior - Tin is a soft metal and should only be regularly cleaned with mild soap and water. The use of any other cleaners or disinfectants will alter the surface finish, removing the tin.

Copper Exterior - In addition to mild soap and water, a natural citrus-based product may be used for regular cleaning. The use of any other cleaners or disinfectants may alter the surface finish. Cape Cod® Polishing Cloths may be used for occasional polishing. If you desire additional protection, the use of Faucet Brite® will aid in cleaning and protecting the surface finish from mineral deposits present in your water supply. Faucet Brite® should be reapplied as necessary for continued protection.

WHIRLPOOL AND AIR TUB SYSTEMS

Jet Fresh® whirlpool cleaning solution is recommended for maintaining the waterways.

ANTIQUE COPPER, ANTIQUE BRASS, SHINY COPPER

Select Waterworks fittings and basins are offered in finishes that have been artificially weathered, creating a patina that will develop and change with time. In addition to mild soap and water, a natural citrus-based product may be used for regular cleaning. The use of any other cleaners or disinfectants may alter the surface finish. Please note that prolonged contact with certain items such as toothpaste, acidic fruits and vegetables, and wines will alter the surface finish. The use of polishing agents will remove the patina and restore the metal to its original shine. Once removed, the patina will naturally redevelop with time.

ARCHITECTURAL BRONZE

In addition to mild soap and water, a natural citrus-based product may be used for regular cleaning. The use of any other cleaners or disinfectants may alter the surface finish. Please note that prolonged contact with certain items such as toothpaste, acidic fruits and vegetables, and wines will alter the surface finish. The use of polishing agents will remove the finish.

NICKEL, MATTE NICKEL, CHROME, MATTE CHROME, MATTE GOLD, LUMIN, GOLD, CONCORDIA, SOVEREIGN

In addition to mild soap and water, a natural citrus-based product may be used for regular cleaning. The use of any other cleaners or disinfectants may alter the surface finish. Cape Cod® Polishing Cloths may be used for occasional polishing. If you desire additional protection, the use of Faucet Brite® will aid in cleaning and protecting the surface finish from mineral deposits present in your water supply. Faucet Brite® should be reapplied as necessary for continued protection.

SILVER, MATTE SILVER

Fittings offered in a silver finish will tarnish with age. This finish may be restored to its original luster by using Faucet Brite® or a non-abrasive silver polish. Faucet Brite® should be reapplied as necessary for continued protection and will help to prolong the time between regular polishing.

UNLACQUERED BRASS AND COPPER

Items purchased in unlacquered brass and copper finishes will change with time as they develop a natural patina. The original shine can be restored using Faucet Brite® or an appropriate polishing compound. If you desire additional protection, the use of Faucet Brite® will aid in cleaning and protecting the surface finish from mineral deposits present in your water supply. Faucet Brite® should be reapplied as necessary for continued protection.

CORIAN®

Soapy water, ammonia based cleaners or commercially available solid surface cleaners will remove most dirt and residue from Corian® surfaces. Stubborn residue will require a slightly stronger cleaner. Follow the recommendations at www.corian.com to properly clean your vanity top or sink.

WOOD SURFACES

All wood furniture surfaces should be maintained with a soft, damp cloth. Paste wax can be applied to the furniture every six months. Commercial or residential use citrus-based sprays are not recommended for cleaning the furniture.

W A T E R W O R K S

Warranty

RESIDENTIAL LIFETIME MECHANICAL WARRANTY

Waterworks warrants to the initial purchaser or initial homeowner all plumbing* and accessory** products sold by Waterworks, which are installed in a residence to be used in a residential application, to be free from manufacturing defects in materials and workmanship for as long as the purchaser continues to own and maintain the residence where the products are initially installed. Proof of purchase (original sales receipt) from the original consumer purchaser must accompany all warranty claims.

5 YEAR FINISH WARRANTY

Waterworks warrants to the initial purchaser or initial homeowner the finish of all plumbing* and accessory** products sold by Waterworks, which are installed in a residence to be used in a residential application, to be free from manufacturing defects in materials and workmanship for a period of five years from installation of the products. Products must be maintained and cleaned in accordance with the instructions provided to purchaser by Waterworks.

Waterworks must receive notice of any warranty claim within the five-year warranty period. Proof of purchase (original sales receipt) from the original consumer purchaser must accompany all warranty claims.

5 YEAR WOOD FURNITURE WARRANTY

Waterworks warrants to the initial purchaser or initial homeowner the finish of all wood furniture products sold by Waterworks, which are installed in a residence to be used in a residential application, to be free from manufacturing defects in materials and workmanship for a period of five years from installation of the products. Wood furniture will have natural variation in grain structure, color shade, and inherent characteristics such as streaks which are not considered defects. Waterworks must receive notice of any warranty claim within the five year warranty period. Proof of purchase (original sales receipt) from the original consumer purchaser must accompany all warranty claims.

1 YEAR ELECTRICAL TUB COMPONENTS, WATER CLOSET, VITREOUS CHINA AND CAST IRON WARRANTY

Waterworks warrants to the initial purchaser or initial homeowner electrical tub components, vitreous china, cast iron tubs and water closet internal components sold by Waterworks, which are installed in a residence to be used in a residential application, to be free from manufacturing defects in materials and workmanship for a period of 1 year from installation of the products. Gloss reduction, scratching, staining, alkaline etching of the finish over time due to use, cleaning practices or water or atmospheric conditions are not manufacturing defects but are considered normal wear and tear. Waterworks must receive notice of any warranty claim within the one-year warranty period. Proof of purchase (original sales receipt) from the original consumer purchaser must accompany all warranty claims.

REPAIR OR REPLACEMENT

If within the applicable warranty period the covered products shall be proved to the satisfaction of Waterworks to be defective, Waterworks will repair or replace such products, at its expense (provided that such repair or replacement shall not include installation costs). Waterworks' obligation shall be limited to such repair and replacement and shall be conditioned upon Waterworks' receiving notice of any alleged defect within the applicable warranty period. (Purchaser shall be responsible for all shipping charges for returned products.)

LIMITATIONS ON WARRANTY COVERAGE

The warranties set forth above shall be extended only to the initial purchaser or initial homeowner and do not apply to any purchaser where the products are used for commercial applications and usage. Furthermore, the warranties do not cover installation or any other labor charges and do not apply to:

- I. Products subject to normal wear and tear;
- II. Products which have been repaired, altered or modified in any way by purchaser or any person other than Waterworks or not using original Waterworks service parts, unless previously authorized in writing by Waterworks;
- III. Products which have not been installed, used, maintained or stored in accordance with the instructions provided to purchaser by Waterworks;
- IV. Products which have been used for purposes other than or in a manner contrary to their intended and normal use; products that have been used outdoors;
- V. Products which have been damaged as a result of misuse, negligence, freezing, accident or faulty installation or maintenance;
- VI. Products damaged by the effects of dirt, salt water air, hard water, lime scale, or abrasive or aggressive cleaners. If the normal life span of any product is shorter than the applicable warranty period, the warranty shall apply only during the period of such shorter life span;
- VII. Products damaged from exposure to extremes of high or low humidity and/or to rapid temperature change as well as variations in appearance which result from the normal expansion and contraction of wood as it responds to climatic changes in the home;
- VIII. Products installed that are not in compliance with local code requirements. Since local code requirements vary greatly, installation contractors and users of plumbing or fixture products should determine whether there are any code restrictions on the installation or use of a specified product;
- IX. Products sold "as is" and from store displays.

NATURE OF WARRANTY CLAIMS

For all warranty claims please call Waterworks Product Support at 800 927 2120, or write to Waterworks Product Support at 60 Backus Avenue, Danbury, CT 06810.

The warranties provided herein are conveyed only to the purchaser of products sold by Waterworks after January 1, 2006 and installed in a residential application. Except as specifically set forth above, Waterworks does not make any other warranty, express or implied, including without limitation, any implied warranty of merchantability or fitness for a particular purpose. In no event shall Waterworks be liable to any person or entity for any indirect, special, incidental or consequential damages or loss (including damages for loss of business, loss of profits, or the like), whether based on breach of contract, tort (including negligence), product liability or otherwise, even if it has been advised of the possibility of such damages. Waterworks' liability on any claim of any kind, including negligence, shall in no case exceed the contract price paid by the purchaser for the product claimed to be defective or unsuitable.

Waterworks is a registered trademark of Waterworks, Inc.

While Waterworks uses reasonable efforts to include accurate and up-to-date information and photographs in the catalog and on the website, Waterworks makes no warranties or representations as to the accuracy of this information and these photographs. Waterworks assumes no liability or responsibility for any errors or omissions in the content or photographs in the catalog or on the website.

* Examples of plumbing products: fittings including lavatory sets, shower valves, tub fillers, shower heads, hand showers, bidet fittings, kitchen mixers, tubs (excluding electrical components).

**Examples of accessory products: fixtures including washstands, mirrors, towel bars, shelves, robe hooks, paper holders, hardware/knobs, and furnishings.

W A T E R W O R K S



ESTB. 1978

WATERWORKS SERVICE PARTS

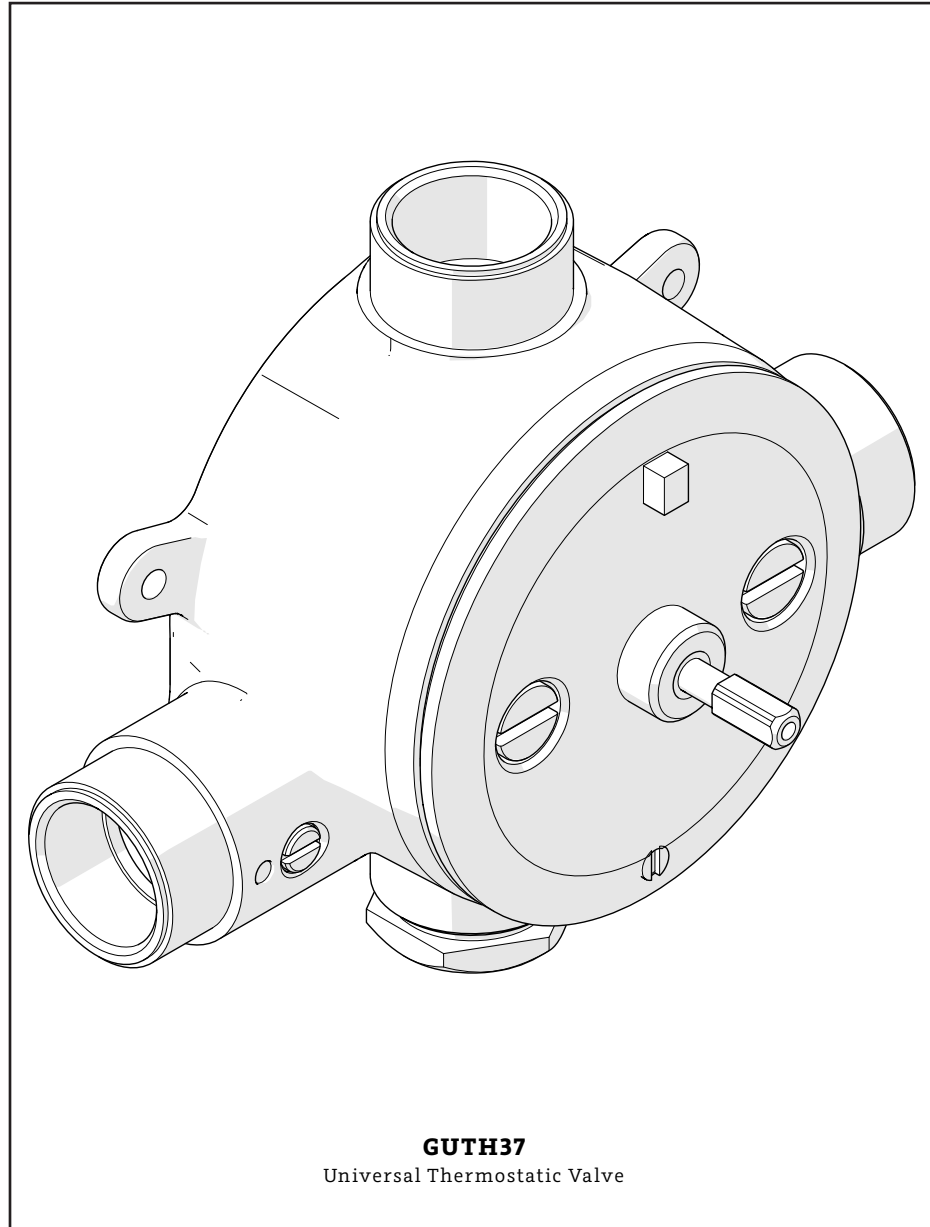

GUTH37
Universal Thermostatic Valve

WELCOME TO

WATERWORKS

For over three decades, Waterworks has transformed the bath through an absolute commitment to design authenticity, innovation and quality. A blend of scholarly appreciation and applied experience guarantees mechanical integrity, meticulous craftsmanship, and timeless designs.

**TO ORDER PARTS CALL
1 (800) 927-2120 (EXT 2)**

Order by part number and specify color, finish, or other options if required.

PRODUCT SUPPORT

Our Product Support team provides troubleshooting and technical problem resolution, including replacement parts and installation recommendations throughout the life of your product.

Product Support is available Monday through Friday, 8AM-6PM. EST.

**LIMITED LIFETIME
WARRANTY**

Our warranty covers repair and replacement of Waterworks products if within the applicable coverage period and deemed defective by Waterworks. Waterworks will, at its option, repair or replace such products; this does not include installation costs, labor charges, or other incidental or consequential costs.

To obtain your complete warranty or inquire about warranty service, please visit us at www.waterworks.com or contact our Product Support Team.



ESTB. 1978

WATERWORKS

MAIN KITS

STYLES: GUTH37

*FINISH/COLOR MUST BE SPECIFIED WHEN ORDERING
++SUPPLIED AS A PAIR

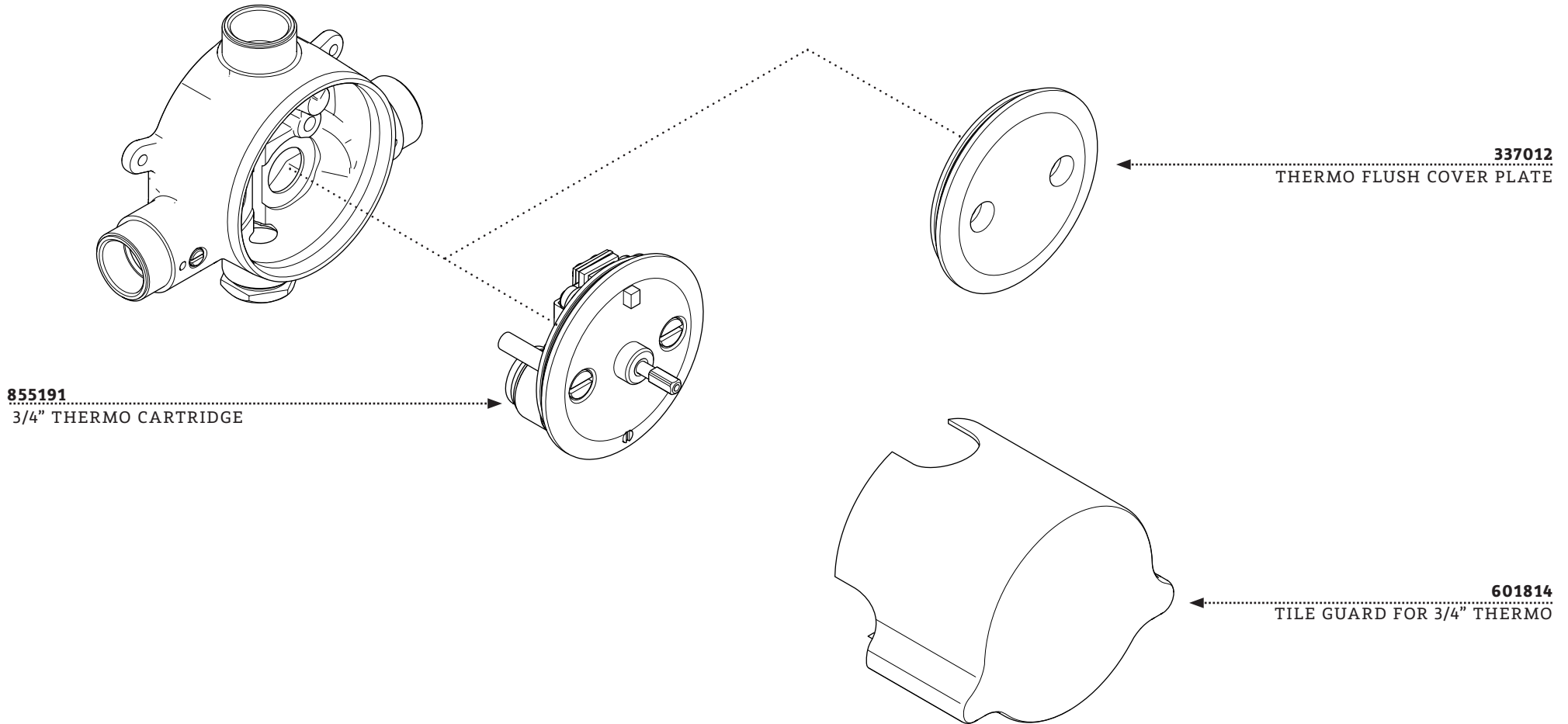



ESTB. 1978

WATERWORKS

KIT COMPONENTS

STYLES: GUTH37

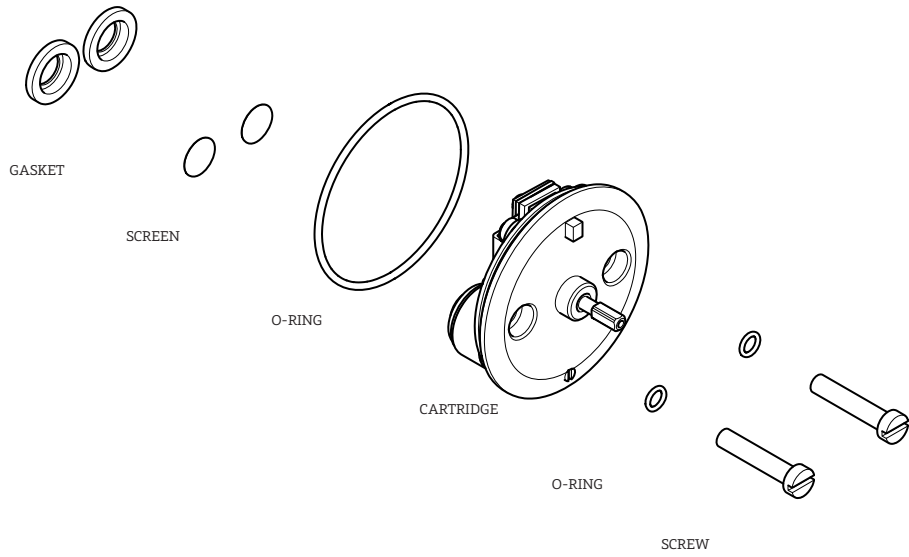
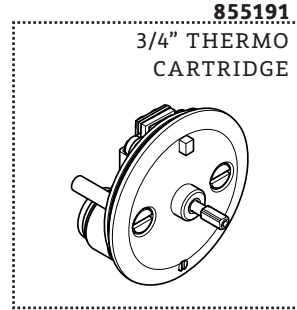

*FINISH/COLOR MUST BE SPECIFIED WHEN ORDERING
++SUPPLIED AS A PAIR

KIT COMPONENTS

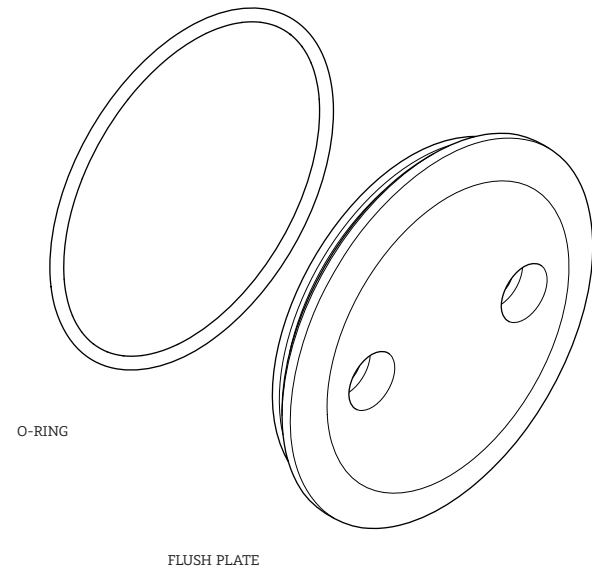
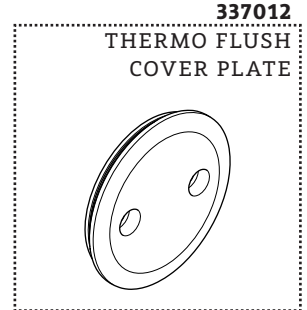



ESTB. 1978

W A T E R W O R K S

STYLES: GUTH37

SERVICE PARTS INDEX

<u>STYLE</u>	<u>DESCRIPTION</u>	<u>PG</u>
855191	3/4" THERMO CARTRIDGE	4
337012	THERMO FLUSH COVER PLATE	5
601814	TILE GUARD FOR 3/4" THERMO	3

*FINISH/COLOR MUST BE SPECIFIED WHEN ORDERING
++SUPPLIED AS A PAIR

NOTES

DOCUMENT: SPGU01_REV01



ESTB. 1978

WATERWORKS SERVICE PARTS

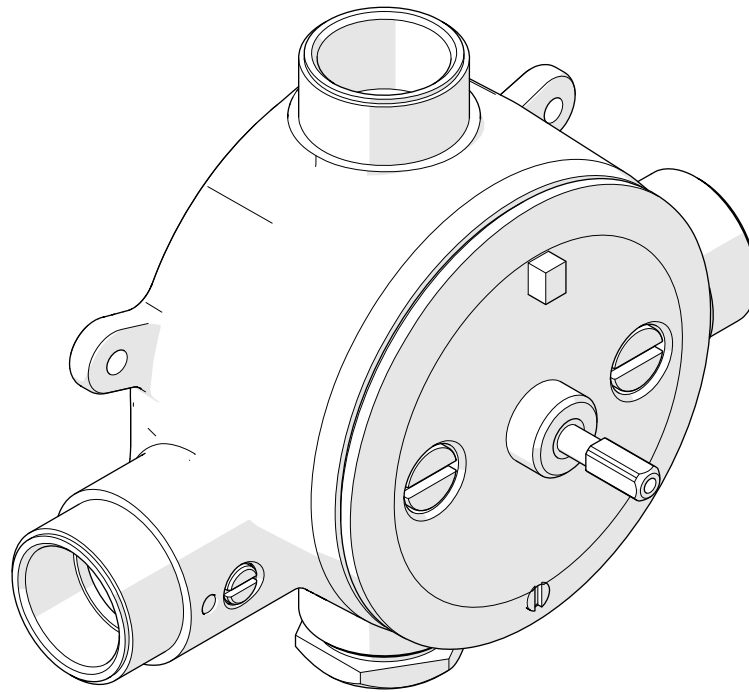

GUTH78

.25 Thermostatic Valve for .25 Thermo Shower Systems

WELCOME TO

WATERWORKS

For over three decades, Waterworks has transformed the bath through an absolute commitment to design authenticity, innovation and quality. A blend of scholarly appreciation and applied experience guarantees mechanical integrity, meticulous craftsmanship, and timeless designs.

**TO ORDER PARTS CALL
1 (800) 927-2120 (EXT 2)**

Order by part number and specify color, finish, or other options if required.

PRODUCT SUPPORT

Our Product Support team provides troubleshooting and technical problem resolution, including replacement parts and installation recommendations throughout the life of your product.

Product Support is available Monday through Friday, 8AM-6PM EST.

**LIMITED LIFETIME
WARRANTY**

Our warranty covers repair and replacement of Waterworks products if within the applicable coverage period and deemed defective by Waterworks. Waterworks will, at its option, repair or replace such products; this does not include installation costs, labor charges, or other incidental or consequential costs.

To obtain your complete warranty or inquire about warranty service, please visit us at www.waterworks.com or contact our Product Support Team.



ESTB. 1978

WATERWORKS

MAIN KITS

STYLES: GUTH78

*FINISH/COLOR MUST BE SPECIFIED WHEN ORDERING

++SUPPLIED AS A PAIR

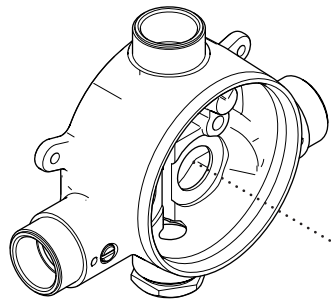

855191
3/4" THERMO CARTRIDGE

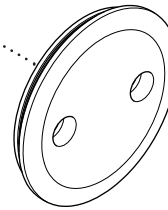
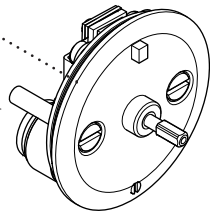

337012
THERMO FLUSH COVER PLATE

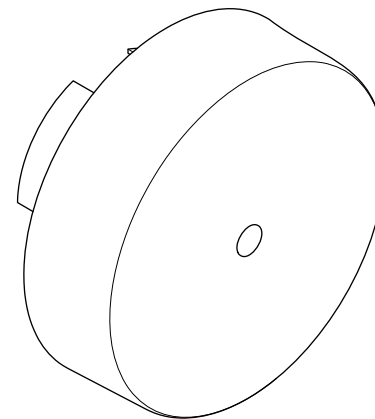

103665
6 5/8" TILE GUARD FOR
3/4" THERMO



ESTB. 1978

WATERWORKS

KIT COMPONENTS

STYLES: GUTH78

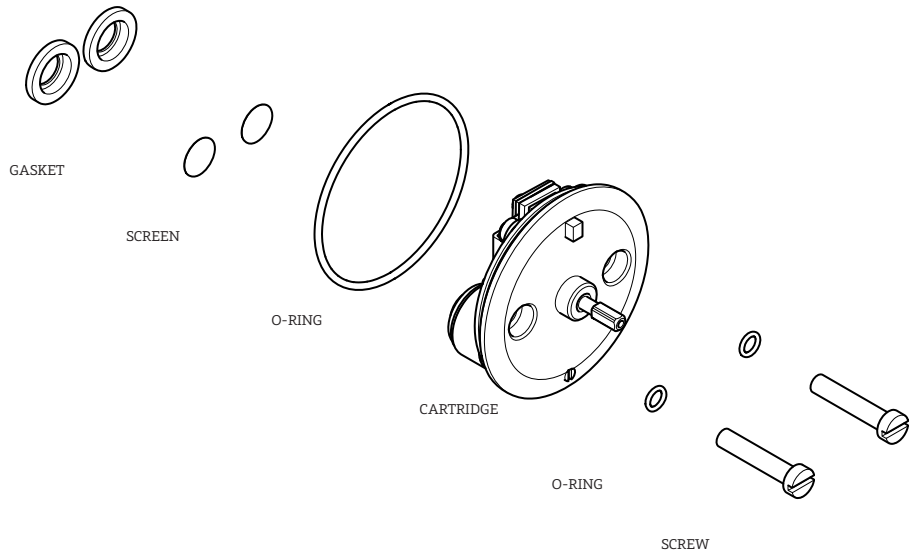
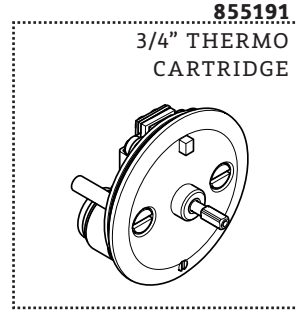

*FINISH/COLOR MUST BE SPECIFIED WHEN ORDERING
++SUPPLIED AS A PAIR

KIT COMPONENTS

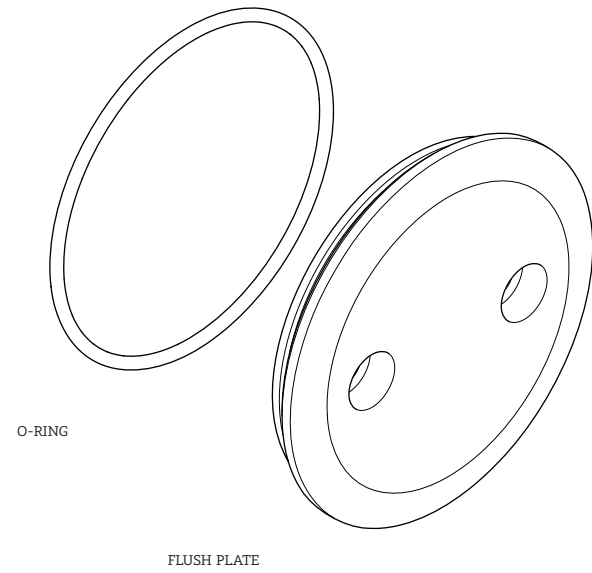
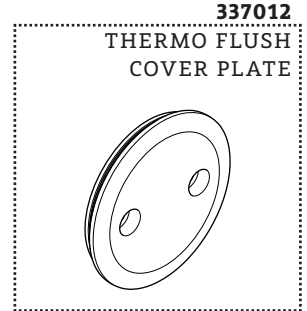



ESTB. 1978

WATERWORKS

SERVICE PARTS INDEX

<u>STYLE</u>	<u>DESCRIPTION</u>	<u>PG</u>
855191	3/4" THERMO CARTRIDGE	4
103665	6 5/8" TILE GUARD FOR 3/4" THERMO	3
337012	THERMO FLUSH COVER PLATE	5

STYLES: GUTH78

*FINISH/COLOR MUST BE SPECIFIED WHEN ORDERING
++SUPPLIED AS A PAIR

NOTES

DOCUMENT: SPGU04_REV01



ESTB. 1978

WATERWORKS

PRODUCT SUPPORT

60 BACKUS AVENUE
DANBURY, CT 06810

1 (800) 927-2120 (EXT 2)

WWW.WATERWORKS.COM