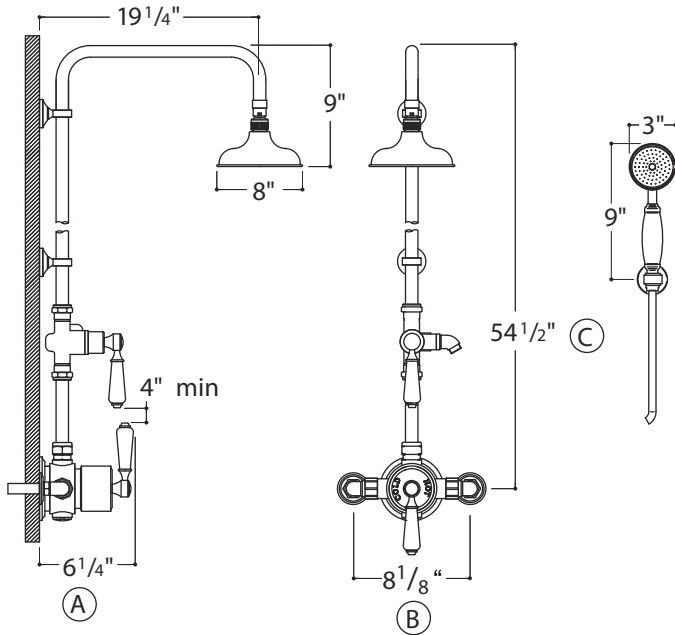

STYLE No. EAXS32

CODE No. EASV32-K
EASV33-K
EASV34-K
EASV35-K

STYLE No. EAHS32

CODE No. EAHS32-K - sold separately
EAHS33-K - sold separately
EAHS34-K - sold separately
EAHS35-K - sold separately

**SPECIFICATIONS:**

- Supply rough-in: 3/4" compression connection outside of wall.
- Figure A: suggested 4" clearance for comfortable lever operation.
- Figure B: proper lever position when not in use.
- Figure C: max. height with diverter is 54 1/2", 51" without.

IMPORTANT:

- To ensure this product is installed properly, you must read and follow these guidelines.
- The owner/user of this product must keep this information for future reference.
- The risk of scalding exists until the installer has properly calibrated the temperature setting.
- This product should be on-site prior to rough in and allows the installer to visualize the installation and verify the center spread. Determine if your installation will include a hand shower (sold separately) which must be considered for proper rough-in.
- This product must be installed by a professional licensed contractor. Be sure your installation conforms to all federal, state, and local codes.

- In the State of Massachusetts, all installations must comply with the rules and regulations set forth within 248 CMR.
- Inspect this product to assure you have all the parts required for proper installation.
- Refer to the specification and assembly drawings attached. Product is sold partially assembled but shown fully disassembled for illustrative and service purposes only.
- Check incoming water pressure; ideal operating pressure is 40-50 psi. The minimum is 25 psi. and the maximum is 85 psi.
- Use only a strap wrench or protected/smooth-jaw wrench on any finished surface.
- Install accessible hot and cold service stop valves to facilitate servicing.

ROUGH-IN:

1. Run well supported 3/4" hot and cold copper supply lines for maximum water flow. The spread between supplies is 8 1/8" on center and is NOT adjustable.
2. Determine the ideal location of the valve (11-18) based on user preference and taking into consideration ceiling clearance and proper shower head height. Install blocking to properly secure the valve body mounting plate (39,41), the 2 riser brackets and, if applicable, the hand shower (sold separately).
3. Verify the supplies are secure, level, at the proper spread of 8 1/8" and equal depths. Cap off the supplies and check for leaks.

VALVE INSTALLATION:

4. Cut each of the copper supplies so they extend 1" past the surface of the finished wall.
5. Turn on the water to flush out the supply lines.
6. Unthread and remove the compression nuts (34) and the compression rings (33) and then slide 1 onto each copper supply.
7. Thread the elbow (30) into the valve body (54) until it stops, then UNthread it enough so it will be aligned with the supplies. Note that the elbow seal is created by the o-ring (30) and NOT by fully tightening the elbow onto the inlet nut (28).

IMPORTANT:

Verify that a filter screen (32) is installed into the inlet side of each elbow (31). If screen fits loosely, remove and compress slightly to increase the outside diameter of the screen to create a snug fit.

8. Position the valve body assembly onto the supplies until they are fully seated in the elbow (31) and then hand tighten the compression nuts (34). If there is a gap between the surface of the finished wall and the valve mounting plate (41), cut the supplies.

These guidelines have been prepared for the professional contractor to aid in the installation of:
EASTON CLASSIC EXPOSED THERMOSTATIC SYSTEM WITH 8" SHOWER ROSE (STYLE No. EAXS32) &
EASTON HANDSHOWER WITH DIVERTER (STYLE No. EAHS32).
All dimensions are based on original specification and are subject to change and variation.
Please consult your Design Associate for current specifications.

WATERWORKS

9. With the valve mounting plate against the wall, mark its location so the plate can be secured.
10. Loosen the compression nuts and pull the valve body assembly off of the supplies.
11. Loosen the 2.5 mm hex screw (39) on the valve mounting plate (41).
12. Hold the plate against the wall in its proper location based on the marks made in step 9 while making sure the screw holes are located at 9 and 3 o'clock and then make a mark for each of the 2 holes.
13. Drill 2 holes at the proper location and secure the mounting plate to the wall using the mounting hardware (40,42) provided.
14. Align the valve body with the supplies and mounting plate and then attach the valve body assembly to the mounting plate by tightening the 2.5 mm hex screw (39).
15. Complete final connections by tightening the compression nuts (34).

IF A HAND SHOWER WILL BE INSTALLED, CONTINUE WITH STEP 16; IF NOT, CONTINUE WITH STEPS 18-21:

16. With the hand shower hose connection pointing to the right, determine the proper position of the diverter. For comfortable operation of the levers (3,20d), there should be a minimum 4" gap between the diverter handle positioned at 6 o'clock and the valve handle positioned at 12 o'clock as shown in the illustration.
17. Cut a piece off of the riser to make the connection between the valve and diverter. Make sure this piece is long enough to be inserted deep enough into the valve and diverter to assure a tight connection. Install the diverter.
18. Determine the ideal height of the riser and proper location of the 2 riser supports as shown in the drawing. The riser can be cut as needed.
19. Remove the 1.5mm set screw from each riser support and then secure the riser mounting plates to the wall using the hardware provided.
20. Lightly lubricate the o-ring inside each riser support, slide the supports onto the riser, then insert the riser into the valve body or diverter body as applicable.
21. Secure the riser supports to the riser mounting plates and then tighten ALL connections. If a hand shower is NOT being used, continue with "Calibrate the Temperature".
22. Thread the check valve housing (23h) onto the diverter elbow (8d) making sure a 1/2" washer (22h) is installed at the connection. Make sure the check valve is inside the housing.
23. Using a 2mm hex wrench (17ah), loosen the 2mm set

screw (17h) and remove the mounting plate (12h) from the hand shower hook (14-18h).

24. Determine the ideal location of the hook and then drill 2 holes to accommodate the mounting hardware provided.
25. Position the mounting plate (12h) with the flat side facing the wall and then secure it using the 2 anchors (11h) and screws (13h) provided.
26. Position the hook against the mounting plate while making sure the 2mm set screw is located at 6 o'clock as shown and then tighten the set screw. The opening of the hook MUST face to the left so the tapered end of the hose fits properly.
27. Thread the knurled end of the hose (25h) onto the check valve housing and then thread the conical end onto the hand shower (1-9h) making sure a 1/2" washer (10h,24h) is included at both connection points.
28. Rotational adjustment of the hook can be made by removing the hook and turning the 5mm hex bolt (14h) on the back side of the hook.

CALIBRATE THE TEMPERATURE:

- The risk of scalding exists until the installer has properly calibrated the temperature setting.
29. Unthread the handle assembly (1-6) from the handle base (11) and then insert a screw driver tip into the hole on the side of the handle base and pop off the handle cap (7,8). Remove the handle screw (9).
 30. Fully open the valve to HOT by rotating the handle base counter clockwise. When rotated counter clockwise, the valve sequence is: OFF-COLD-HOT.
 31. With the valve all the way open, set the upper temperature limit by inserting a 2.5mm hex wrench into the valve stem (20) and rotate it counter clockwise to increase the temperature and clockwise to decrease the temperature.
 32. Turn the valve off and then on again to verify the temperature range; adjust as needed.
 33. Reinstall the handle while making sure the o-ring (10) is included.

COMPLETE FINAL INSPECTION:

34. Install the showerhead onto the riser. Note there is a 2.5gpm flow restrictor in the swivel.
 35. If desired, a bead of caulk or silicone may be applied where the escutcheons contact the wall.
 36. Operate the valve and make sure the diverter is operating properly.
- If further assistance is required, please contact Product Support at 1-800-927-2120 (8am-6pm EST).

These guidelines have been prepared for the professional contractor to aid in the installation of:
EASTON CLASSIC EXPOSED THERMOSTATIC SYSTEM WITH 8" SHOWER ROSE (STYLE No. EAXS32) &
EASTON HANDSHOWER WITH DIVERTER (STYLE No. EAHS32)
 All dimensions are based on original specification and are subject to change and variation.
 Please consult your Design Associate for current specifications.

W A T E R W O R K S

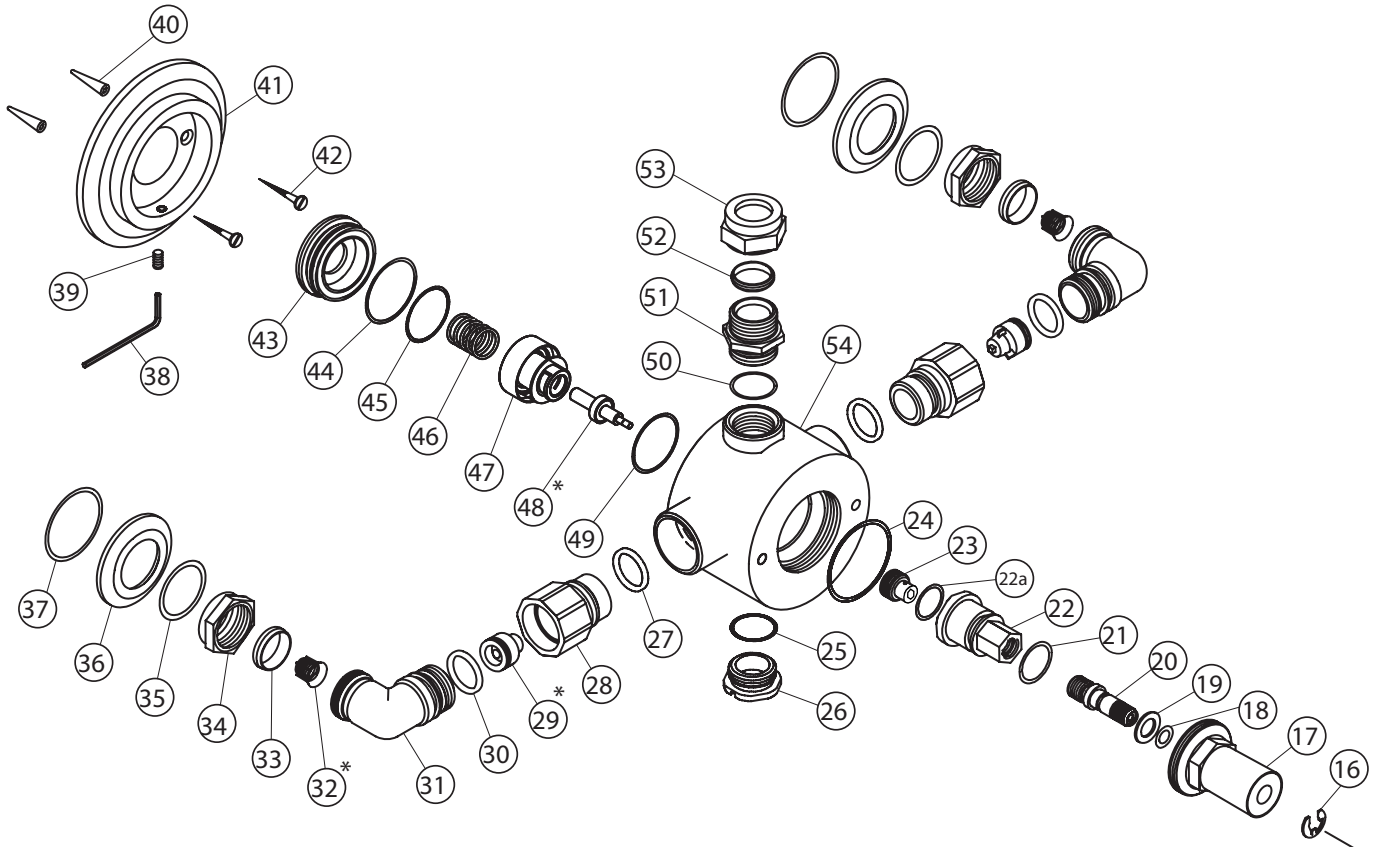

- (39)*, (14)* 2mm hex
- (29)* Check valve
- (32)* Filter
- (48)* Thermostat

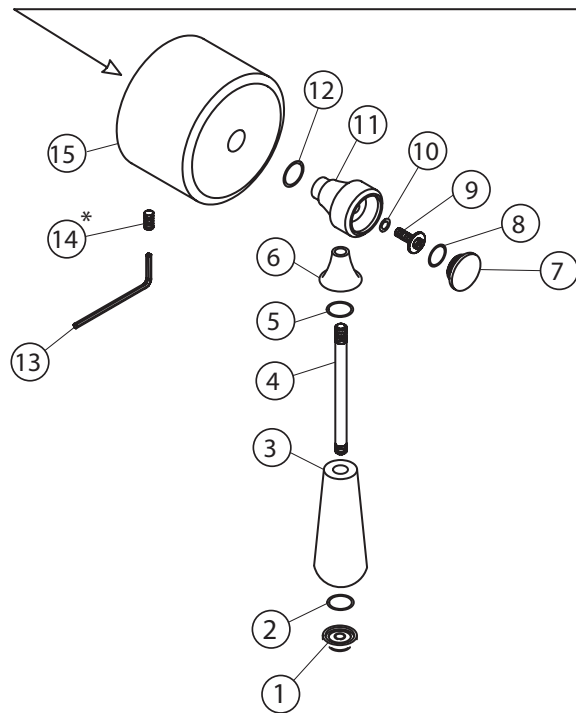

These guidelines have been prepared for the professional contractor to aid in the installation of:
EASTON CLASSIC EXPOSED THERMOSTATIC SYSTEM WITH 8" SHOWER ROSE (STYLE No. EAXS32) &
EASTON HANDSHOWER WITH DIVERTER (STYLE No. EAH32).
 All dimensions are based on original specification and are subject to change and variation.
 Please consult your Design Associate for current specifications.

WATERWORKS

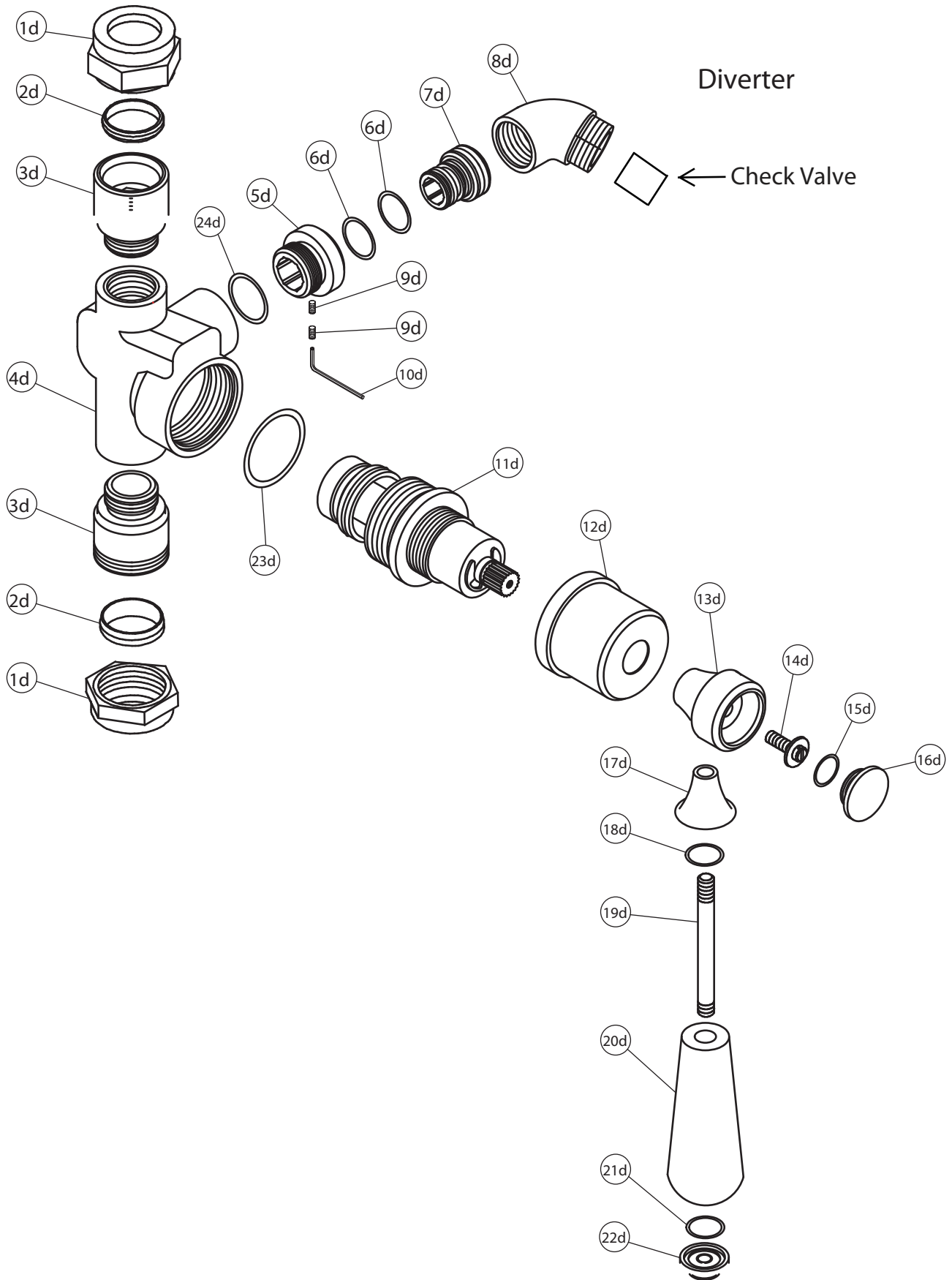

These guidelines have been prepared for the professional contractor to aid in the installation of:
EASTON CLASSIC EXPOSED THERMOSTATIC SYSTEM WITH 8" SHOWER ROSE (STYLE No. EAXS32) &
EASTON HANDSHOWER WITH DIVERTER (STYLE No. EAHS32).
 All dimensions are based on original specification and are subject to change and variation.
 Please consult your Design Associate for current specifications.

WATERWORKS

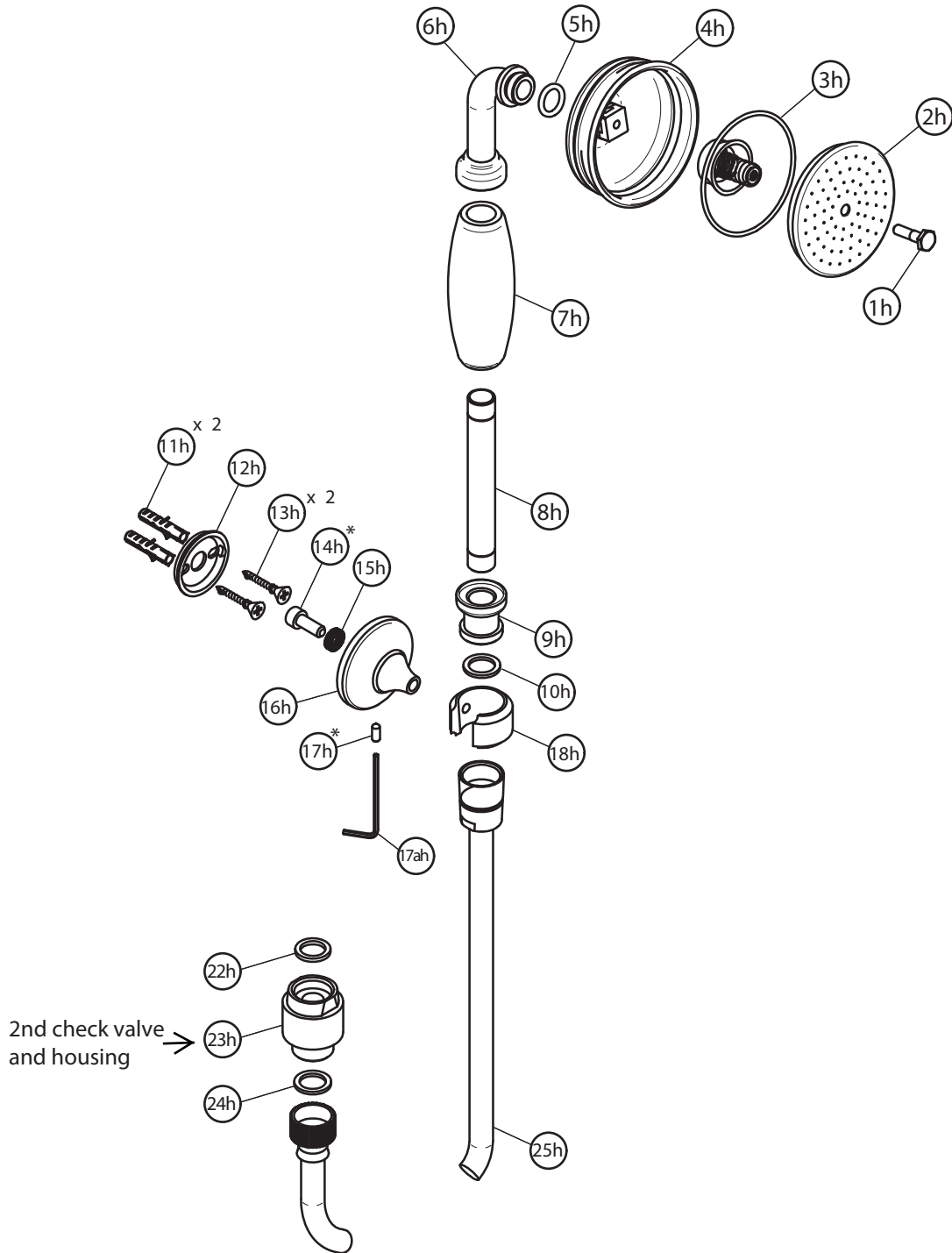

- ⑭* : 5 mm hex
- ⑰* : 2 mm hex

These guidelines have been prepared for the professional contractor to aid in the installation of:
EASTON CLASSIC EXPOSED THERMOSTATIC SYSTEM WITH 8" SHOWER ROSE (STYLE No. EAXS32) &
EASTON HANDSHOWER WITH DIVERTER (STYLE No. EAHS32).
 All dimensions are based on original specification and are subject to change and variation.
 Please consult your Design Associate for current specifications.

WATERWORKS